



ULTIMHEAT

HEAT & CONTROLS



FLOW THROUGH LIQUID HEATERS FOR INCORPORATION

- Immersion heaters:
- Air heating solutions:







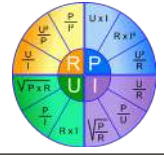

See catalogue No.22

See catalogue No.24

Contact us



Because of permanent improvement of our products, drawings, descriptions, features used on these data sheets are for guidance only and can be modified without prior advice

Section 1	Summary	Page Cat23-2-1-1~2	P1-P2		
Section 2		Historical introduction	Page Cat23-2-2-1~8	P1-P8	
			Technical introduction	Page Cat23-2-2-9~11	P9-P11
			Heaters size selection chart vs power	Page Cat23-2-2-12~82	P12-P82
Section 3	List of references	Page Cat23-2-3-1~4	P1-P4		
Standard liquids heaters			P1-P26		
Section 4		9SU107	Heaters dia. 70mm, length 70mm Max 1 × 3kW (20W/cm ²) 1 × 1.5kW (10W/cm ²)	P3	
		9SU113	Heaters dia. 70mm, length 130mm Max 1 × 3kW (10W/cm ²) 1 × 1.5kW (5W/cm ²)	P4	
		9SU231	Heaters dia. 76mm, length 313mm Max 3 × 2.5kW (10W/cm ²) 3 × 1.25kW (5W/cm ²)	P5-P6	
		9SUB31	Heaters dia. 76mm, length 313mm, coiled tubular heaters Max 3 × 3.2kW (10W/cm ²) 3 × 1.6kW (5W/cm ²)	P7-P8	
		9SU331	Heaters dia 80mm, length 313mm Max 3 × 2.5kW (10W/cm ²) 1.25kW (5W/cm ²)	P9-P10	
		9SUC31	Heaters dia. 80mm, length 313mm, coiled tubular heaters Max 3 × 3.4kW (10W/cm ²) 3 × 1.7kW (5W/cm ²)	P11-P12	
		9SU431	Heaters dia 88mm, length 313mm Max 3 × 2.5kW (10W/cm ²) 3 × 1.25kW (5W/cm ²)	P13-P14	
		9SUD31	Heaters dia. 88mm, length 313mm, coiled heaters. Max 3 × 3.8kW (10W/cm ²) 3 × 1.9kW (5W/cm ²)	P15-P16	

Summary







Section 4		9SU531	Heaters dia. 125mm, length 313mm. Max 3 × 3kW (10W/cm ²), 3 × 1.5kW (5W/cm ²).	P17-P18
		9SUE31	Heaters dia. 100mm, length 313mm, coiled heaters Max 3 × 4.3kW (10W/cm ²) 3 × 2.15kW (5W/cm ²)	P19-P20
		9SU631	Heaters dia 125mm, length 313mm. Max 3 × 4kW+3 × 2kW (10W/cm ²), 3 × 2kW+3 × 1kW (5W/cm ²)	P21-P22
		9SU731	Heaters dia 125mm, length 313mm. Max 3 × 4kW+3 × 2kW (10W/cm ²), 3 × 2kW+3 × 1kW (5W/cm ²)	P23-P24
		9SU831	Heaters dia 140mm, length 313mm, with tubular heat exchanger. Max 3 × 3kW (10W/cm ²), 3 × 1.5kW (5W/cm ²)	P25-P26

Options and accessories

Page Cat23-2-5-1~16

P1-P16

Section 5		Options of temperature control and temperature safety Prewired disc thermostats Prewired TCO Manual reset bulb and capillary thermostats	P3-P7
		Flow detection Flow switches Flow switches add-on kits	P8-P12
		Hydraulic safety options Manual and automatic air bleeders (air vents) Relief valves	P13
		Tanks options Legs and hose clamps Heating element wires Foam insulation jackets Coated foam insulation jackets	P14-P15

 : These products are not made by Ultimheat

Update 2025/03/20



Historical introduction



Because of permanent improvement of our products, drawings, descriptions, features used on these data sheets are for guidance only and can be modified without prior advice



Circulation and storage water heaters.

In 62 AD, Seneca, in his book “Natural Questions” (quaestiones Naturales), Book III, describes the water circulation water heaters in Roma at this time as follows:

“We are in the habit of constructing serpentines, and cylinders, and vessels of several other designs in which thin copper pipes are laid in descending spiral coils. The object is to make the water meet the same fire over and over again, and flow through a space sufficient for heating it up; so, entering as cold it comes out hot.”

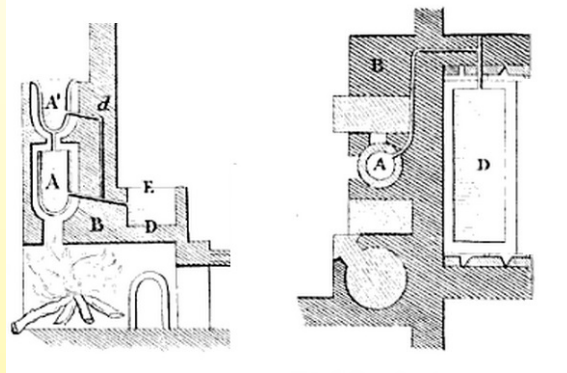

Bathroom heaters with tanks for accumulating warm water and having inlet pipes of cold water and hot water outlet were known and used in Italy at Roman time.

Above: Section of a hot bath of a Roman villa in Pompeii, using the principle thermosiphon with two reservoirs A and A' supplying water to the tub D by the tube d. (Voyage pittoresque ou Description des royaumes de Naples et de Sicile, par l'abbé de Saint-Non (1781), vol 2).

The Roman architect Vitruvius in the first century AD describes similar circulating water heaters. Although translated and commented again by the Italian architect Palladio in 1556, in his work on Vitruvius, this system disappeared with the Roman civilization. It was not until 1777 that the French engineer Jean Simon Bonnemain reuses the thermosyphon and perfects it for the use of heating by means of circulating water in a boiler and pipes. It was first used to heat plants in the “Jardin du Roi” in Paris, then to heat a large poultry hatchery near Nanterre with a precise temperature control. This concept for circulating the water in radiators, by means of the density difference between the hot and cold water still remained virtually unknown for nearly 40 years. The Marquis de Chabannes, French emigrant to England, copied the Bonnemain's work, and improved this system in 1815 to heat apartments with what will later named the hot water central heating. Reimported in France in 1831, it became popular during the second half of the 19th century.

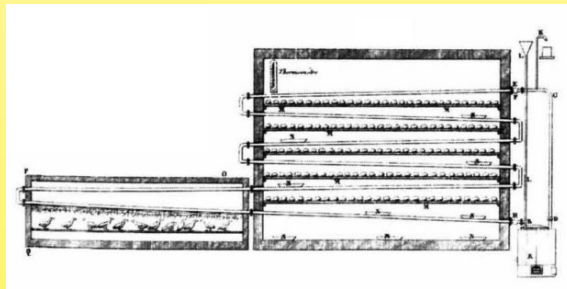

1777 Hatchery heating by boiler and thermosyphon, by Jean Simon Bonnemain (Ultimheat Museum document)

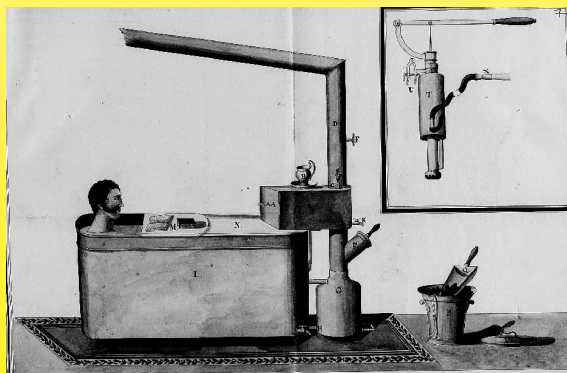

1820: Bath tub heating was also one of the centers of interest of researchers at the time. M. Bizet, of Paris, invented a tub heated by thermosyphon (INPI Patent), very close to what the Romans were using. Coal, which was becoming more widely used in Paris, is used to heat the boiler.

1896: Mr. Morineau in Paris, develops an instantaneous water heater with a coiled tube exchanger, gas fired, similar to models already on the market under the name “capillary tub heaters”, but for the first time it had an automatic valve detecting the passage of the water to turn on and turn off the burner.

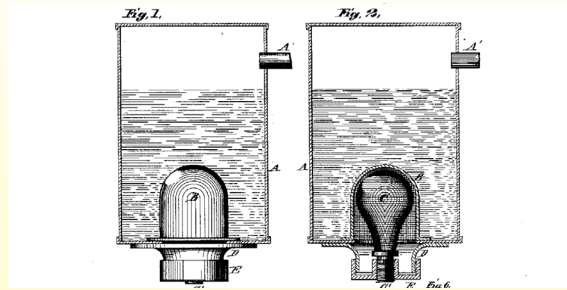

1889, Daniel Smith, from St Louis (Missouri, USA), files a patent for an electric storage water heater, whose heating is provided by a platinum wire inside a glass bulb, under a protection dome. (US patent 411737). Although this patent remained unexploited, it can be considered as the ancestor of electrical water heaters.

Between 1890 and 1900, the development of electric power flourished inventions that tried to use it as a means of heating for water and houses. Hundreds of patent were filed in a few years, most of them in the US, which were the pioneers of domestic electrical power distribution. But in Europe this energy was then very expensive, and electrical distribution was patchy and limited to lighting needs. Wood, coal, gas and kerosene remained long time the only water heating means. The precursors in Europe between 1890 and 1892 were Crompton (England), Friedrich Wilhelm Schindler Jenny (Switzerland), and Henriot and Lebrasseur (France). Electrical water heating appliances were, at that time, limited to kettles

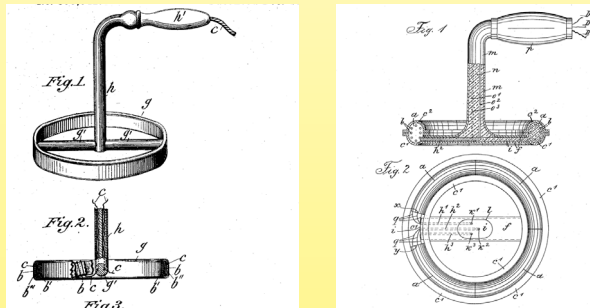

1891, The Swiss citizen Friedrich Wilhelm Schindler-Jenny, resident in Kennelbach (Austria-Hungary), makes the first immersion heaters, for warming water tanks (Austro-Hungarian Patent No. 37527 and No. 13680 of August 22, 1891). These patents will be extended in Switzerland, Belgium, France, Italy, England and the USA.

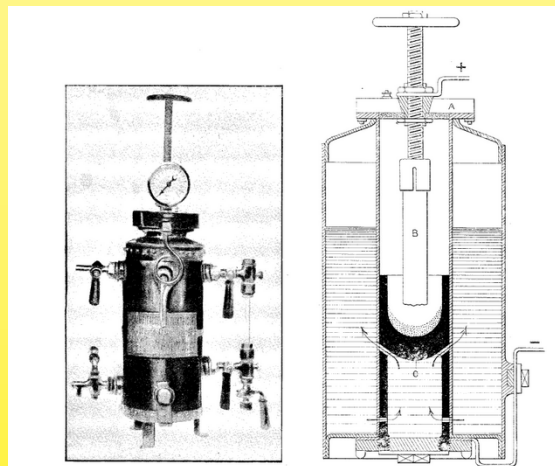

1900. The first electric boiler seems to have been that of the Russian engineer Ougrimoff, which was presented at the Universal Exhibition. He called this device “Calorifacteur électrique”. It worked by creating an electric arc between two electrodes, and was particularly used to produce steam. In 1923, the Swiss company Oerlikon started to manufacture similar electric boilers, named electrode heating boilers, under the name Revel. This technical solution to produce steam and hot water is still manufactured by some companies, mainly for high power boilers.

The mansions of the early 20th century generally produce hot water via a cast iron heat exchanger called “bouilleur” (boiler) located in the foyer of the stove. By thermosyphon, his boiler feeds a large water tank located higher, thermally insulated, ancestor of our storage water heaters and foreshadowing the current systems called REC (Renewable Energy). This system was common in almost all stoves manufacturers catalogues throughout the first half of the century. Similar exchangers were installed on central heating boilers with hot water production.



Because of permanent improvement of our products, drawings, descriptions, features used on these data sheets are for guidance only and can be modified without prior advice

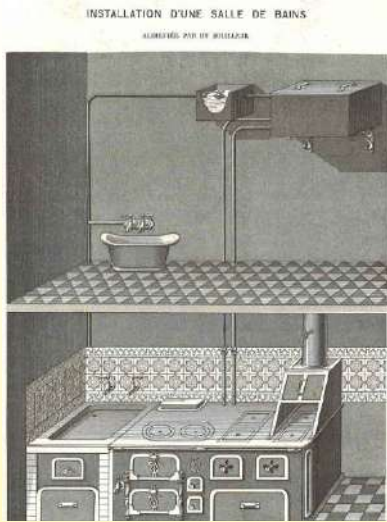

1894 Bathroom with hot water supplied by a stove with "Bouilleur" (Chappée Catalog, Ultimheat Museum)

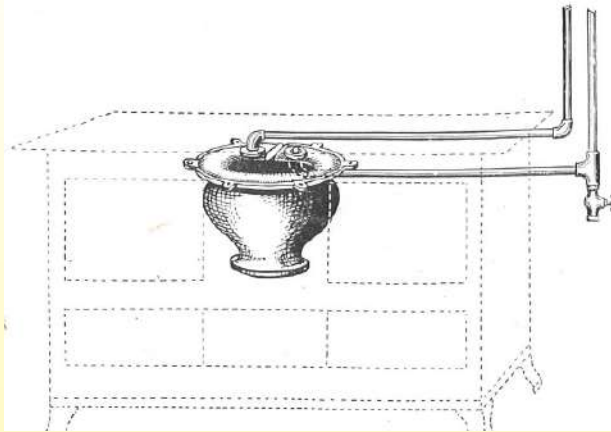

Heat exchanger "Bouilleur" mounted inside a stove (Catalog of Ets Demoulin, Farciennes, 1932, Ultimheat Museum)

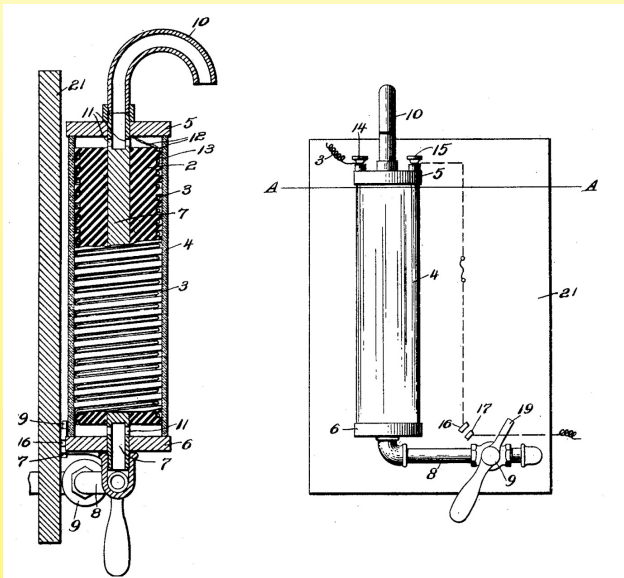

February 1905, the American citizen Eli Sager apply for a patent for an instantaneous electrical water heater

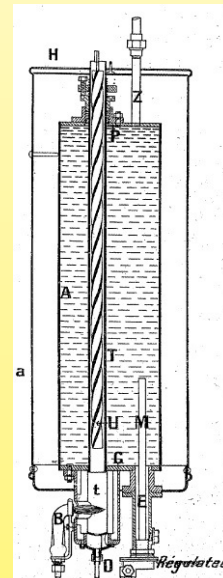

In 1913 Ets Grouvelle and Arquembourg in Paris developed the first storage gas water heater equipped with a temperature controller. "The Marseillais"

1915 While the rest of Europe is at war, Switzerland that produces cheap electricity by means of hydroelectric dams, sees the rise of the first electric storage water heaters, they are described by the magazine of Civil Engineering (22 May 1915)

"The use of electricity, as heat for cooking, tends to spread wherever the electricity can be produced fairly cheap ... M. Ringwald, director of power plants of Central Switzerland in Lucerne, has made to the General Assembly of the "Swiss Society for the use of waterfalls", a very interesting conference on the use of electricity for cooking and heating ... The Company that manages the speaker serves several locations where are used a lot of electrical cooking appliances, so that it was possible, therefore, to make serious statements ... A device based on the principle the accumulation of the heat is the hot water tank, which is largely in favor of the public, particularly one with a capacity of 15-30 liters. The apparatus consists of a thick plate cylinder, surrounded by a heating resistor easy to replace; everything is wrapped in insulation.

The device is connected to a water line; at night, the water heats up, the power is expended 160 to 200 watts. An automatic switch reduces the power consumed to 50 or 70 watts, which is sufficient to compensate for losses, when the water has reached a temperature of 80 to 90 degrees. This unit can be connected to any pipe light.

As the unit works mostly at night, electricity is counted at a very low price (5 cents per kilowatt hour), it uses the same counter as the light, and it records only determined fraction of the energy used for heating water.

It was found that over 24 hours, these devices consume, for 16 to 18 hours, the maximum power "

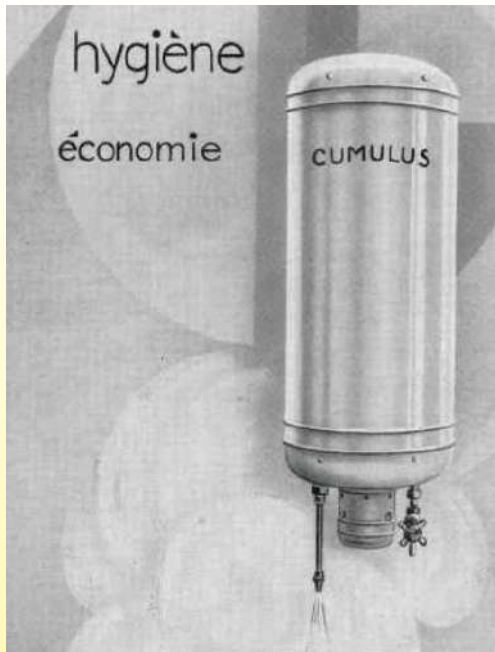

In 1917 thanks to the opportunities of the Swiss market described above, a Swiss engineer, Fritz Sauter, who developed in 1910 an automatic switch electric appliance system to use the night rate, invented an electric storage water heater named “Cumulus”, whose name has been later coined into French language for electrical storage water heaters. It started to be sold in France in 1922, when Sauter set up its French factory in Saint Louis. The tanks are then thermally insulated with cork granules.

In 1928, Sauter claimed to have sold more than 15000 of them worldwide. (Ultimheat Museum document).

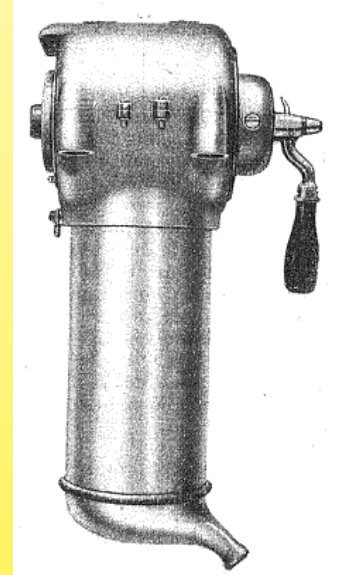
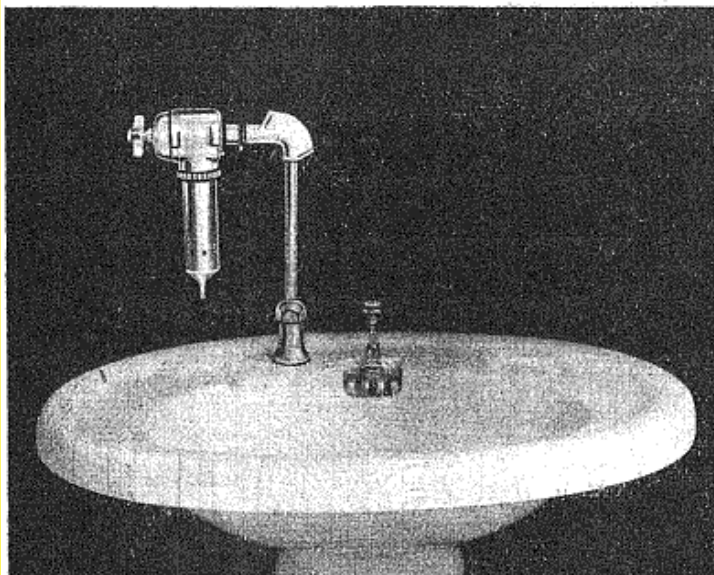

1922, the company Presto, Paris, develops a faucet mounted instantaneous water heater in which water is heated by its own conductivity, without heating wires. This technical solution, had the default is to be very sensitive to the quality of water, is still used to produce steam on machines to take off the wallpaper and similar equipment. (Ultimheat museum documents)

From 1925, electricity is increasingly available in homes, and as it becomes less expensive, storage water heaters and electric tub heaters proliferate. Manufacturers like Lemercier and Etelec-Electroculmul start their productions. Many others will follow.



Because of permanent improvement of our products, drawings, descriptions, features used on these data sheets are for guidance only and can be modified without prior advice

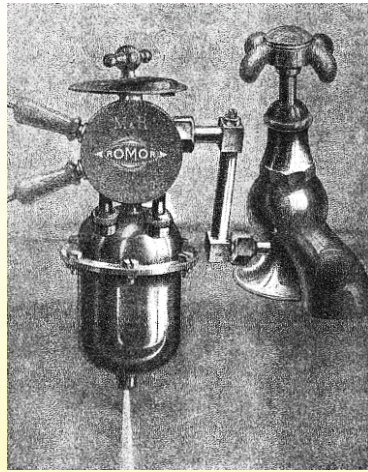

1924. The electric instantaneous water heaters mounted on the faucet are expanding, The mark "Romor" manufactured by Moersch and Roumet in Paris, has some success with them. The company Tubulec will also manufacture them until the 1950s (Ultimheat Museum documents).

1928, In the east of France, electricity companies set up special discounted electricity price during the night. Therefore, accumulation water heater producers will install there factories overwhelmingly in this part of France.

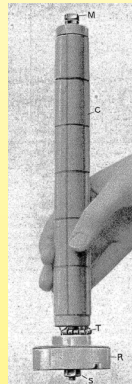
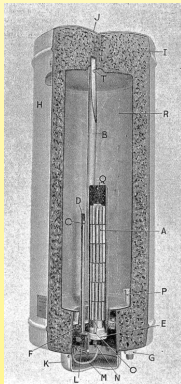

1928 "Electro-cumul" electric water heater made since 1925 by Etelec, Etablissement électromécaniques de Strasbourg. The heater is single tube type, with ceramic barrel on which are coiled heating wires. Water is heated at 95°C. (Ultimheat Museum)

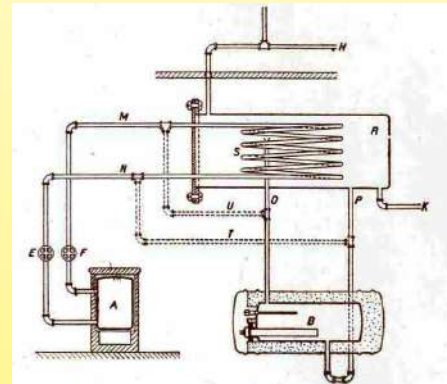

1927 Coal-electric dual-energy water heating, Etelec, with tubular heat exchanger inside a storage tank. (Ultimheat Museum)

**CHAUFFE-EAU ÉLECTRIQUES
A ACCUMULATION
ÉLECTRO-CUMUL-ALS-THOM
DE 25 A 300 LITRES**

Les appareils "ELECTRO-CUMUL-ALS-THOM" sont réputés pour le soin apporté à leur construction, la qualité de leurs réservoirs, leur aspect élégant, le fini de leur peinture et surtout pour leur rendement élevé.

Ces chauffe-eau laissent à nos clients la plus grande latitude dans le choix de l'équipement. Ils sont, en effet, munis d'une "bride universelle" qui peut recevoir la plupart des thermostats couramment employés; ceux-ci sont catalogués à part.

Les corps de chauffe sont normalement du type "à gaine" et peuvent être changés sans vider le réservoir, mais, sur demande, nous livrons une bride spéciale, interchangeable, recevant les corps de chauffe "Calrod". (Demander les conditions spéciales.)

1936. The sheathed tubular heaters, recently invented in the USA (Calrod-General Electric) and Sweden (Baker) arrive on the market; Als-thom uses them on its Electro-cumul storage water heaters. (Ultimheat Museum document).

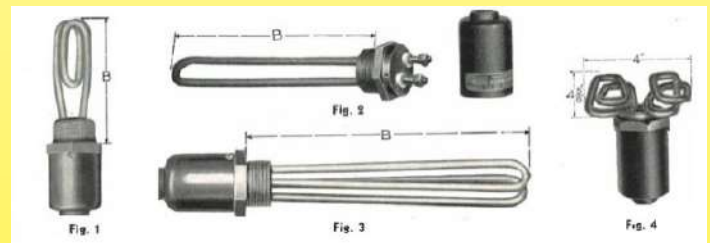

1932 Calrod sheathed tubular heaters (Ultimheat museum document)

The reservoirs of hot water storage or circulation heaters are then made of copper for small volume or galvanized steel for large models. In these, leakages due to corrosion are common, especially at the welds, as the galvanic corrosion is not yet well mastered

1935: One begins to consider heat pumps heating with hot water storage, produced at the night low cost electricity: "The principle of the heat pump, very seductive in itself, seems not about to be used routinely. It leads to expensive machinery, usually non-silent and of a delicate maintenance. It requests bulky bodies, such as the heat exchanger and the evaporator, and will allow the exclusive use of off-peak hours power with the hot water heater and with a prohibitive accumulator volume due to the low temperature of the water used. Its practical use in the current state of the art seems difficult" (Bulletin de la société industrielle de l'Est, July 1935)



Because of permanent improvement of our products, drawings, descriptions, features used on these data sheets are for guidance only and can be modified without prior advice

Technical introduction



Because of permanent improvement of our products, drawings, descriptions, features used on these data sheets are for guidance only and can be modified without prior advice



Design rules of our heaters: Quality, efficiency, adaptability, durability.

A liquid heater is not only an assembly of a tank and sheathed tubular heaters. To produce an effective, safe and reliable product, all components must be developed together for the application, and best technical solutions chosen. To achieve the best technical and economic results, we study and produce ourselves tanks, heaters, and most of the other components.

Our original design and innovative construction of our heaters, the first that were developed specifically for the heat pumps and renewable energies market, their technicality, their quality and durability level have been awarded worldwide by leading manufacturers of heating appliances.

All raw materials, all the construction details, all assembly operations were designed to offer the best product at the best cost. The reasons of our technical choices are detailed in this document.

From it, according to your specifications, and thanks to our experience, our design department will review the product most suited to your application, with the best price-quality ratio.

Then, to validate your product, our laboratory with over 200 testing machines, can make all the tests we describe hereunder. The products in this catalog are designed to be incorporated in heating equipment and appliances, are intended only to OEM, professional users, consultants and engineering departments, knowing and aware of the local technical and safety standards they have to comply with.

The purpose of this technical introduction is to help engineering departments to make a reasonable choice among all the technical solutions that we propose.

Note: This technical introduction is provided for general guidance only. Relevance and completeness of technical data and / or information should be analyzed carefully by the manufacturer. It's up to him verify the suitability of our product in the final application for which it is installed.

On request, we provide prototypes for this purpose.

Examples and references displayed in this catalog are given for guidance, and many variations are possible for OEM applications.



Summary of technical introduction

A	A - Heating elements design rules	14~25
A1	Sheathed tubular heater or steatite heaters inside tubular sheath	14
A2	Main metals used in sheathed tubular heaters.	15
A3	Sheathed tubular heaters bending radius limits	16
A4	Minimum possible bending diameter (mm), for bending at 180°, tube axis to axis, without need to repress (Average values).	17
A5	Watt density selection parameters.	17
A6	Liquides flow velocity	17
A7	Normal working conditions, with circulating flow.	18
A8	Surface temperature in abnormal working conditions, without liquid flow.	18
A9	Non-heating zone, also said cold zone.	19
A10	Insulation resistance and leakage current.	19
A11	Tubular heaters moisture porosity.	19
A12	End seals solutions against water vapor porosity in tubular heaters.	20
A13	Insulation resistance testing vs temperature on tubular heaters end seals only. (Made on 10mm OD tubes with dia. 4mm connection rod)	21
A14	Measurement of insulation resistance, leakage current.	21
A15	Note on insulation resistance measurements.	21
A16	Magnesium oxide thickness vs insulation value and water vapor recovery	22
A17	Effect of temperature on the insulation resistance of compacted magnesium oxide	22
A18	Insulation distances of sheathed tubular heaters	23
A19	Pollution degrees	25
B	B - Tanks body design rules	26~30
B1	Reasons for use of 1.2mm stainless steel.	26
B2	Welding interstices	26
B3	Water hammer	27
B4	Pressure resistance upon flanges design.	28
B5	Leaks testing.	29
B6	Inlet and outlet pipe sizing upon pressure drop and flow rate.	29
B7	Tanks and heaters installation position and dead zones.	30
B8	Examples of wrong design or wrong installation.	30
B9	Examples of efficient design and installation.	30
C	C - Tanks water inlet and outlets	31~34
C1	Fitting threads use for main inlet and outlet and for auxiliary circuits	31
C2	Hydraulic connection examples.	31
C3	Usual threads dimensions	32
C4	Threaded connections solutions.	32
C5	Water circuit inlet and outlet main positions.	33
D	D - Tubular heaters mounting on tanks	35~38
D1	Heaters mounting solutions on tanks	35
D2	Joining of heating elements on the circulation heater tank	36
D3	Maintaining the heating elements tubes.	37
D4	Distance between heating elements and tank or tube metal walls.	38
E	E - Thermowells (Pockets) and TCO installation	39~45
E1	Pockets design	39
E2	Comparison of raw materials that can be used in heaters thermowells	39
E3	The 3 solutions to close tube end and related pressure resistance.	40
E4	Thermal response time vs thermowell design, normal use.	41
E5	Thermal cut-out mounting solutions.	41
E6	Dry run condition, thermal cut out response time vs thermowell distance with tubular heater, for 5W/cm ² and 10W/cm ² .	42
E7	Results of dry run tests made on heaters with and without thermal fuse.	44
F	F - Surface mounting thermostats	46~50
F1	Surface mounting thermostat mounting solutions.	46
F2	Disc thermostat sealing solutions.	47
F3	Thermal response time when liquid temperature is rising, upon thermostat surface mounting solutions	48
F4	Thermal response time in dry run conditions upon thermostat surface mounting solution.	49
G	G - Heaters wall mounting solutions.	51~52
G1	Studs or bolts mounting	51
G2	Legs mounting	51
G3	Precise positioning solution for accessories brackets.	52

Technical introduction



Because of permanent improvement of our products, drawings, descriptions, features used on these data sheets are for guidance only and can be modified without prior advice

H	H: Wiring rules.	53~62
H1	Terminals protection after end sealing.	53
H2	Terminals temperature rise vs protection and power	54
H3	Heating elements configurations upon the operating voltage.	54
H4	Main wiring diagrams.	55
H5	Mounting possibilities of heating elements depending on the size of the tank and the supply voltage.	56
H6	General comparison of wires and cables.	56
H7	Insulation materials tensile strength (Considered as an indicator of the sensitivity to accidental cut of insulation layer)	56
H8	Wires pull strength vs potting material and wire insulation material.	57
H9	Comparison of insulation thickness (average values in mm)	57
H10	Comparison of wires and cables used in products internal wiring	58
H11	Relative price comparison to H07-VK (1.5mm ² wires*)	59
H12	Zero halogen and flame retardant cables and wires insulation.	60
H13	Temperature rise of an electrical wire vs electrical intensity and ambient temperature.	61
H14	Earthing rules requested by standards.	61
H15	Earthing terminals of heaters.	62
H16	Cover for mechanical protection of wiring	62
I	I - Control and safety devices	63~65
I1	Electronic temperature controllers, thermostats, temperature limiters, thermal cut outs.	63
I2	Temperature sensors.	64
I3	Flow switches.	65
J	J - Thermal insulation	66~68
J1	Thermal insulation Foams	66
J2	Comparison of main technical specs of both foams.	66
J3	Surface protection of thermal insulation foams.	67
J4	Testing reports of insulation foams critical features in heaters applications.	67
K	K - Protection against scaling	69~70
K1	Anti-Scaling design rules.	69
K2	Scaling deposit vs temperature.	70
L	L - Protection against corrosion	71~79
L1	Design rules against metal corrosion.	71
L2	Intergranular corrosion.	72
L3	Contamination by iron oxides during the process.	73
L4	Corrosion by Chlorine and Chlorides.	73
L5	Recommended stainless steel grades vs free chlorine and chloride percentage.	73
L6	Design rules against galvanic corrosion, also called Bimetallic Corrosion.	74
L7	Some special cases of bimetallic electrochemical couples uncluding stainless steel	75
L8	Electrochemical couples of various metals	76
L9	Corrosion under insulation.	76
L10	Corrosion aggravating factors.	77
L11	Summary of the rules implemented during the heaters manufacturing operations to prevent the occurrence of corrosion.	78
L12	Protection by sacrificial magnesium anodes	79
L13	Protection by imposed current electrode	79
M	M - Formula and Technical charts	80~84
M1	Ohm's law.	80
M2	Table of the power in watts of an electrical heater versus resistance and voltage across terminals.	80
M3	Single phase heating elements wiring.	81
M4	3 Phase heating elements connections.	81
M5	Calculation of the power needed to heat liquids.	82
M6	Temperature rise of water in °C per hour/volume/power.(Theoretical calculation, thermal losses not deducted)	82
M7	Comparison of temperature rise in °C/hour in some liquids and solid	83
M8	Specific heat (cp, in kJ/kg°C) and specific gravity (ρ, in Kg/m ³) of main liquids.	83
M9	Specific heat (cp, in kJ/kg°C) and specific gravity (ρ, in Kg/m ³) of main solids.	84
M10	Water flow for usual liquid heaters.	84

A - Heating elements design rules

A - 1 Comparison of sheathed tubular heaters and ceramic heaters inside sheathing tubes

In water heaters, and especially in storage water heaters, two solutions exist primarily to heat water: Sheathed tubular heaters and ceramic heating elements inside sheathing tubes.

Sheathing tube is usually an enamel coated metal tube, but sometimes it is made in stainless steel.

In storage water heaters, the average surface watt density of the sheathing tubes with ceramic heaters is 5W/cm² to meet the “Class C, NFC Performance” standard, which requests less than 6W/cm². So, this value of 5W/cm² will be used as a comparative value.

Steatites resistors are available in many diameters like 32, 36, 47 or 52mm. But 52mm diameter but is most used.

For their incorporation inside liquid heaters, the primary requirement is dimension.

Usual dimensions of ceramic heaters used inside sheathing tubes

Power (W)	Ceramic barrel diameter (mm)	Length (mm)
2000	52	320
2500	52	350
3000	52	450
3600	52	500

Advantages and disadvantages of the two solutions

Drawing	Type	Advantage	Disadvantage
	Tube with dia. 52mm ceramic barrel heater	<ul style="list-style-type: none"> - Low cost when the tube and the flange are made in enameled steel as the body of the tank. (Storage water heaters) - No moisture absorption. - Replaceable without need to drain the tank. 	<ul style="list-style-type: none"> - Risk of corrosion requesting an anode protection (Enameled versions) - Limited to low watt density (<5W/ cm²). - Important footprint prohibiting the installation in small diameter or short length tanks. - Very big size three-phase versions. - Long response time due to poor heat transfer between the heater and the tube wall. - High cost and very long response time with stainless steel sheath.
	Sheathed tubular heaters	<ul style="list-style-type: none"> - Small footprint - Numerous bending variants allowing adaptation to all heaters volumes - Fast response time, well suited for circulating liquid temperature control - Low cost when welded directly onto the walls. - Made of stainless steel or corrosion resistant alloys. - High watt densities are possible, depending on the application, up to 20W/cm². <p>This is the solution chosen for the heaters of this catalog</p>	<ul style="list-style-type: none"> - Moisture recovery (If poor quality manufacturing)



A - 2 Main stainless steels used in liquid heaters.

There are many different possible sheath materials for tubular heaters used for heating liquids. Many stainless steel grades may be used. In addition to the economic side, the choice must consider the conditions of use, the liquid heated and the requested service life. However, the most important factors are the nature of the liquid to be in direct contact with the heating element, and temperature.

EN	AISI	DIN	Use
EN 1.4301	AISI 304	W. 1.4301	In water or humid environment max. 450°C. In line heaters tanks are commonly made out of 304. It is the less costly of the materials mentioned in this list
EN 1.4307	AISI 304L	W. 1.4307	Same than 304 for humid-corrosive environments. Used for washing machine heating elements and heaters tanks. Better corrosion resistance after TIG welding than 304.
EN 1.4541	AISI 321	W. 1.4541	In water or humid environment max. 550°C. Washing and cooking heating elements. This alloys is similar to 304L, but with Titanium added to decrease the carbide precipitation. To be a true "stabilized" grade the 321 steel has to have Titanium (Ti) content at least 5 times of Carbon's (C). Not used in heaters tanks.
EN 1.4404	AISI 316L	W. 1.4404	Improved resistance to corrosion. For water or corrosive humid environment max. 450°C. Used in circulation heaters heating elements for central heating circuits. Used in heater tanks walls when a superior corrosion resistance is requested, usually when chlorides are used for water disinfection.
EN 1.4435	AISI 316SL	W. 1.4435	Equivalent to 316L, with the difference that the higher content of molybdenum ensures elevated mechanical features and resistance to corrosion. In water or corrosive humid environment max. 500°C. Very little use.
EN 1.4571	AISI 316Ti	W. 1.4571	Equivalent to AISI 321, with the addition of molybdenum besides titanium. For temperatures of 500°C, also in discontinuous service. Very little use.
EN 1.4876	Alloy 800	W. 1.4876	Also Referred to as Incoloy 800. In water and air with max. temperature up to 1050°C. Corrosion resistance similar to AISI316L in central heating circuits. Not used for circulation heaters tanks.
EN 2.4858	Alloy 825	W. 2.4858	Also Referred to as Incoloy 825. In water or highly corrosive environments. Same applications than alloy 800 but superior corrosion resistance at elevated temperatures.
EN 1.4847	Alloy 840	W. 1.4847	Also Referred to as Incoloy 840. In air for max. temperature up to 950°C. Not used in liquid heating.
Ti II	UNS R50400	W.3.7035	This material is used extensively in immersion heating, sea water piping, reactor vessels. Withstand highly corrosive materials. It is the most costly of the sheath materials mentioned in this list

A - 3 Sheathed tubular heaters bending radius limits

The search for compactness and therefore the raw material cost reduction used in making tanks faces a critical technical requirement which is the minimum bending radius of the heating elements. It is this parameter, in addition to the heating tube length required depending on the power and the selected load density which decide the size of the tank.

In all applications where the supply voltage can be greater than 230V, the tubular heaters with a dia. less than 8mm are not usable because the insulation distances are not sufficient to meet the safety standards requirements.

That is why we are developing heaters with heating elements dia. 8 or 10mm diameter and not 6.5mm

The elements can be bent in various ways, in single or double hairpins, in flattened rings, and helical. Each of these bending methods has its advantages and disadvantages. To go below the minimum bending radius is possible through technical tricks, but its result often reduces the life of heater, increases the rate of field failures or causes high scrap rates in manufacturing, and therefore increases the production cost.

Single airpin	Double airpin	Helical airpin	Helically coiled

Bending radius limits are given by three parameters:

1/ The sheath tube raw material elongation limit:

This parameter depends of the annealed raw material elongation value. The tube will crack if this value is exceeded. To prevent such failures, if the bending diameter is under the minimum limit, the bending must be made in 2 or more steps, with a new annealing between each step.

2/ The magnesium oxide sieves and compaction value:

In the process of bending, hairline cracks can develop in the compacted magnesium oxide in the bends. The larger is the tube diameter, the bigger is the risk that this happens. These cracks can lead to overheating and coil failure, especially at high temperatures or high watt densities.

To prevent such failures, if the bending diameter is under the minimum limit, the bends must be re-pressed to eliminate cracks in the magnesium oxide



A - 4 Minimum possible bending diameter (mm), for bending at 180°, tube axis to axis, without need to repress (Average values)

Tube diameter	304 / 304L	316 / 316L	321	Incolloy 800	Incolloy 825	Titanium (ASTM grade 1)
6.5	22	22	22	26	28	35
8	26	26	26	30	33	41
10	30	30	30	35	38	47
12	36	36	36	42	46	57
16	48	48	48	56	61	75

A - 5 Watt density selection parameters

Figures provided in this section are results of tests made in our laboratory. Charts were smoothed by computer, and are given for specified power and for information only.

General rules.

It is recommended to select a surface load which does not produce local boiling of the liquid at the surface of the heating element. This phenomenon, called cavitation, causes rapid wear of the protective sheath of the heating element, decomposition or chemical transformation of the liquid, and the deposit of limestone and contaminants (carbonates, chlorides etc..). In the case of drinking water, these deposition processes are amplified when the water temperature reached 65°C, and for water hardness exceeding 10dH.

Recommendations for the choice of specific watt densities were given in 1966 in DIN 44875 (last version: 1986-09) "Electrical Metal Sheathed Tubular Heating Elements; Use"

They are basic and simply give as maximum values for stainless steel elements 12 W/cm² in still water, and 25W/cm² in pouring water.

Some storage water heater standards recommend a watt density less than 6W/cm², especially Class C of the French standard "NFC Performance".

These watt density levels are easily attainable in sheathed tubular heaters and the rumor that steatites heaters inside pockets are more efficient and produce less limestone is due solely to their comparison with 10 or 12W/cm² sheathed tubular heaters.

To facilitate understanding in usual application configurations, we carried out the following tests by measuring in several places the surface temperature of the heating elements by miniature thermocouple spot welded to its surface. Consult factory if in doubt about the proper watt-density for the heater in a particular application.

A - 6 Liquids flow velocity

Sheathed heaters surface temperature in in line circulation heaters versus water velocity and surface power

In applications with permanent flow, the important parameter is the velocity of the liquid around the heating element. In the graphs below, the speed is given in meters per minute.

The temperature data from these curves is the difference between the surface temperature of the heating element and the fluid temperature, measured 50mm above the heating element. The tests were performed with pure water, and water with glycol addition of 25% and 50%, for surface loads from 1 to 20 W/cm². The heating elements are completely submerged.

In central heating circuits the recommended minimum water velocity is 18m/min (0.3m/s), but they refer to water velocity in the piping. In heaters, because, the water velocity is reduced proportionally to the section surface ratio.

Water velocity (m/min) inside heaters upon water flow

Heater OD (mm)	2 L/min	5 L/min	10 L/min	20 L/min	50 L/min	100 L/min	250 L/min	500 L/min
70	0,56	1,4	2,8	5,6	14	28	70	139
76	0,47	1,2	2,4	4,7	12	24	59	118
80	0,42	1,1	2,1	4,2	11	21	53	106
88	0,35	0,87	1,7	3,5	8,7	17	43	87
100	0,27	0,67	1,3	2,7	6,7	13	33	67
125	0,17	0,42	0,85	1,7	4,2	8,5	21	42
140	0,13	0,34	0,67	1,3	3,4	6,7	17	34



A - 7 Normal working conditions, fully immersed tubular heaters, circulating liquid

Heating elements fully immersed, pure water	Flow, immersed, 25% glycol	Flow, immersed, 50% glycol
<p>In pure water, in all cases of this test, the <u>boiling temperature is not reached</u> when the water is at less than 40°C when it comes into contact with the heating elements. However, for an inlet temperature of 40°C the temperature of 65°C is reached in all cases with a load of 8W/cm² and more</p>	<p>In water with 25% glycol, commonly used in heating circuits, the <u>boiling temperature is reached</u> at speeds of less than 6 m/min from 8W/cm² with a water inlet temperature of 40°C. All loads greater than 8W/cm² reach the boiling point.</p>	<p>In water with 50% glycol, used in heating circuits which have to withstand very low temperature, <u>the boiling temperature is reached</u> for speeds less than 8 m/min and loads of 5W/cm² with an inlet temperature water of 40°C. All loads greater than 5W/cm² reach the boiling point.</p>

A - 8 Abnormal working conditions, without liquid flow

Heating elements surface temperature evolution in time, when flow is stopped, versus heating element surface load

The tests were performed with pure water, 25%, and 50% glycol added water, as they are representative of liquids used in central heating and solar heating circuits, and with peanut oil representative of liquids used in food applications.

<p>At no flow condition, values of temperature difference 50mm top and 50mm bottom of heating element.</p> <p>It is possible to see huge temperature difference, mainly in oil.</p> <p>Note: On the water test with 10W/cm² load, after 6 minutes, the water around the heating element starts boiling, and the temperature differences decreases progressively, because of the convection provided in the water by ebullition.</p>	<p>At no flow condition, difference between heating element surface temperature and liquid temperature measured 50mm above the heating element, at various surface loads. Heating element is fully immersed. (Measurements made 10 minutes after energization)</p> <p>Note: Above 8W/cm², there is no increase of temperature difference in water and water + glycol, because liquid in contact with heating element starts to boil and energy is used for vaporization.</p>	<p>At no flow condition, this is a simulation of what happens when the heating element starts to rise from the liquid level. (Half immersed tubular heater, measurement made after 10 minutes). Heating element surface temperature rises sharply.</p> <p>Note: For oil, the flash point (320°C) is reached at 7W/cm² load, and auto-ignition may occur (Fire hazard)</p>

Because of permanent improvement of our products, drawings, descriptions, features used on these data sheets are for guidance only and can be modified without prior advice



A - 9 Non-heating zone, also said cold zone

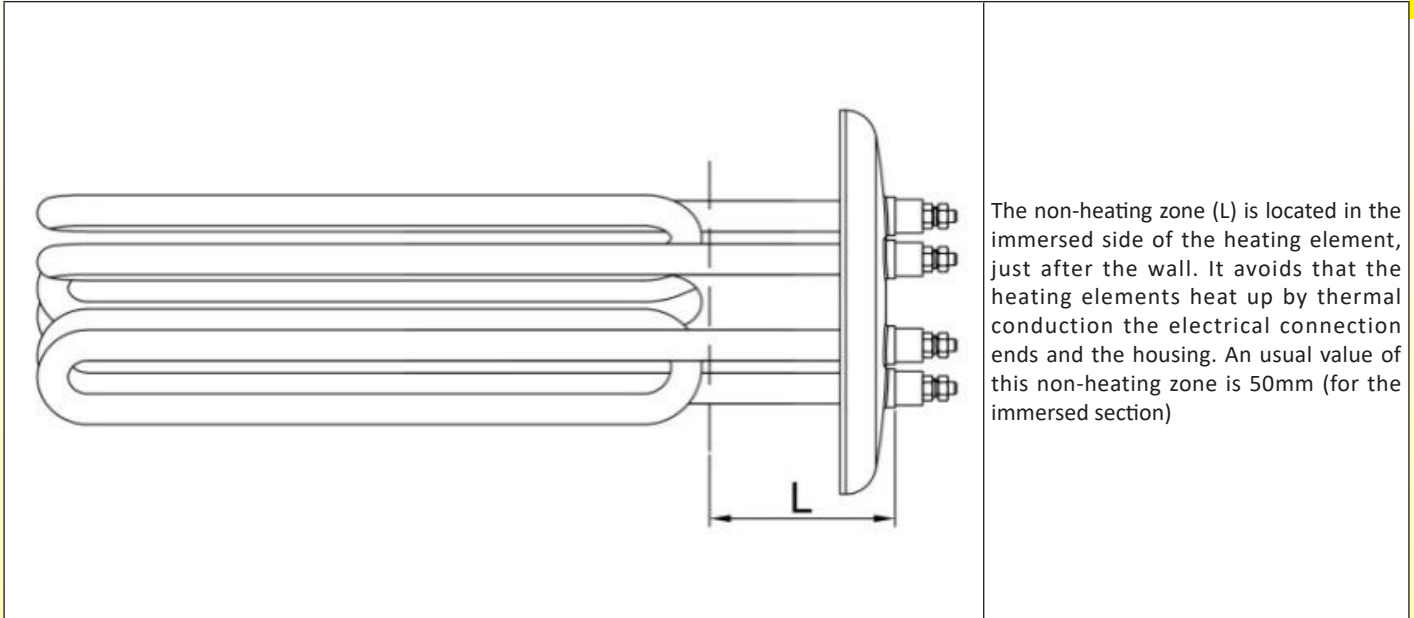

The non-heating zone (L) is located in the immersed side of the heating element, just after the wall. It avoids that the heating elements heat up by thermal conduction the electrical connection ends and the housing. An usual value of this non-heating zone is 50mm (for the immersed section)

A - 10 Insulation resistance and leakage current

From DIN44874-1, -2, -3 standards, first published in 1966 on sheathed tubular heaters, resulted the basic specifications of most European manufacturers such as tolerances +5 / -10% on the power, leakage current less than 0.5mA in 1250VAC, and insulation resistance greater than 2Mohms in 500V, heater at cold position.

These values, although still currently used in EN60335-1 Annex 1 standards, are however inadequate in many applications because they do not take in account the moisture absorption phenomena in time.

In in-line heaters, the insulation resistance must reach much higher values and construction quality must provide a more secure retention of insulation in time.

We take great care to ensure the maximum level of performance to this electrical insulation.

The end results are the combination of multiple factors, from the excellent centering of heating wires coils, the right technical choice of tubes end sealing, including the quality of magnesia used.

A - 11 Tubular heaters moisture porosity.

This critical point is that on which the heaters manufacturers provide the less information because it is the one that poses the **greatest technical difficulties.**

Magnesium oxide (MgO or magnesia), used for insulation of the sheathed tubular heaters, is highly hydrophilic and rapidly absorbs ambient atmospheric moisture. The moisture absorption significantly reduced its insulating properties and leakage current can happen to trigger GFCIs.

Unless you are using a magnesia made less hydrophilic by coating the grains with silicone oil (called hydrophobic magnesia), which greatly reduces the temperature at which it can operate, the solutions to prevent moisture absorption lie in the design of the tube ends closure, to reduce or eliminate the passage of atmospheric water vapor.

It is traditional for tubular heaters manufacturers to say that is normal and that one just need to warm the heaters to eliminate the internal moisture, which is only a temporary stopgap, and can even lead to a moisture recovery even bigger and faster if the armored elements were sealed with low temperature resins.

Some manufacturers even consider an armored resistance insulation value of 5 or 20 Megohms as standard, and recommend to warm them up between 150°C and 260°C (300to 500°F) overnight if their insulation value drops below 1 Megohms (50% below the minimum value of the 1966 safety standard!). **This is a great disregard to users safety, although in these conditions (leakage current of 23mA 230V), the home GFCI always trigger.**

See below the comparison with the insulation values and moisture absorption rate of our heaters.

Because of permanent improvement of our products, drawings, descriptions, features used on these data sheets are for guidance only and can be modified without prior advice



A - 12 End seals solutions against water vapor porosity in tubular heaters

Type	Features	Advantages	Disadvantages
Silicone resins	Silicone resins are widely used for the end sealing of heating elements, because of their excellent temperature resistance.	<ul style="list-style-type: none"> - Excellent temperature resistance (up to 230°C), - No change in their electrical insulation characteristics versus temperature. - They do not break - Good bonding to the heater tube wall 	<ul style="list-style-type: none"> - Silicone resins are porous, with a moisture vapor transmission rate (MVTR), up to 100gr*mm/m²/day at 23°C and 90%RH
Epoxy resin	<p>Epoxy resins, less used, have to be selected with great care, because of their widely varying characteristics according to the qualities and suppliers. The temperature they can withstand, their glass transition point, their flexibility, and curing conditions are critical parameters.</p> <p>The Glass Transition Temperature (T_g), one of the most important properties of epoxy is the temperature region where the polymer transitions from a hard, glassy material to a soft, rubbery material and change phase. In this temperature range, its volume resistivity drops, strength and hermeticity are also greatly reduced</p>	<ul style="list-style-type: none"> - Low moisture vapor permeability rate (MVTR), 6 to 10g*mm/(m²*24h) at 90% relative humidity. - Good bonding on stainless steel 	<ul style="list-style-type: none"> - Low temperature resistance, usually less than 150°C, except for special blends used in aerospace and avionic applications. - Huge drop of volume resistivity at the glass transition point (T_g).
Combinaison silicone époxy Silicone epoxy combination	It is possible to combine the two filling modes, by performing two successive layers of filling, silicone and epoxy or epoxy and silicone, each of the two resins providing some of its advantages and overcoming the disadvantages of the other.		
Perles de verre Glass beads	We have developed this type of tube end insulation to meet the demands of hermetic heaters. Tube end is sealed by a special glass bead molten at high temperature. They are perfectly suited in areas with high air humidity or sporadic use	<ul style="list-style-type: none"> - Applications in high temperatures (up to 450°C) - Moisture porosity near zero. Test elements, of our manufacturing process, measured after 5 years of storage in humid subtropical climate still have an insulation resistance higher than 20Gohms. 	<ul style="list-style-type: none"> - Increased manufacturing cost - Mechanical fragility of the glass.

Because of permanent improvement of our products, drawings, descriptions, features used on these data sheets are for guidance only and can be modified without prior advice



A - 13 Insulation resistance testing vs temperature on tubular heaters end seals only. (Made on 10mm OD tubes with dia. 4mm connection rod)

Epoxies	Silicones	Glass beads
<p>Only one (# 5) has an electrical insulation higher than 1Gohm at 110°C.</p>	<p>The three tested silicone resins retain excellent insulation up to 110°C, but with a huge disparity. Only one (# 1) has an electrical insulation higher than 1Gohm up to 300°C.</p>	<p>The variability between the different types of glass beads is very significant, depending on the melting temperature. One (# 5) retains an electrical insulation higher than 1Gohm above 300°C.</p>

A - 14 Measurement of insulation resistance, leakage current

Standard conditions of moisture absorption measurement testing are usually 1000 hours or six weeks at 65°C and 90% relative humidity.

These thermal aging tests were made more stringent in the method developed in our laboratory, where products placed in a climate chamber, undergo 50 to 80°C repetitive thermal cycles of one hour, which by expanding and contracting the inner residual air inside tubular heaters, accelerates porosity rate.

These tests helped to develop reliable technical solutions.

Our standard end sealing process reaches stabilization of the moisture porosity at 10 Gohms after 1000 hours in adverse conditions, which is 5000 times the value requested by standard for new heaters in standard atmospheric conditions.

Below are result of comparative tests with traditionally isolated tubular heaters which are considered having reached a very good value of 100 megohms (0.1Gohms) (blue curve) and standard tubular heaters from our actual process (yellow curve)

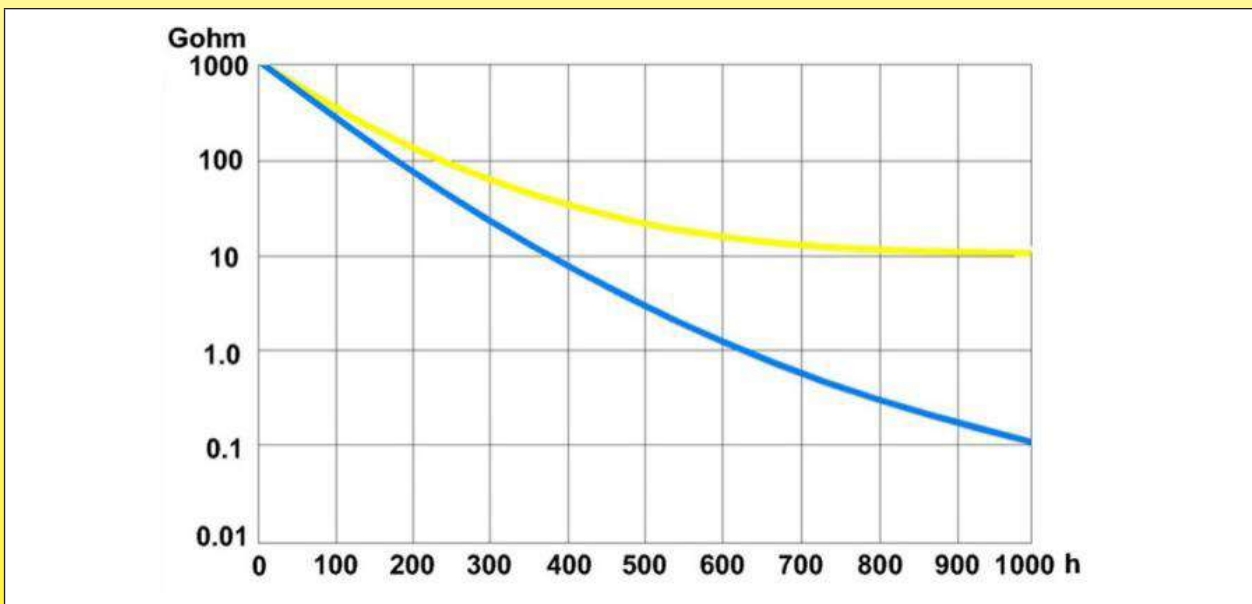

A - 15 Note about insulation resistance measurements

When the insulation measurement is performed on three-phase heating elements or single phase heating elements wired in parallel, by connecting together live terminals, Ohm's law applies, and the result differ from the individual measurement of each heater.

E.g.: 3 heaters in parallel having each an insulation value of 10 Gohms will give a total insulation value 3.33 Gohms by application of the formula $1/R = 1/R1 + 1/R2 + 1/R3$

Because of permanent improvement of our products, drawings, descriptions, features used on these data sheets are for guidance only and can be modified without prior advice



A - 16 Magnesium oxide thickness vs insulation value and water vapor recovery

Sheathed tubular heaters are composed of a coiled heating wire of variable diameter, insulated by magnesia powder, and embedded in a metal tube which is then compacted by swaging to reduce its diameter. There are many external diameters of the tubes, the most common of from 6.25 to 12mm. **For reasons of reliability and durability, heaters of this catalog use only dia. 8mm and dia. 10mm tubes, filled with the highest quality magnesia.** The tube wall thickness is variable according to the diameters, as they must meet the swaging stress, withstand the bending, insure mechanical strength, whilst trying to reduce its weight, and therefore the cost of raw material used. **Tubes with too thin walls will be subject to cracks or micro-cracks during bending operations, or subsequently, after a certain number of heating cycles.** To characterize the advantages and disadvantages of different diameters, we conducted tests involving insulation, and moisture absorption versus different diameters, on some samples. According diameters, the thickness of magnesia insulation varies from one to three. **This magnesia thickness directly determines the insulation resistance.**

These tests were performed with pure magnesia, not having received a silicone surface treatment, because it disappears during annealing made before bending.

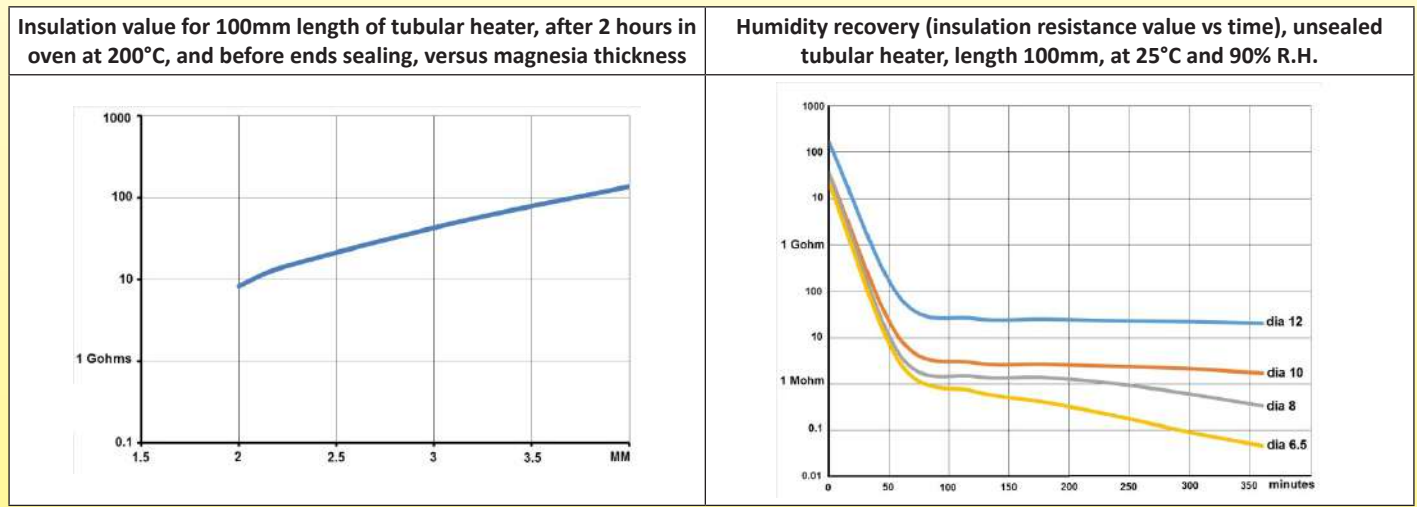

A - 17 Effect of temperature on the insulation resistance of compacted magnesium oxide

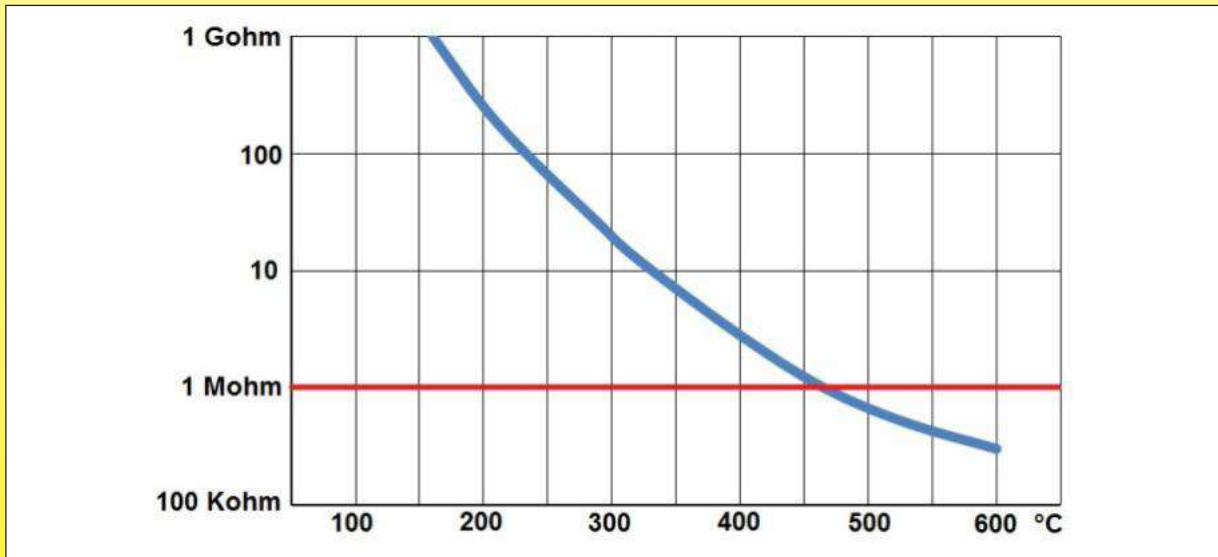

Insulation value versus temperature, of a dia. 8mm, length 1200mm sheathed tubular heater. (Measured in an oven, on a previously dehydrated sheathed tubular heater without end seals).

Note: Depending on the selected quality of magnesia and its compression ratio, resistivity may vary from single to quadruple. According to its compaction, the magnesia powder has a thermal conductivity of between 5 and 6 $W \cdot m^{-1} \cdot K^{-1}$. (For compaction measurement, see "ASTM-D-2771-90 Standard Test Methods for Compaction Density of Electrical Grade Magnesium Oxide")

Because of permanent improvement of our products, drawings, descriptions, features used on these data sheets are for guidance only and can be modified without prior advice



A - 18 Insulation distances of sheathed tubular heaters

A particular attention is needed at electrical terminals to meet the clearances and creepage distances requested by the standards according to the voltage and the nature of the environment.

Insulation distances of some usual configurations (Creepage distances are equal to clearances in these models)

Output style	Tube dia. 6.5, rod dia. 2.5	Tube dia. 8, rod dia. 3	Tube dia. 8, rod dia. 4	Tube dia. 10, rod dia. 4	Tube dia. 10, rod dia. 2.5
<p>Connection is made by a tab terminal spot welded on the output rod, at and least at 4mm from the tube</p>					
Distance (mm)	1.3	2.15	1.9	1.4	3.1
Applications possibles	<p>Can be used in 250V, pollution degree 2, with glass bead insulation or class I resin (IRC >600V)</p>	<p>Can be used in 250V, pollution degree 2, with glass bead insulation or class I or II resin (IRC ≥400V) Can be used in 400V, pollution degree 2, with glass bead insulation or class I resin (IRC >600V)</p>	<p>Can be used in 250V, pollution degree 2, with glass bead insulation or class I or II resin (IRC ≥400V)</p>	<p>Can be used in 250V, pollution degree 2, with glass bead insulation or class I resin (IRC >600V)</p>	<p>Can be used in 250V, pollution degree 2, with glass bead insulation or class I, II or III resin (IRC ≥175V) Can be used in 400V, pollution degree 2, with glass bead insulation or class I or II resin (IRC ≥400V)</p>
Output style	Tube dia. 10, rod dia. 3	Tube dia. 10, rod dia. 4	Tube dia. 12, rod dia. 2.5	Tube dia. 12, rod dia. 3	Tube dia. 12, rod dia. 4
<p>Connection is made by a tab terminal spot welded on the output rod, at and least at 4mm from the tube</p>					
Distance (mm)	2.85	2.35	4.1	3.85	3.35
Applications possibles	<p>Can be used in 250V, pollution degree 2, with glass bead insulation or class I, II or III resin (IRC ≥175V) Can be used in 400V, pollution degree 2, with glass bead insulation or class I or II resin (IRC ≥400V)</p>	<p>Can be used in 250V, pollution degree 2, with glass bead insulation or class I or II resin (IRC ≥400V) Can be used in 400V, pollution degree 2, with glass bead insulation or class I resin (IRC >600V)</p>	<p>Can be used in 250V, pollution degree 3, with glass bead insulation or class I, II or III resin (IRC ≥175V) Can be used in 400V, pollution degree 2, with glass bead insulation or class I, II or III resin (IRC ≥175V)</p>	<p>Can be used in 250V, pollution degree 3, with glass bead insulation or class I or II resin (IRC ≥400V) Can be used in 400V, pollution degree 2, with glass bead insulation or class I or II resin (IRC ≥400V)</p>	<p>Can be used in 250V, pollution degree 3, with glass bead insulation or class I resin (IRC ≥600V) Can be used in 400V, pollution degree 2, with glass bead insulation or class I or II resin (IRC ≥400V)</p>

Because of permanent improvement of our products, drawings, descriptions, features used on these data sheets are for guidance only and can be modified without prior advice

Technical introduction

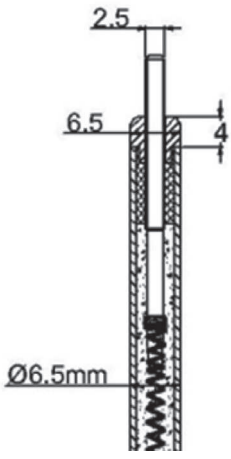
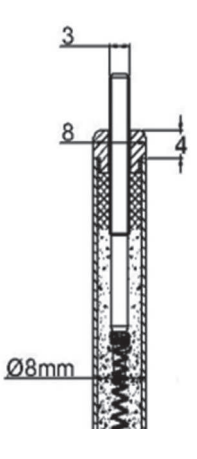
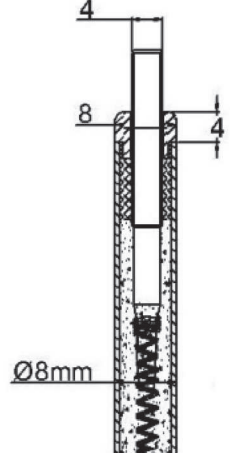
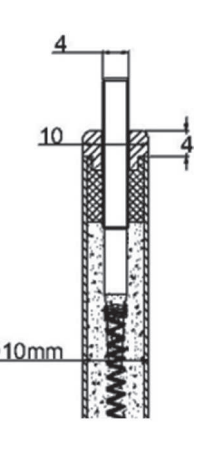
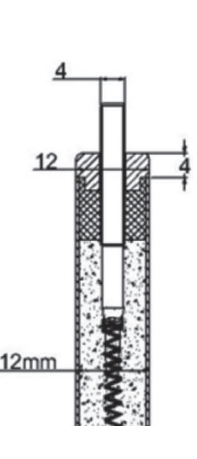
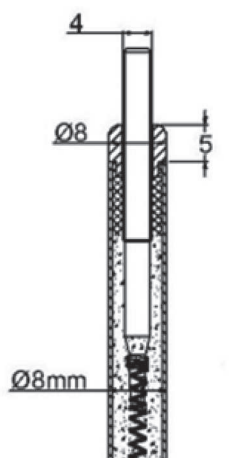
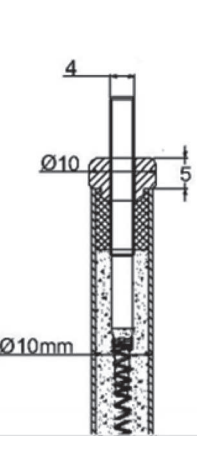
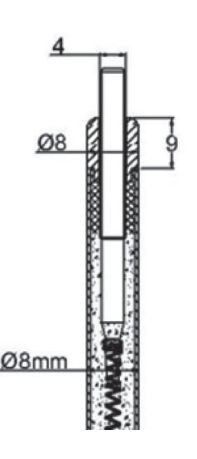
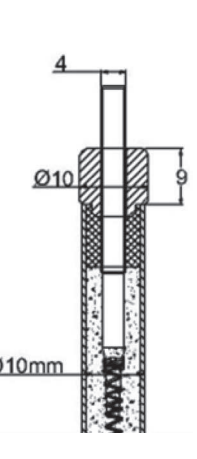

Output style	Tube dia. 6.5, rod dia. 2.5	Tube dia. 8, rod dia. 3	Tube dia. 8, rod dia. 4	Tube dia. 10, rod dia. 4	Tube dia. 12, rod dia. 4
Filling with epoxy or silicone resin, with ceramic insulator, external height 4mm, inner part penetrating the resin Connection is made by nut + securing nut (threaded output rod), but is also possible by a spot welded tab or wire directly welded on the rod (rod without thread)					
Distance (mm)	4	4	4	4	4
Applications possibles	Usable in 250V: Pollution degree 3. Usable in 400V: Pollution degree 2.	Usable in 250V: Pollution degree 3. Usable in 400V: Pollution degree 2.	Usable in 250V: Pollution degree 3. Usable in 400V: Pollution degree 2.	Usable in 250V: Pollution degree 3. Usable in 400V: Pollution degree 2.	Usable in 250V: Pollution degree 3. Usable in 400V: Pollution degree 2.
Output style	Tube dia. 8, rod dia. 4	Tube dia. 10, rod dia. 4	Output style	Tube dia. 8, rod dia. 4	Tube dia. 10, rod dia. 4
Filling with epoxy or silicone resin, with ceramic insulator, external height 5mm, inner part penetrating the resin Connection is made by nut + securing nut (threaded output rod), but is also possible by a spot welded tab or wire directly welded on the rod (rod without thread)			Filling with epoxy or silicone resin, with ceramic insulator, external height 9mm, inner part penetrating the resin Connection is made by nut + securing nut (threaded output rod), but is also possible by a spot welded tab or wire directly welded on the rod (rod without thread)		
Distance (mm)	5	5	Distance (mm)	9	9
Applications possible	Usable in 250V: Pollution degree 4 Usable in 400V: Pollution degree 3	Usable in 250V: Pollution degree 4 Usable in 400V: Pollution degree 3	Applications possibles	Usable in 250V: Pollution degree 4 Usable in 400V: Pollution degree 4	Usable in 250V: Pollution degree 4 Usable in 400V: Pollution degree 4

Because of permanent improvement of our products, drawings, descriptions, features used on these data sheets are for guidance only and can be modified without prior advice



A - 19 Pollution degrees

Rated voltage	Minimum creepage distances for basic insulation (table 20.3, EN60335-1)									
	Pollution degree of the micro-environment*									
	1	2			3			4		
		Material group**			Material group**			Material group**		
		I	II	IIIA, IIIB	I	II	IIIA, IIIB	I	II	IIIA
≤250V	0.6	1.3	1.8	2.5	3.2	3.6	4	5	6.3	8
≤400V	1	2	2.8	4	5	5.6	6.3	8	10	12.5

** The pollution degrees 1, 2, 3 and 4 apply to components such as tubular heaters or liquid heaters. Pollution degree 4 is not applicable to devices. The micro-environment is the immediate environment of the insulation which particularly influences the dimensioning of the creepage distances

- Pollution degree 1: "No pollution or only dry, non-conductive pollution occurs. The pollution has no influence". This pollution degree is not applicable to the heaters of this catalog
- Pollution degree 2: "Only non-conductive pollution occurs except that occasionally a temporary conductivity caused by condensation is to be expected". This level of pollution is the most common in the heating household appliances.
- Pollution degree 3: "Conductive pollution occurs or dry non-conductive pollution occurs which becomes conductive due to condensation which is to be expected." This pollution degree is common in all the electrical appliances that can produce cold.
- Pollution degree 4: "The pollution generates persistent conductivity caused by conductive dust or by rain or snow." This pollution degree is possible on heaters used in reversible air conditioning systems, in which condensation occurs on components located above, that may lead to the creation of water drops.

** **Material group.** The relationship between material group and proof tracking index (PTI) values is found in 6.13. The PTI values refer to values obtained in accordance with IEC 60112, and tested with solution A.

I: IRC ≥600. Ceramics and glass are classified in this category without testing. Organic materials such as plastics are subject to certification testing to determine their classification in Group I to IIIB

II: 400 ≤IRC <600

IIIA: 175 ≤IRC <400

IIIB: 100 ≤IRC <175



B - Tanks body design rules

B - 1 Reasons for use of 1.2mm stainless steel

The choice of stainless steel was obvious as the heaters must be used in drinking water circuits, swimming pools circuits, and liquids commonly used in central heating systems.

Heaters of this catalog are designed to have only stainless steel in contact with the water, to the exclusion of any weld filler metal or solder strippers, resins and plastics materials. The result is that they are fully compliant with the WRAS and KTW standards.

- Stainless steel alloys, especially the austenitic have elongation rates of up to 60%, facilitating forming.
- They have an excellent aptitude for TIG welding.
- They have all good resistance to corrosion.
- The AISI 316 * grades are particularly resistant to water disinfectants, including welded zones.
- They are readily available in sheets, tubes, bars and tubular blanks, allowing the realization in the same material of all components of the tank, stamped or machined.
- The passivation by immersion after the complete assembly is possible without contamination of the bath by brazing alloys or solder.
- The 1.2mm is required to insure a pressure resistance compatible with the domestic water supply networks, while maintaining a substantial margin of safety.

B - 2 Effect of welding interstices on corrosion

When two components are welded side by side, the weld must be made to the root and penetrate the entire thickness of the two walls. Incomplete welding leaves a gap which will initiate corrosion, especially by the deposition of foreign metal particles.

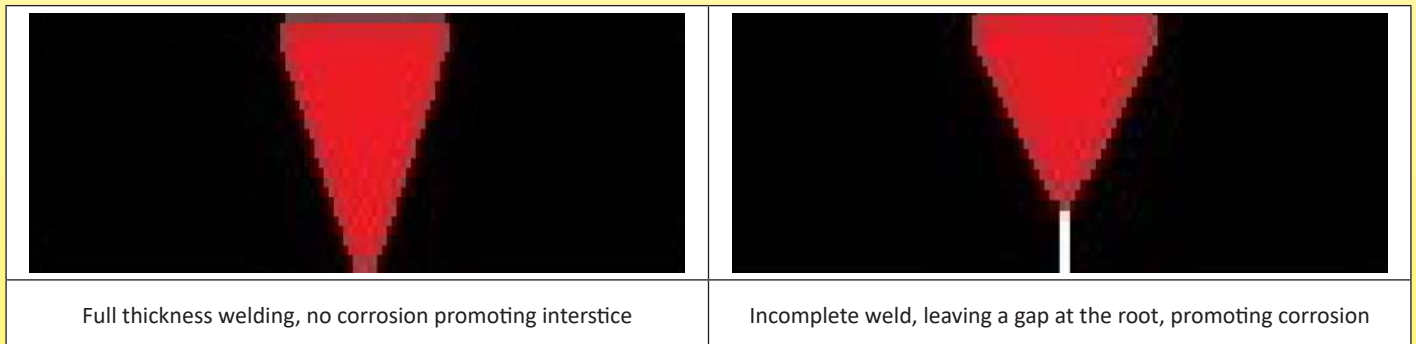



B - 3 Water hammer shocks

Water hammer is a shock wave in the installation. A heater itself does not produce water hammer, it is caused by a fast stop of the water circulation, usually by snap action valves, and results in strong pressure fluctuations generated by a sudden deceleration of the moving water. These pressure variations are much more significant than the water velocity is high and the closure is rapid. The duration of the shock wave is of the order of 0.2 to 0.5 seconds.

The maximum pressure generated during a sudden interruption of flow is given by the Joukowsky equation:

$$P = \rho c U$$

With

P = Pressure (Pa)

ρ = density of the liquid (kg/m^3)

c = speed of sound in the fluid (= 1480m/s for water)

U = liquid velocity (m/sec)

For example, in a heater with water flow speed of 1 m/s:

$$P = 1000 \times 1480 \times 1 = 1.48\text{Mpa}$$

In practice, these shock waves are reduced by the length of pipe between the point of production and the tank. But the constraints made to the tank are important and can lead, in extreme cases, to fatigue cracks, generally due to design errors allowing metal walls bending.

The products in this catalog have been designed to withstand over 1,000,000 water hammer shocks with a ΔP of 20 bar and 0.2s

Main causes of water hammer shocks

- Snap closing of a tap.
- Washing machine solenoid valve.
- Pump start
- Pump stop
- Block valve closure
- Contact of cold liquid with a condensable vapor.

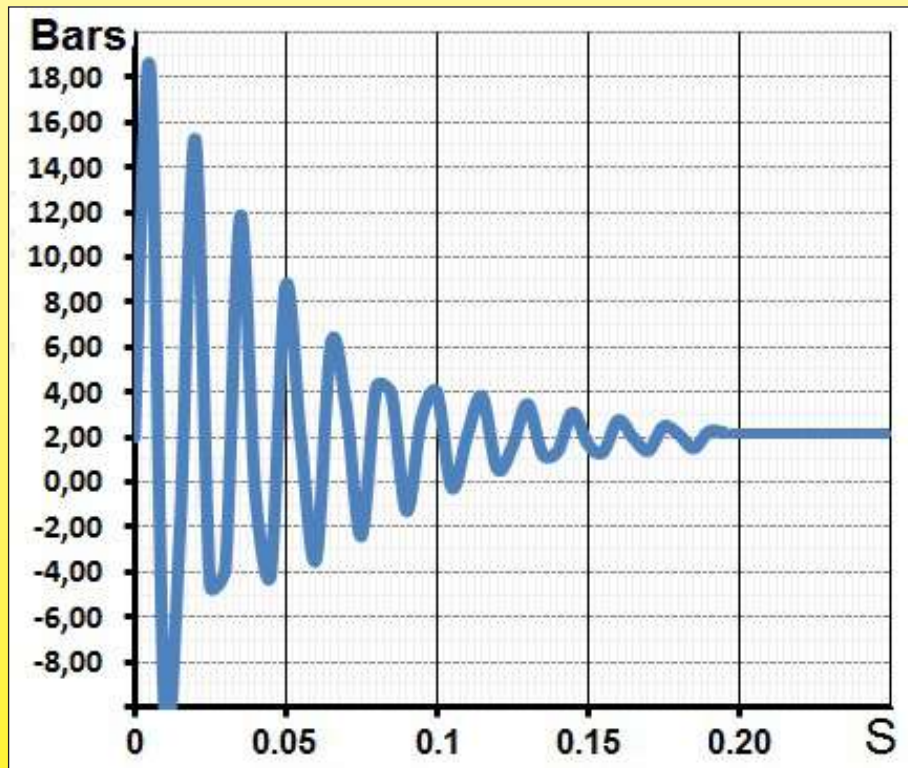

Typical form of the shock wave during a water hammer shock in a 125mm diameter tank, 2 bar water pressure, and water velocity 0.5m /s in the pipe circuit.



B - 4 Pressure resistance upon flanges design

The pressure resistance of tanks and distortions that appear is based on the shape given to them.

It is the same to their resistance to accelerated aging tests, simulating water hammer shocks in applications, that very quickly result in fatigue cracks.

If simple flat ends are easily achievable, and may seem economic at first glance, their pressure resistance is limited and request a greatly increased wall thicknesses to achieve similar performance. Their economic advantage then disappears. To allow you to view the differences that appear, we performed comparative tests on tanks 100mm dia, length 100mm, AISI 304 steel 1.2mm thick, TIG welding made without filler metal.

These tests help explain why we prefer dish shaped flanges.

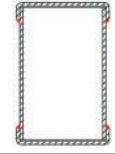
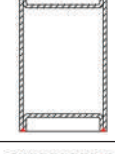
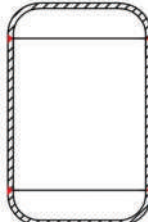
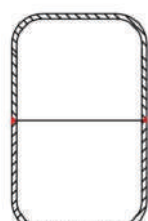
Flanges design	Features	Advantages	Disadvantages	Pressure for 1mm bending at flange center (Mpa)
	End closed by a flat flange, side by side TIG welded.	- No tooling cost involved	- Significant distortions even at low pressure. - Very low pressure resistance - The lowest bursting pressure - Fatigue cracks appearing soon at the welding seam	0.55Mpa
	End closed by a flat flange with outer rim.	- Simple solution to implement, the pieces fit together in one another. - Design facilitates brazing. - Simple stamping dies	- Important interstices promote corrosion by foreign particles. - Low pressure resistance. - Fatigue cracks rapidly occurring at the 90° bending of the flange rim.	1.15Mpa
	End closed by a flat flange with inner rim.	- A simple to implement solution, parts penetrating each others. Most of time, the flange is TIG welded, because it is easy to make. - Simple tooling	- Important interstices promote corrosion by foreign particles. - The lowest pressure resistance. - Fatigue cracks rapidly occurring at the 90° bending of the flange rim.	0.32Mpa
	Dish shaped flange. Side by side TIG welding	- The best pressure resistance. - The longest life to ageing tests. - The largest internal volume for the lowest weight of raw material. - No gap favoring corrosion by foreign particles. - The rounded design avoid dead zones and sludge deposition.	- Medium cost of stamping and forming tools	2.3Mpa
	2 deep drawn dish shaped flanges, side by side TIG welded	- The shortest welding seam length - The best pressure resistance. - The longest life to ageing tests. - No gap favoring corrosion by foreign particles. - The rounded design avoid dead zones and sludge deposition.	- The length of each half-shell is limited to 1 to 1.5 times the diameter of the tank. For example, a 10mm dia. tank will be limited to 250mm long. - The most expensive dies. - Greater material losses than the previous solution.	2.3Mpa

Measurement of the total elongation of the tank as a result of the flanges deformation vs pressure (tests made on 100mm dia. tanks, 304L stainless steel sheet 1.2mm thick)

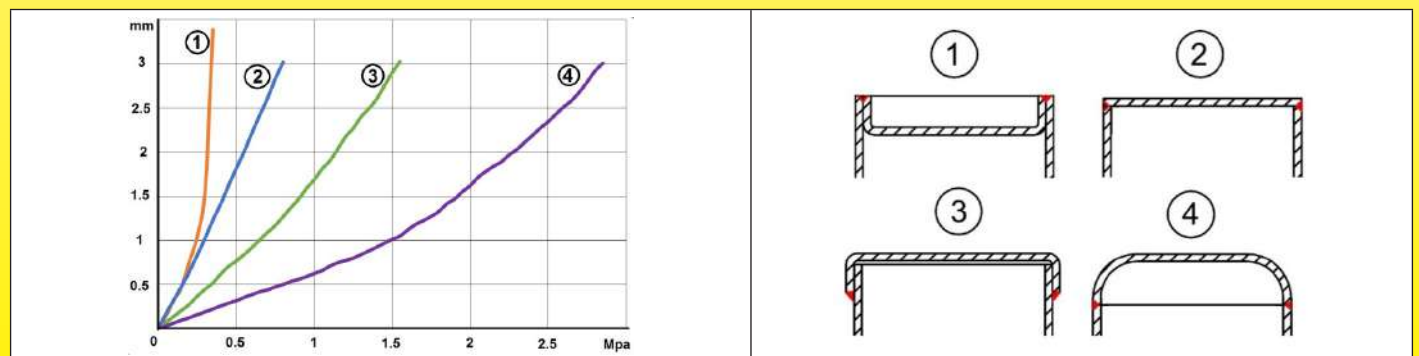

Because of permanent improvement of our products, drawings, descriptions, features used on these data sheets are for guidance only and can be modified without prior advice



B - 5 Leaks testing

Water leaks are the main risk of the heaters tanks.

They are generally caused by invisible micro-gaps and pin holes in the welds. These defects can be a discontinuity in the weld, or a foreign particle.

In the case of shells assembled by torch brazing or by induction, this foreign matter is often a droplet of brazing flux (Usually borax). This type of foreign body causes leakages which cannot be found in the quality control process, as the hardened borax seals the leak until it dissolves in water. This can take days. Leaks thus appear well after the leak tests, and generally in the field after delivery of the finished product.

This defect does not appear with the vacuum or controlled atmosphere furnace brazing processes, but in this processes all the parts are subjected to temperatures up to 650°C (capillary brazing alloys with silver / copper) to more than 900°C (with solder copper-nickel alloys), which can lead to sensitization of stainless steel (see below the section on corrosion), if these operations are not followed by an appropriate heat treatment.

This defect does not appear in the TIG welds made without filler metal as the protection during welding is performed by gases.

This explains why the tanks we manufacture do not use brazing or soldering with filler or flux.

Leak testing is done 3 times consecutively by 3 different teams and by different methods. The detection of micro-leaks is particularly difficult, and the human factor does not provide a 100% proof result with a single test.

Statistically, the detection rate is 99.2% in the first test, 99.93% in the second test and more than 99.999% in the third test.

B-6 Inlet and outlet pipe sizing upon pressure drop and flow

Tests done on-line heaters, water at 50°C, male threads. Pressure drop in millibars and flow in liters per minute.

The pressure drop of online heaters is usually nearly equivalent to 1 meter of pipe.

Pressure drop must be increased by 25% when the inlet and the outlet are angled at 90° and 60% when the inlet and the outlet are perpendicular to the body of the heater.

If installed, internal accessories such as flow deflectors or grids increase the loss.

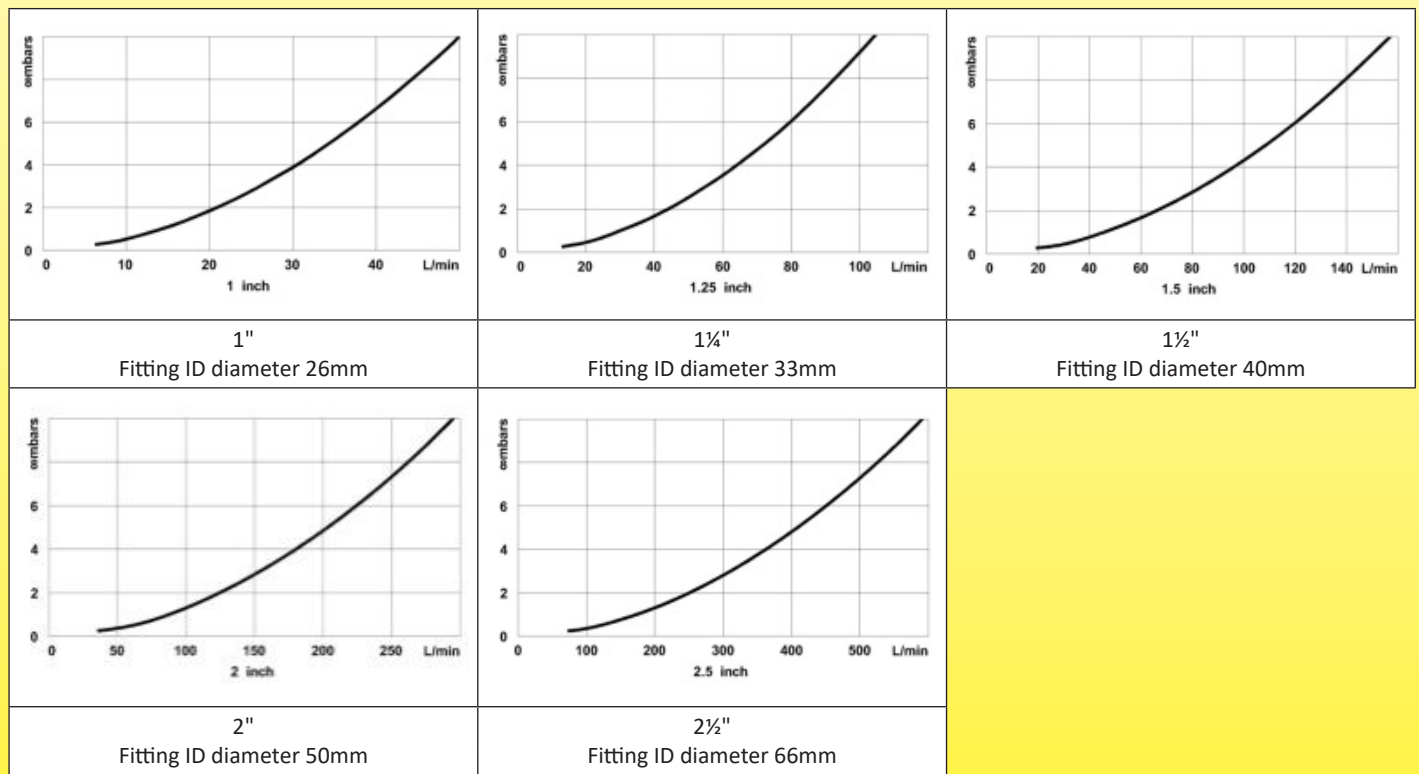

B - 7 Tanks and heaters installation position and dead zones

There are two types of dead zones:

- Those which will collect air: The air may come from the degassing of the system water or from poor drainage. Once installed, the heaters should be in a position that prevents the accumulation of air bubbles inside the tank. The air bubbles are thermal insulators, and they may cause an erroneous measurement of the temperature, trigger the thermal fuse cut out, or erroneous functioning of thermostat and local overheating. If the tubular heaters are not properly submerged, it may cause fire hazard and/or equipment damage.

A permanent degassing must be done to avoid stagnant air in the circuit. The use of an automatic air vent is required in most cases.

- Those which will accumulate oxides and sludge deposits: The oxide deposits are typically made of ferrous or ferric oxide, from other parts of the heating circuit, so that the sludge produced by the decomposition of glycol, and may initiate pitting corrosion points.

B - 8 Exemples of wrong design or wrong installation

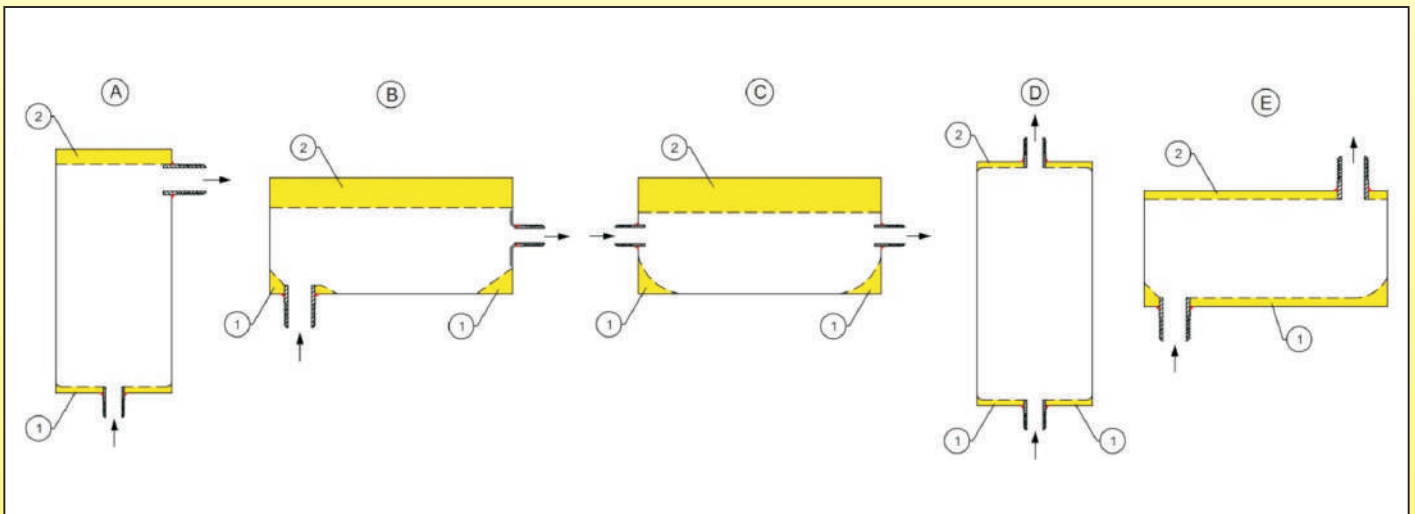

The pictures A, B, C, D, E show misconceptions and bad installation positions of heaters, with **mud deposit areas (1)** or **air accumulation (2)** and also internal sharp corners promoting accumulation of particles

B - 9 Exemples of efficient design and installation

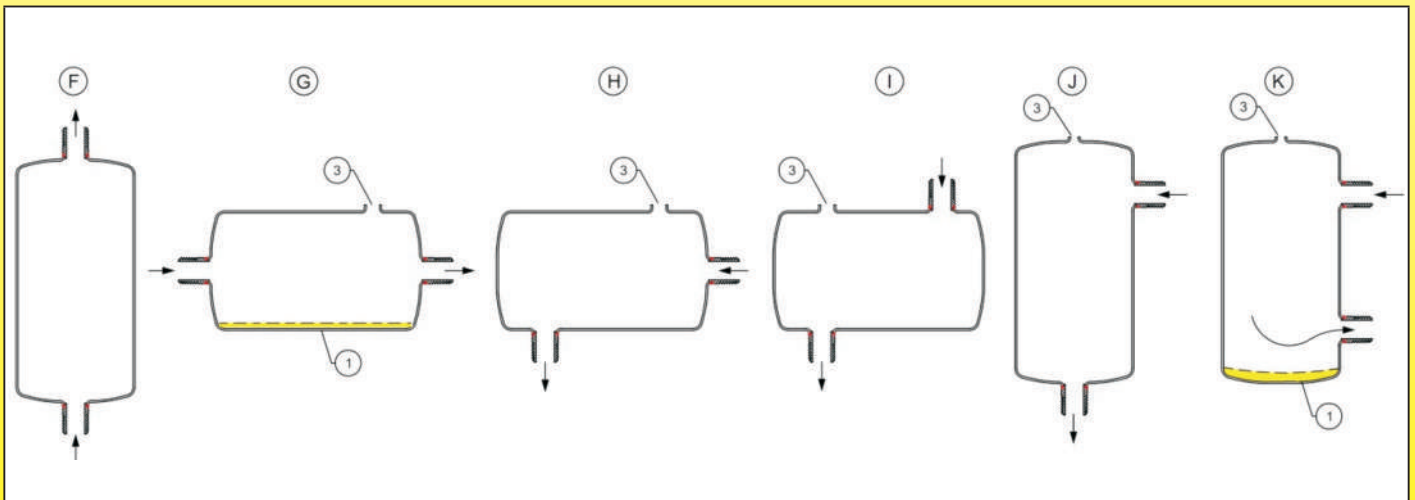

Drawings F, H, I, J show designs with rounded angles. Air pockets are avoided by the position (F), or by the presence of air vent (3). Sludge deposits are avoided if the flow direction is respected. Drawings G and K show a risk of sludge deposition and may require a drain hole at the lowest part (1)



C - Water inlet and outlets connection on tanks

C - 1 Fitting threads use for main inlet and outlet and for auxiliary circuits

In Europe, parallel threads according to ISO228-1, also said BSPP, cylindrical gas thread or "G", are the most commonly used. These threads are still sometime described, particularly in France, according to their internal and external diameters.

These parallel thread pipe joints require a **gasket seat** and a **gasket** to ensure proper sealing.

Tapered threads, ISO-7, also known as BSPT, or "R" are rarely used. Their sealing is provided on the thread.

Although not recommended, it is optionally possible to connect a tapered male thread on a cylindrical female thread, but it also requires the use of a sealant on the threads.

A frequent source of problems in threaded joints is the tolerance on the threads. These are usually controlled with Go/No-Go gauges, and because due to their own manufacturing tolerances, there are no two identical gauges, and that the standards adds levels of wear. It is common that products whose dimensions comply with the standards are rejected with a gauge and agreed with another because of these problems.

The ISO228-2 and ISO 1502, deal with the difficulties of this type of control with gauges (see in particular § 11 of ISO 1502 that explains the Taylor principle)

In large quantity applications, quick connections replace inlet and outlet threaded fittings.

C - 2 Hydraulic connection examples

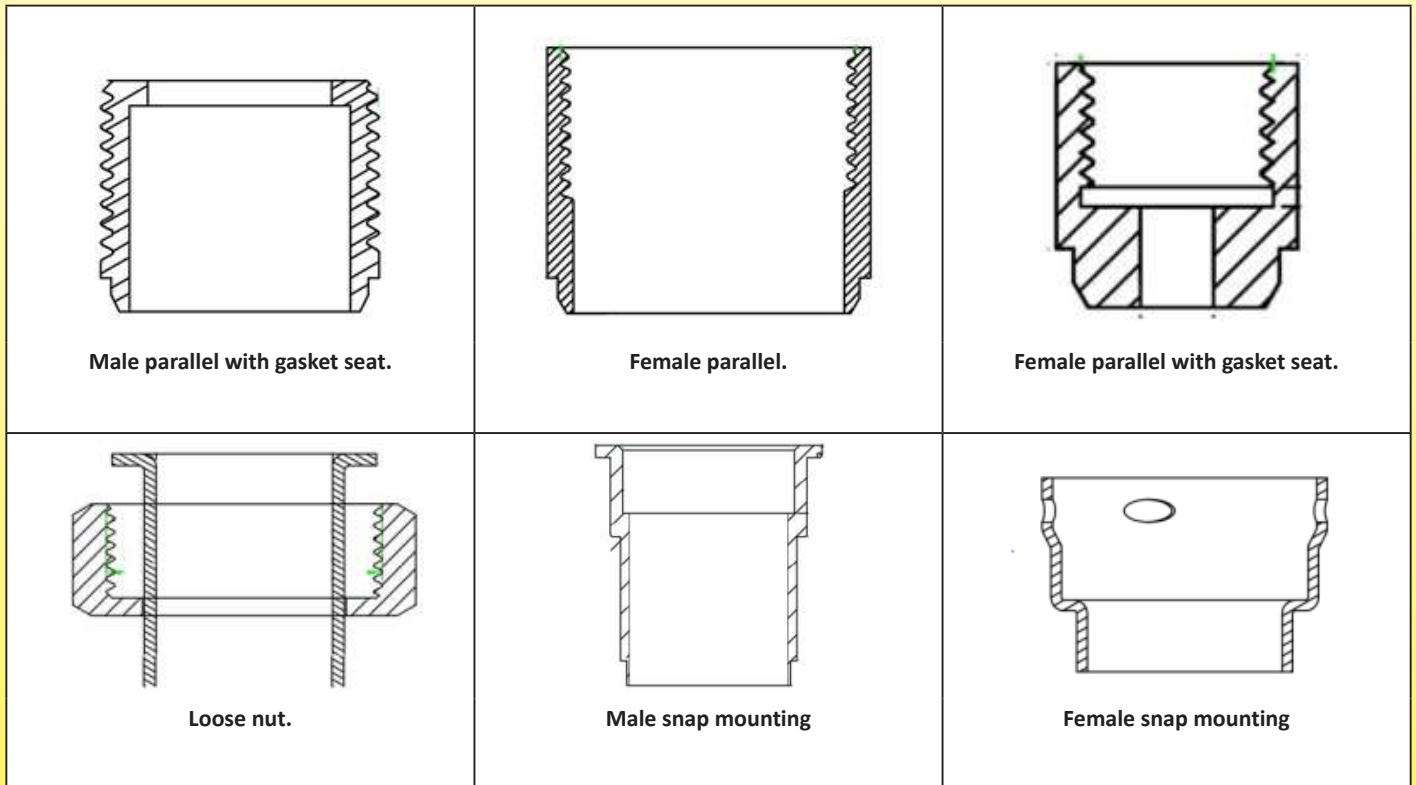



C - 3 Usual threads dimensions

Sizes	Used in auxiliary circuits, for air vents, drain holes, pressure taps etc...					Used in heat pumps auxiliary heaters, electric heating boilers, washing machines heaters, etc...			Used in swimming pools and spas heaters	
	⅛" (5-10)	¼" (8-13)	⅜" (12-17)	½" (15-21)	¾" (20-27)	1" (26-34)	1¼" (33-42)	1½" (40-49)	2" (50-60)	2½" (66-76)
Standard size	10.2mm	13.2mm	16.7mm	21mm	26.4mm	33.3mm	41.9mm	47.8mm	59.6mm	75.2mm
Outside dia.	DN6	DN8	DN10	DN15	DN20	DN25	DN32	DN40	DN50	DN65





C - 4 Threaded connections solutions

Types	Features	Advantages	Disadvantages
	Fitting welded in a hole drilled in a tube wall	No need for tool, die or or special equipment	<ul style="list-style-type: none"> - Huge difficulties to properly adjust the perpendicularity. - Difficulties in properly adjust the external length. - Causes of dead zones in the tank (Yellow on drawing) - 3D welding seam, difficult to achieve, and automation is difficult
	Fitting fitted and welded in a rim extruded from tank wall.	<ul style="list-style-type: none"> - Excellent angular positioning. - Excellent positioning length. - Welding seam and assembly simple and easy to automate. - The fitting is self-positioned in his nesting - Allows welds on thick wall thicknesses fittings - No dead zones in the reservoir 	<ul style="list-style-type: none"> - Tools required for cutting the hole that must be oblong. - Expensive forming tools for the extruded rim.
	Fitting or tube welded side by side on a rim extruded from tank wall.	<ul style="list-style-type: none"> - Excellent angular positioning. - Excellent positioning length. - Welding seam and assembly simple and easy to automate. - No dead zones in the reservoir 	<ul style="list-style-type: none"> - Tooling required to insure concentricity - Tools required for cutting the hole that must be oblong. - Expensive forming tools for the extruded rim. - Shortly suitable for fittings with thick walls.
	Thread formed directly on the tank wall by flowdrill	<ul style="list-style-type: none"> - No drilling. - No welding. - No loss of material. - Excellent angular positioning. - Good gasket seat surface. - The most economical solution. 	<ul style="list-style-type: none"> - Causes a dead zone in the tank - Feasible only in small diameters ⅛" and ¼" - Tapping after flowdrill is quite difficult.

Because of permanent improvement of our products, drawings, descriptions, features used on these data sheets are for guidance only and can be modified without prior advice

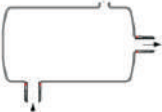

C - 5 Water circuit inlet and outlet main positions

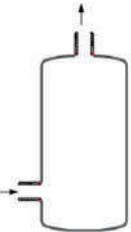
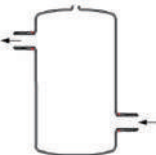
Configuration	Features	Tanks diameter	Fittings size	Advantages	Disadvantages
	In line, vertical mounting	Dia. 70, 76, 80, 88mm	1" for dia. 70, 76, 80; 1" and 1¼" for dia. 88	<ul style="list-style-type: none"> - Can be installed in an existing circuit, simply by removing a vertical pipe section. - No need of an automatic air vent on the tank (but an automatic air vent must, however, be used in the installation) 	<ul style="list-style-type: none"> - The outputs of the tubular heaters are close to the main circuit fitting which imposes particular electrical constraints and requires a long and costly fitting. - The quantity of tubular heaters is limited to 1, 2 or 3 depending on the model - Maximum two pockets.
	In line, horizontal mounting	Dia. 70, 76, 80, 88mm	1" for dia. 70, 76, 80; 1" and 1¼" for dia. 88	<ul style="list-style-type: none"> - Can be installed in an existing circuit, simply by removing a vertical pipe section. 	<ul style="list-style-type: none"> - Automatic air vent is mandatory on the tank - The outputs of the tubular heaters are close to the main circuit fitting which imposes particular electrical constraints and requires a long and costly fitting. - The quantity of tubular heaters is limited to 1, 2 or 3 depending on the model. - Maximum two pockets.
	At 90°, horizontal mounting.	Dia. 88, 100, 125 and 140mm.	1" and 1¼" for dia. 88. 1" to 2½" for dia. 100, 125 and 140mm.	<ul style="list-style-type: none"> - Tubular heaters output on a side without hydraulic fitting. - Up to 4 pockets. - Up to 6 tubular heaters in dia. 125 and 140mm. 	<ul style="list-style-type: none"> - Automatic air vent mandatory on the tank - Difficult to make on small diameter tanks
	At 90°, vertical mounting, side outlet.	Dia. 88, 100, 125 and 140mm.	1" and 1¼" for dia. 88. 1" to 2½" for dia. 100, 125 and 140mm.	<ul style="list-style-type: none"> - Up to 4 pockets. - Up to 6 tubular heaters in dia. 125 and 140mm. 	<ul style="list-style-type: none"> - The outputs of the tubular heaters are close of the mandatory automatic air vent, which is an electrical safety risk - Difficult to make on small diameter tanks
	At 90°, vertical mounting, top outlet.	Dia. 88, 100, 125 and 140mm.	1" and 1¼" for dia. 88. 1" to 2½" for dia. 100, 125 and 140mm.	<ul style="list-style-type: none"> - No need of an automatic air vent on the tank (but an automatic air vent must, however, be used in the installation) - Tubular heaters output on a side without hydraulic fitting. - Up to 4 pockets. - Up to 6 tubular heaters in dia. 125 and 140mm. 	<ul style="list-style-type: none"> - Difficult to make on small diameter tanks
	180° fittings, vertical mounting	Dia. 88, 100, 125 and 140mm.	1" and 1¼" for dia. 88. 1" to 2½" for dia. 100, 125 and 140mm.	<ul style="list-style-type: none"> - Tubular heaters output on a side without hydraulic fitting. - Up to 6 pockets. - Up to 6 tubular heaters in dia. 125 and 140mm. 	<ul style="list-style-type: none"> - Automatic air vent mandatory on the tank - Difficult to make on small diameter tanks

Because of permanent improvement of our products, drawings, descriptions, features used on these data sheets are for guidance only and can be modified without prior advice

Technical introduction

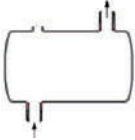
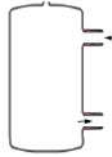
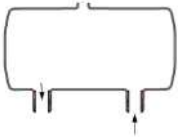
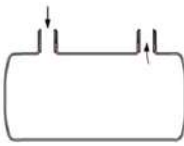

Configuration	Features	Tanks diameter	Fittings size	Advantages	Disadvantages
	180° fittings, horizontal mounting	Dia. 88, 100, 125 and 140mm.	1" and 1¼" for dia. 88. 1" to 2½" for dia. 100, 125 and 140mm.	<ul style="list-style-type: none"> - Tubular heaters output on a side without hydraulic fitting. - Up to 6 pockets. - Up to 6 tubular heaters in dia. 125 and 140mm. 	<ul style="list-style-type: none"> - Automatic air vent mandatory on the tank - Difficult to make on small diameter tanks
	Parallel fittings on same side, vertical mounting.	Dia. 88, 100, 125 and 140mm.	1" and 1¼" for dia. 88. 1" to 2½" for dia. 100, 125 and 140mm.	<ul style="list-style-type: none"> - Tubular heaters output on a side without hydraulic fitting. - Up to 6 pockets. - Up to 6 tubular heaters in dia. 125 and 140mm. 	<ul style="list-style-type: none"> - Automatic air vent mandatory on the tank - Difficult to make on small diameter tanks
	Parallel fittings on same side, horizontal mounting, fittings at bottom side	Dia. 88, 100, 125 and 140mm.	1" and 1¼" for dia. 88. 1" to 2½" for dia. 100, 125 and 140mm.	<ul style="list-style-type: none"> - Tubular heaters output on a side without hydraulic fitting. - Up to 4 pockets. - Up to 6 tubular heaters in dia. 125 and 140mm. - Incorporation of a tubular heat exchanger is possible in 140mm dia. 	<ul style="list-style-type: none"> - Automatic air vent mandatory on the tank - Difficult to make on small diameter tanks
	Parallel fittings on same side, horizontal mounting, fittings at top side	Dia. 88, 100, 125 and 140mm.	1" and 1¼" for dia. 88. 1" to 2½" for dia. 100, 125 and 140mm.	<ul style="list-style-type: none"> - No need of an automatic air vent on the tank (but an automatic air vent must, however, be used in the installation) - Tubular heaters output on a side without hydraulic fitting. - Up to 4 pockets. - Up to 6 tubular heaters in dia. 125 and 140mm. - Incorporation of a tubular heat exchanger is possible in dia. 140mm. 	<ul style="list-style-type: none"> - Difficult to make on small diameter tanks

Because of permanent improvement of our products, drawings, descriptions, features used on these data sheets are for guidance only and can be modified without prior advice



D - Tubular heaters mounting on tanks

D - 1 Tubular heaters assembly methods on the tanks

Tubular heaters fixation methods on the tanks are one of the key elements of the design of the device, and are directly related to the type of application and the lifetime of the unit.

Removable and replaceable heaters are recommended when the liquid is particularly corrosive or mineralized because it is at the hottest place that corrosion will occur and this is also where the limestone deposits will accumulate.

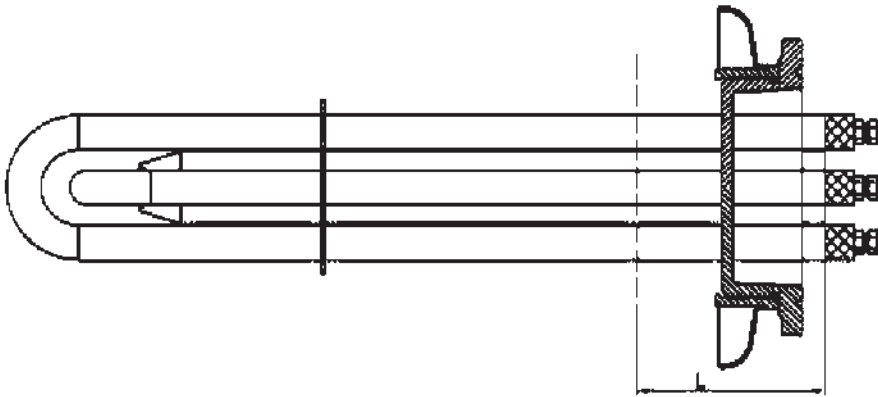

In professional applications, screwed fittings (1" to 2½" or M77 × 2) will be favored, but the limited size of the fitting and its passage diameter quickly arise limits when the heaters must be bent or folded.

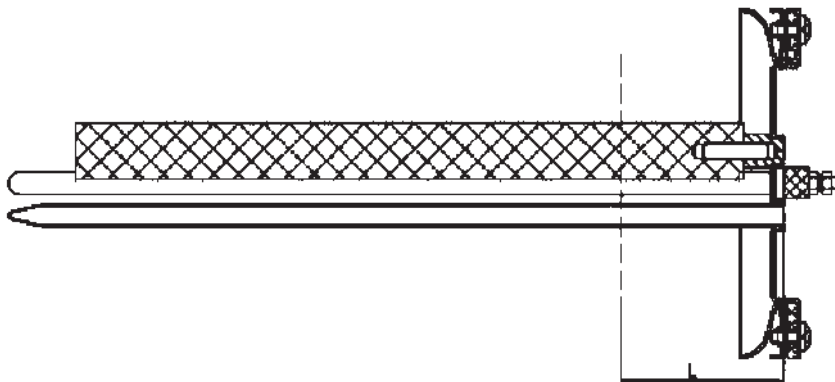

Mounting on a stamped flange is an economical solution of removable heater because it allows large diameters, as well as the installation of magnesium sacrificial anodes
It allows removing easily the heater from the tank, to be able to clean it, remove of sludge and limescale, and replace the anode.

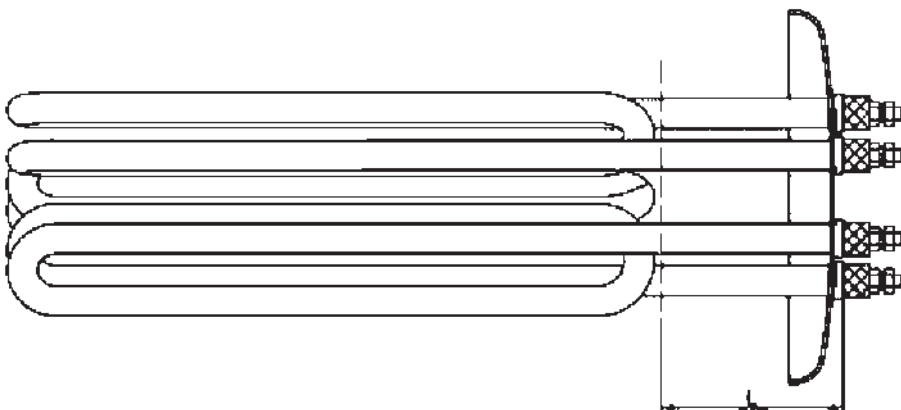

In low mineralized water circulating in a closed circuit, and in low-corrosive liquids, the most economical solution, however, is the direct welding of tubular heaters on the tank wall.
When using good quality tubular heaters, having a good electrical insulation, the assembly will have a lifetime of several years, similar to the other two solutions, at a much lower cost.
It is the most used solution for heaters of this catalogue

Because of permanent improvement of our products, drawings, descriptions, features used on these data sheets are for guidance only and can be modified without prior advice



D - 2 Joining of heating elements on the circulation heater tank

This connection must meet various requirements, including:

- Provide a good seal
- Withstand the temperature of the liquid
- Withstand the surface temperature of the heating element,
- Provide mechanical retention
- Provide corrosion resistance
- Withstand shocks and vibrations during shipment and field use

Type	Sealing	Temperature	Mechanical retention	Corrosion resistance
Tin soldering	Good if no mechanical stress or vibrations. Soldering is difficult on stainless steel.	Max 120°C	Poor to average	Poor
Epoxy bonding	Good if no mechanical stress or vibrations.	Max 80°C	Poor	Good
Copper alloy brazing	Good, but risks of leakage eventually undetectable in production.	Max 300°C	Superior	Average
TIG welding	Superior	Max 450°C (304L)	Superior	Superior

For these reasons our manufacturing process is using TIG welding



D - 3 Maintaining the heating elements tubes

Depending on the shape given to the heating elements, they will be more or less prone to vibration during the passage of the liquid. These vibrations, when significant, are the source of undesirable noise, and more or less rapidly lead to the fatigue fracture of the welding of the heater tube on the tank. It is therefore necessary to use holding devices or grids, which vary with heaters configurations. They also make it possible to maintain firmly the items that can be highly stressed by the road transport conditions in some countries.

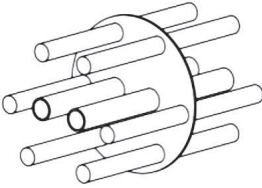
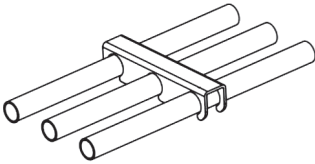
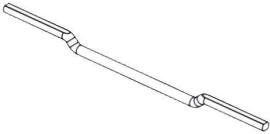
Type	Features	Advantages	Disadvantages
	Washer style grid	<ul style="list-style-type: none"> - Cheap. - Low cost tooling. 	<ul style="list-style-type: none"> - Large pressure drop - Can move and vibrate on tubes. - Can be used only on single hairpin bended heaters. - Cannot be installed or removed after heating elements welding on tank.
	Fork style grid	<ul style="list-style-type: none"> - Good clamping on the tubes - Low pressure drop - Can be mounted on the tubes after tubular heaters welding on the flange - Removable and repositionable - Suitable for all types of heaters, including coiled. 	<ul style="list-style-type: none"> - Expensive tooling - More than one grid can be needed on one assembly.
	Side rod	<ul style="list-style-type: none"> - No pressure drop. - Good centering of coil inside the tank - Cheap 	<ul style="list-style-type: none"> - Only available on coiled tubular heaters.

Because of permanent improvement of our products, drawings, descriptions, features used on these data sheets are for guidance only and can be modified without prior advice

D - 4 Distance between heating elements and tank or tube metal walls

In our design, there is always more than 5mm between the heating element and the tube or tank wall, to avoid heat transmission by conduction or radiation to the tank wall. All the power of the heating elements is therefore used to heat the liquid.

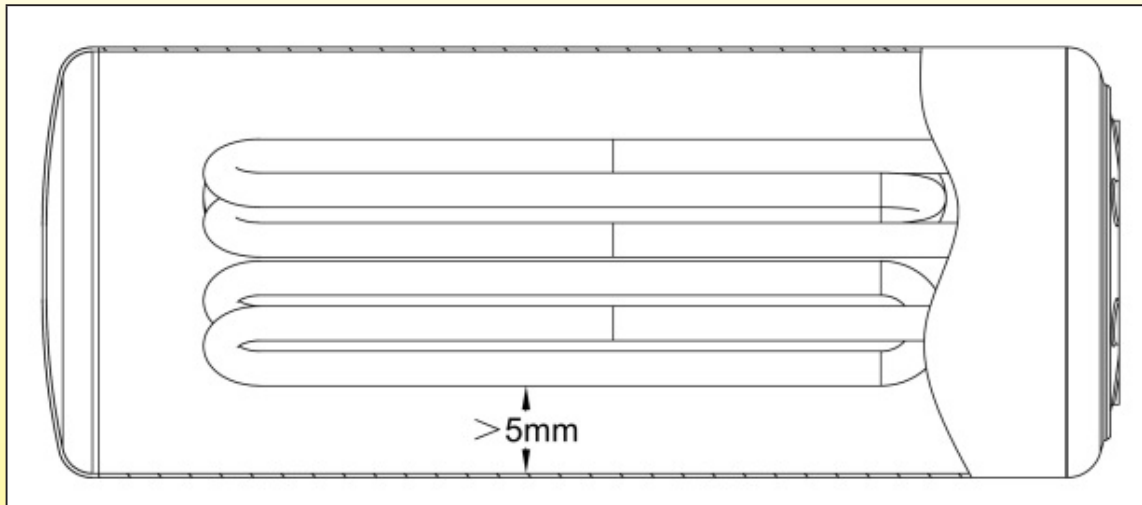



E - Thermowells (Pockets) and TCO installation

E - 1 Pockets design

In heaters, a thermowell must protect a temperature sensor, a thermostat bulb or a thermal cut out against the liquid which it measures the temperature. It must also ensure tightness, corrosion resistance, pressure resistance and ensure good heat transfer between the liquid and the temperature sensing element without increasing the response time. Its positioning is essential for reliable measurement corresponding to its function in the heater.

Function	Solution
Ensuring tightness	TIG weld on the flange and the end
Avoid corrosion	No gaps, tapered tube closure with reduced weld length
Withstand pressure	Adapted wall thickness, tapered tube closure
Ensure good heat transfer	Thin tube wall, small clearance between the sensor and the tube, heat transfer grease.
Optimize the response time	Low mass and optimized positioning
Measure the right temperature	Position on the cold inlet, the hot outlet or another depending on the function of the sensor

E - 2 Comparison of raw materials that can be used in heaters thermowells

Material	Thermal conductivity. ($W \cdot m^{-1} \cdot K^{-1}$)	Tubes internal maximum pressure by standard (Bars)	Specific thermal capacity ($J \cdot ^\circ C^{-1} \cdot g^{-1}$)	Comments
Pure Copper	386	$6 \times 4.4=110$ $8 \times 6=100$ $10 \times 8=80$ $12 \times 9.6=80$ $12 \times 10=60$	0.38	<ul style="list-style-type: none"> - With a same wall thickness, a copper thermowell transmit heat 26 times faster than the same in stainless steel. - At equal weight, copper and stainless steel specific thermal capacities are roughly equivalent. They require the same amount of energy to change in temperature. - To withstand a pressure similar to that of the reservoir, a wall thickness of 1mm is recommended on tubes dia.10mm
304 or 316 Stainless steels	15	$6 \times 4.4= 248$ $8 \times 6=240$ $8 \times 7=120$ $10 \times 8=192$ $10 \times 9=100$	0.51	<ul style="list-style-type: none"> - At equal thickness a stainless steel tube is about 2.5 times stronger than a copper tube. At roughly equal pressure resistance, the wall of the stainless steel tube can be twice thinner that of the copper tube, and thus the heat transfer rate and thermal inertia are then also halved. - At equal weight, copper and stainless steel specific thermal capacities are roughly equivalent. They require the same amount of energy to change in temperature.



E - 3 The 3 solutions to close tube end

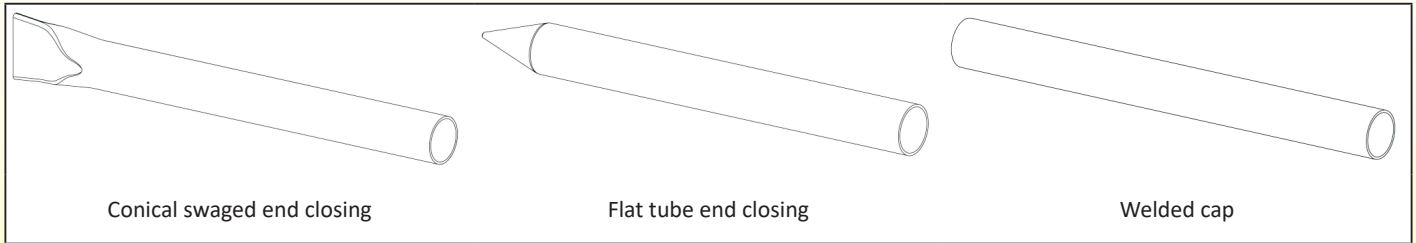

Conical swaged end closing

Flat tube end closing

Welded cap

Solution	Welding	Corrosion resistance	Pressure resistance	Comments
Conical swaged tube end	TIG welding is just a spot at the end of the cone.	Inside part of welding can be protected by welding gas during operation.	Maximum resistance to overpressure. Crushing pressure measured on a 12 × 11mm pocket: - In copper: 3.2Mpa . - In 304L stainless steel: >10Mpa	This solution is the most satisfactory in terms of pressure resistance, and leakage risks are greatly reduced because the weld is reduced to a single point. However, it requires specific equipment for conical swaging. This is the preferred solution in heaters of this catalog.
Flat tube end closing	TIG weld is a long seam, increasing leakage risks.	Due to prior flattening, the protection of the weld inside the tube is impossible, the shielding gas does not penetrate between the two plies.	Pressure resistance is reduced by 50% or more. Crushing pressure measured on a 12 × 11mm pocket: - In copper: 1.6Mpa . - In 304L stainless steel: 3.6Mpa	This solution, although unsatisfactory in terms of corrosion resistance and pressure is most often used by other manufacturers, because it does not require special swaging equipment.
Welded cap	TIG weld is a long circular seam, increasing leakage risks.	Inside part of welding can be protected by welding gas during operation.	When using a cap thickness >2mm, the overpressure resistance is similar to the swaged model. Crushing pressure measured on a 12 × 11mm pocket: - In copper: 3.2Mpa . - In 304L stainless steel: >10Mpa .	This solution, satisfactory in terms of corrosion resistance and pressure, is often used by other manufacturers, because it does not require special swaging equipment. However, its cost is higher because of the need to machine a cap.

Because of permanent improvement of our products, drawings, descriptions, features used on these data sheets are for guidance only and can be modified without prior advice



E - 4 Thermal response time vs thermowell design, normal use

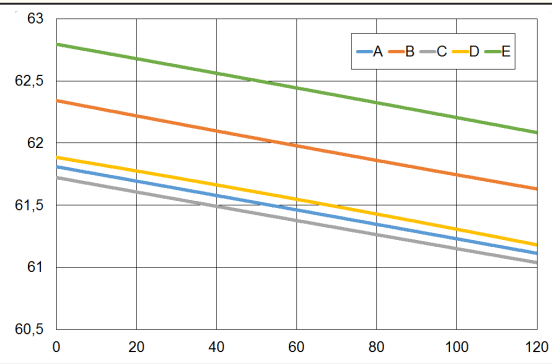
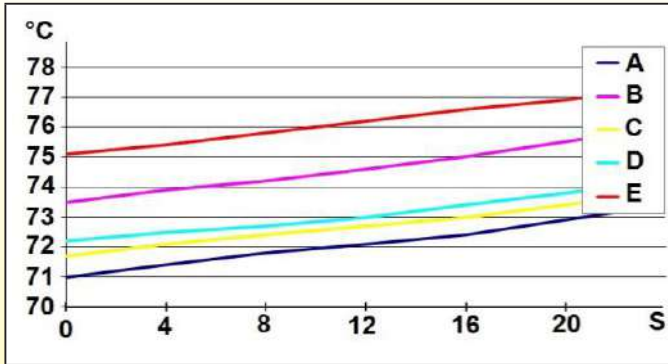

Response time upon a 6°C/min fast temperature rise

A= Copper pocket, without thermal grease
 B= Copper pocket, with thermal grease
 C= Stainless steel pocket, without thermal grease
 D= Stainless steel pocket with thermal grease
 E= Reference sensor, immersed in water without pocket
 Thermal drift vary from 1.5°C to 4°C depending of the pocket selection.

Response time upon a 0.25°C/min slow temperature decrease

A= Copper pocket, without thermal grease
 B= Copper pocket, with thermal grease
 C= Stainless steel pocket, without thermal grease
 D= Stainless steel pocket with thermal grease
 E= Reference sensor, immersed in water without pocket
 Thermal drift vary from 0.5°C to 1°C depending of the pocket selection.

Thermowells length 100mm, 6mm I.D. tube fitted with a 5mm dia. Pt100 resistance temperature sensor. Tube wall thickness is 1mm in copper and 0.5mm copper in stainless steel. Thermowells placed side by side in the same water flow. Preferred solutions in this catalog are 304L or 316L stainless steel thermowells, with 0.5mm gap with the measuring element, and thermal contact grease.

E - 5 Thermal cut-out mounting solutions

The function of the thermal cut out is usually to ensure ultimate safety in case of dry run and failure of other security organs. One of the critical characteristics of thermal fuses is the maximum temperature at which they can be submitted after triggering. A high overshoot after triggering will damage the fuse mechanism and can close again the electrical circuit. They must also trigger quickly, before the body of the tank has reached a temperature at which appear the risk of self-ignition of materials in the vicinity. The positioning of the TCO, their response time, their overshoot after tripping are therefore essential security settings. These parameters are usually adjusted by trial.

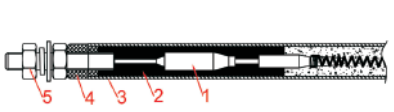
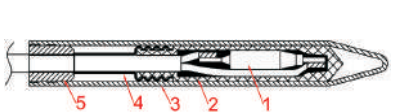
Type	Description	Advantages	Disadvantages
	Thermal cut out built in the tubular heater cold zone. 1: TCO 2: Silicone filling insulation 3: Tubular heater wall 4: Ceramic insulator 5: Tubular heater connector	<ul style="list-style-type: none"> - Low cost - Acceptable response time in case of a slow temperature rise. - Can be mounted in all the tubular heater of a tank 	<ul style="list-style-type: none"> - Available only in dia. 10mm tubular heaters. - Increased cold zone length. - Excessively long response time in case of dry running. - Non replaceable.
	Thermal cut-out inside dedicated pocket. 1: TCO 2: Silicone electrical insulation boot 3: Pocket wall 4: Shrinkable sleeve 5: Anti tear grommet	<ul style="list-style-type: none"> - Fast response time. - Replaceable. - Positioning close to the heating zone of tubular heaters allows adjusting the response time and avoiding subsequent overheating. <p>This is the solution we recommend for heaters of this catalogue</p>	<ul style="list-style-type: none"> - Requires an additional pocket for each TCO - Higher cost.

Because of permanent improvement of our products, drawings, descriptions, features used on these data sheets are for guidance only and can be modified without prior advice

E - 6 Dry run condition, thermal cut out response time vs thermowell distance with tubular heater, for 5W/cm² and 10W/cm²

Dry run detection conditions are characterized by a very fast rapid rise in temperature of the tubular heaters, of the order of 400°C per minute for 10W/cm² heaters. Under these conditions, the response time is critical in order to prevent the temperature of the heating elements reach over 800°C, (destruction appears at about 840°C) or that the tank surface reaches the maximum temperature of the thermal insulation (usually 150°C). For a detection done in accordance with these criteria, the distance between the thermowell of the TCO and tubular heater tube must be as small as possible, and thermal conductivity must be improved, for example by reducing the wall thickness to 5/10mm for stainless steel thermowells tubes. To take advantage of the thermal convection currents, it is important that the thermowell is situated vertically above the tubular heater.

Maximum temperature overshoot allowed for TCO opening at 122°C is limited to 175°C, **because the melting of the internal insulation of the TCO may allow an electrical contact between the two conductors and reauthorize heating.**

Maximum temperature on TCO wiring must not exceed 200°C (FEP insulation), **because the melting of the wires insulation may allow an electrical contact between the two conductors and reauthorize heating.**

Response times higher than 2 minutes at 10W/cm² or 4 minutes at 5W/cm² causes a temperature rise of the upper tank wall up to 150°C (tests carried out at 25°C ambient temperature). Tests described below intend to determine the position limits.

Test description

Tests carried out on 9mm inner diameter, wall thickness 0.5mm, stainless steel thermowell positioned above a single 5W/cm² or 10W/cm² surface load tubular heater, at a variable distance

D. The measured time is the time taken for a thermal cut out calibrated at 122°C to trigger when the resistance is powered.

Thermal cut out is electrically insulated by a silicone boot whose temperature resistance is higher than 220°C. TCO temperature is measured by a thermocouple located inside the silicone boot.

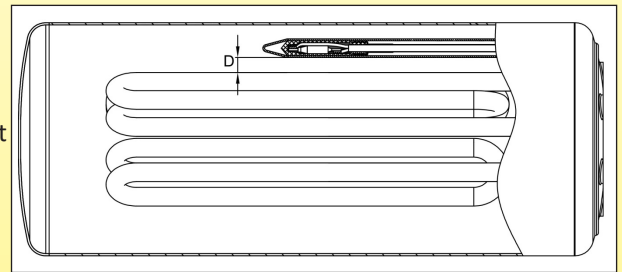

5W/cm²

D (mm)	Pocket Materia	Trip time (min: sec)	Tubular heater surface temperature	TCO temperature overshoot after triggering	Comments
0	SS304	2.08	515	210	- Acceptable response time, - Very low overheating of the tubular heater surface. - TCO overheat temperature out of limit. - Wires temperature out of limit
	Cu	2.18	528	215	- Acceptable response time, - Very low overheating of the tubular heater surface. - TCO overheat temperature out of limits. - Wires temperature out of limit
2	SS304	3.10	634	189	- Acceptable response time, - Very low overheating of the tubular heater surface. - TCO overheat temperature out of limit. - Acceptable wires temperature
	Cu	3.26	636	193	- Acceptable response time, - Acceptable overheating of the tubular heater. - TCO overheat temperature at high limits. - Acceptable wires temperature
5	SS304	3.28	641	145	- Acceptable response time, - Very low overheating of the tubular heater surface. - Acceptable TCO overheat temperature. - Acceptable wires temperature
	Cu	3.50	655	152	- Acceptable response time, - Acceptable overheating of the tubular heater surface. - Acceptable TCO overheat temperature. - Acceptable wires temperature
10	SS304	3.40	637	145	- Acceptable response time, - Very low overheating of the tubular heater surface. - Acceptable TCO overheat temperature. - Acceptable wires temperature
	Cu	4.08	665	145	- Response time at high limit, - Acceptable overheating of the tubular heater surface. - Acceptable TCO overheat temperature. - Acceptable wires temperature



10W/cm²

D (mm)	Pocket Material	Trip time (min: sec)	Tubular heater surface temperature	TCO temperature overshoot after triggering	Comments
0	SS304	1.33	694	267	- Good response time, - Acceptable overheating of the tubular heater surface. - TCO overheat temperature out of limits. - Wires temperature out of limits.
	Cu	1.35	697	265	- Acceptable response time, - Acceptable overheating of the tubular heater surface. - TCO overheat temperature out of limits. - Wires temperature out of limits
2	SS304	2.10	812	264	- Response time at high limit, - Overheating of the tubular heater surface at high limit. - TCO overheat temperature at high limit. - Acceptable wires temperature
	Cu	2.16	832	264	- Response time at high limit,, - Overheating of the tubular heater surface at high limit. - TCO overheat temperature out of limits. - Wires temperature out of limits
5	SS304	2.24	823	167	- Response time at high limit, - Overheating of the tubular heater surface at high limit. - TCO overheat temperature at high limit. - Acceptable wires temperature
	Cu	2.32	840	176	- Response time at high limit, - Overheating of the tubular heater surface out of limit. - TCO overheat temperature at high limits. - Acceptable wires temperature
10	SS304	2.30	830	176	- Response time at high limit, - Overheating of the tubular heater surface at high limit. - TCO overheat temperature at high limit. - Acceptable wires temperature
	Cu	2.35	833	175	- Response time at high limit, - Overheating of the tubular heater surface at high limit. - TCO overheat temperature at high limits. - Acceptable wires temperature

Test conclusions

Reduction of the distance with the tubular heater reduces the response time, but increases overheating on the fuse and wires. Increase the distance between tubular heater and TCO allows to remain within acceptable overheating limits for the TCO and its wires. The impact of the material of the pocket is not very important, and surprisingly the copper pocket have a slightly higher response time than stainless steel, probably because it dissipate more quickly over the entire surface the heat received on a side. In a first approach it may be considered that distances between 5 and 10mm are acceptable under test reserves in the final configuration.

Because of permanent improvement of our products, drawings, descriptions, features used on these data sheets are for guidance only and can be modified without prior advice



E - 7 Results of dry run tests made on heaters with and without thermal fuse

Without thermal cut out

Tested in dry run conditions, **without thermal cut out**, in the most critical conditions, and security systems disconnected, the surface temperature of the heating elements can reach **1000°C** in less than 2 minutes 30 seconds, and the tank wall can reach **800°C** in 7 minutes.

The response time and the surface temperatures are variable parameters depending on the internal configuration of the tank, its volume, the total power and the number of tubular heaters.

Without TCO, heating will stop only when the resistance heating wire is melted by overheating (around 1000-1100°C), or when a current leakage appears that triggers the GFCI.

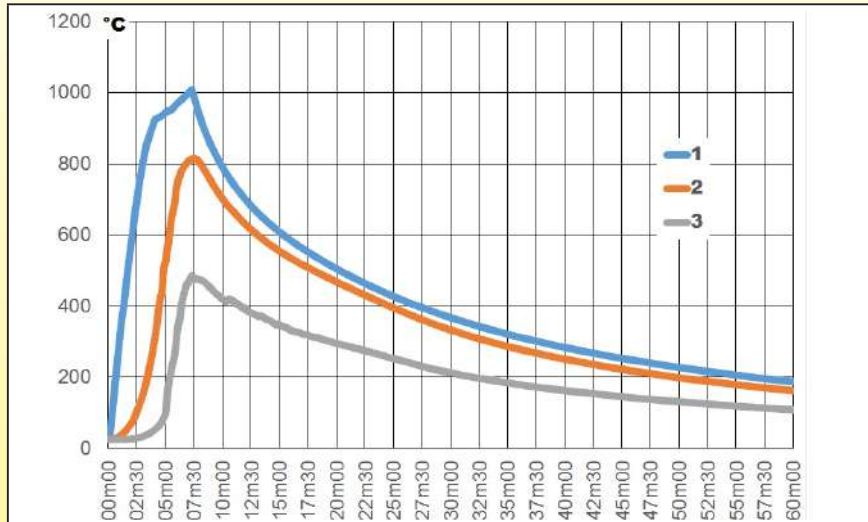

Tests made on liquid heater dia. 125mm, with 3 tubular heaters of 1kw each, surface load **5W/cm²**, with 20mm NBR-PVC foam thermal insulation, and aluminized jacket. **The tank wall temperature rises to more than 800°C. In these conditions, the foam is ignited in less than 7 minutes. (6 min 50s)**

In this test, one can see that two heating elements have melted at 950°C long time before the third one (1027°C, and this has reduced the temperature rise rate.

- 1: Tubular heaters surface temperature
- 2: Surface temperature of the stainless steel tank wall (upside position)
- 3: Surface temperature of the outside of thermal insulation

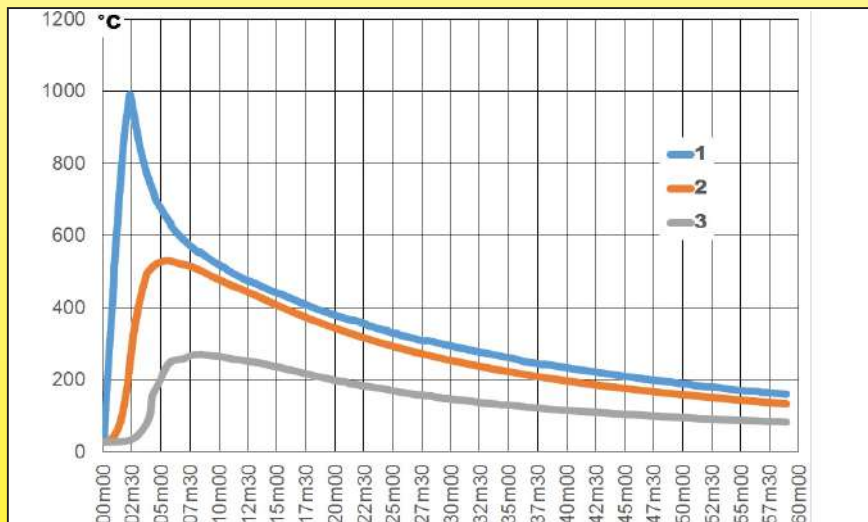

Tests made on liquid heater dia. 125mm, with 3 tubular heaters of 2kw each, surface load **10W/cm²**, with 20mm NBR-PVC foam thermal insulation, and aluminized jacket. **The tank wall temperature rises to more than 520°C. In these conditions, the foam is ignited in less than 3 minutes.**

- 1: Tubular heaters surface temperature
- 2: Surface temperature of the stainless steel tank wall (upside position)
- 3: Surface temperature of the outside of thermal insulation.

Because of permanent improvement of our products, drawings, descriptions, features used on these data sheets are for guidance only and can be modified without prior advice



Because of permanent improvement of our products, drawings, descriptions, features used on these data sheets are for guidance only and can be modified without prior advice

With 122°C thermal cut out.

In the same test with a thermal cut-out, the maximum temperature depends mainly on its position compared to the tubular heaters, then from the installation position and, to a lesser extent, on its functioning temperature "Tf". The TCO must especially bear continuously and without false tripping the temperature of the liquid flowing into the tank. The permanent temperature than thermal fuse can support is defined by the handling temperature parameter "Th" specified on its data sheet. For a thermal fuse with a 122°C "Tf" rated temperature, this value is 94°C. This "Th" value was selected because it exceeds the normal operating temperature of a water heater, and the nominal trigger value is above the thresholds of the other safety devices.

The response times and the surface temperatures reached may vary depending on the internal configuration of the tank, its volume, its thermal insulation, as well as the total power and the number of tubular heaters. **Thus qualifying tests are necessary for each configuration.**

The tests described hereunder were carried out with a thermal fuse with "Tf"= 122°C, and "Th"= 94°C.

It is mounted in a stainless steel thermowell dia. 10mm, wall thickness 0.5mm located at 3~4mm vertically from the upper heating element.

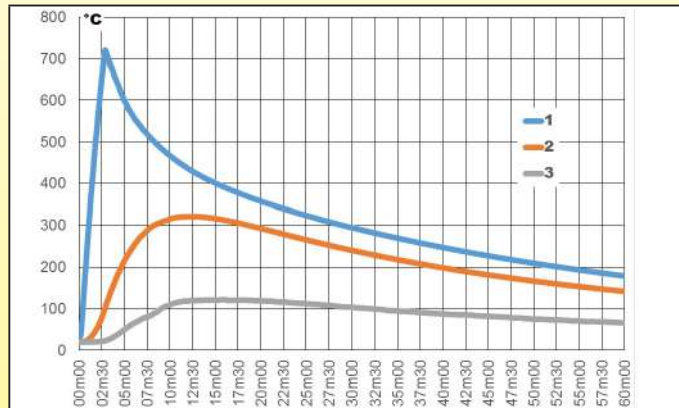

Tests made on liquid heater dia. 125mm, with 3 tubular heaters of 2kw each, surface load 5W/cm², with 20mm NBR-PVC foam thermal insulation, and aluminized jacket. 122°C thermal cut-out.

- 1: Tubular heaters surface temperature
- 2: Surface temperature of the stainless steel tank wall (upside position)
- 3: Surface temperature of the outside of thermal insulation

TCO switches off power in 2 minutes and 50 sec, before heating elements destruction

Stainless steel wall temperature does not exceed 320°C

There is no foam ignition

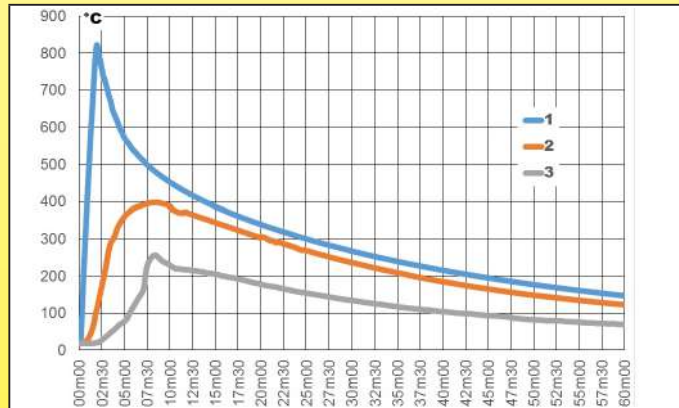

Tests made on liquid heater dia. 125mm, with 3 tubular heaters of 2kw each, surface load 10W/cm², with 20mm NBR-PVC foam thermal insulation, and aluminized jacket. 122°C thermal cut-out.

- 1: Tubular heaters surface temperature
- 2: Surface temperature of the stainless steel tank wall (upside position)
- 3: Surface temperature of the outside of thermal insulation

TCO switches off power in one minute and 45 sec.

Stainless steel wall temperature does not exceed 400°C

There is no foam ignition



F - Surface mounting thermostats

F - 1 Surface mounting thermostat mounting solutions

In heaters of applications, disc thermostats are often used as high-temperature safety of the liquid flowing in the heater. Mounted on the outer wall, their mounting method is critical for proper and fast temperature measurement.

This assembly has to meet requirements about thermal conductivity, ensure good contact with the surface and avoid the risk of galvanic corrosion.

The flat face of the thermostat measuring the temperature by contact with the tank wall, it is important to have an efficient heat transfer, and thus thermal contact grease is recommended.

As a general rule, the surface thermostat must be installed in the upper side of the tank, at a place where there is no risk of air accumulation

Type	Description	Advantages	Disadvantages
	Thermostat with flat bracket, mounted by studs spot welded on surface.	The cheapest solution	<ul style="list-style-type: none"> - Stud solder strength is difficult to check in production. If only one stud breaks, the thermostat does no measure anymore the temperature. - Mounting on cylindrical surfaces is possible, but thermal contact is only on one line.
	Thermostat with flat bracket, slipped under a stainless steel spot welded bracket	<ul style="list-style-type: none"> - Easy and quick assembly - Cheap. 	<ul style="list-style-type: none"> - Difficult or impossible to use on non-flat surfaces. - Thermostat may slip out of the bracket.
	Thermostat with extended cup bracket, pushed on surface by two screws on a stainless steel bracket spot welded on tank.	<p>4 points spot welding in of the stainless steel flange ensures welding safety. The two clamping screws on the thermostat flange ensure a good thermal contact, which remains constant as the result of the flexibility of the thermostat bracket.</p> <p>This is the preferred solution used on heaters of this catalogue</p>	<ul style="list-style-type: none"> - Mounting on cylindrical surfaces is possible, but thermal contact is only on one line. To improve thermal contact, we recommend stamping a flat surface at the thermostat place.
	Thermostat with extended cup bracket, pushed on a copper cup TIG welded through the surface, and secured by two screws on a stainless steel bracket spot welded on tank.	<ul style="list-style-type: none"> - Fast temperature response time, - Can be used as a dry run safety if the distance with tubular heater surface is equal or less than 5mm 	<ul style="list-style-type: none"> - Quite expensive. - Pressure resistance reduced, as the copper wall will distort faster than the tank.
	Thermostat without bracket, inside an epoxy filled deep drawn copper cup TIG welded through the tank wall.	<ul style="list-style-type: none"> - The fastest temperature response time - Waterproof, including the manual reset version - Can be used as a dry run safety if the distance with tubular heater surface is equal or less than 5mm 	<ul style="list-style-type: none"> - Quite expensive. - Pressure resistance reduced, as the copper wall will distort faster than the tank. - Thermostat cannot be removed or changed.

Because of permanent improvement of our products, drawings, descriptions, features used on these data sheets are for guidance only and can be modified without prior advice



F - 2 Disc thermostat sealing solutions

In heaters applications, disc thermostats are mounted on the outer wall, where they may be subject to possible risks of condensation. Their connections may also have to be protected against accidental contact, especially for manual reset models. The introduction of water into the body of a disc thermostat may cause carbonization and possibly inflammation of its plastic body.

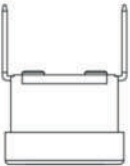
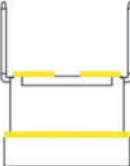
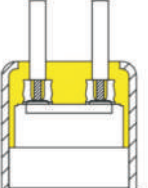
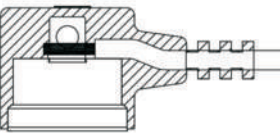
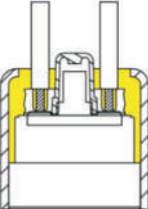
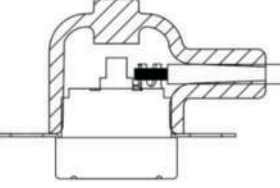
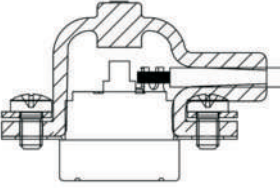
Type	Description	Advantages	Disadvantages
	Unprotected.	The cheapest solution.	<ul style="list-style-type: none"> - No protection against accidental contacts - Approved for use in pollution degree 2 in 250V ("Only non-conductive pollution occurs except that occasionally a temporary conductivity caused by condensation is to be expected").
	Epoxy seals around terminal and bracket crimping.	<ul style="list-style-type: none"> - Good protection against water ingress inside the thermostat 	<ul style="list-style-type: none"> - No protection against accidental contacts - Approved for use in pollution degree 2 in 250V (Only non-conductive pollution occurs except that occasionally a temporary conductivity caused by condensation is to be expected). - Not available in manual reset models.
	Epoxy potting.	<ul style="list-style-type: none"> - Good protection against condensation and water drops. - Good protection against accidental contacts. 	<ul style="list-style-type: none"> - Medium price. - Not available on extended cup bracket thermostats.
	Overmolding	<ul style="list-style-type: none"> - Good protection against condensation and water drops. - Good protection against accidental contacts. - Available on thermostats without bracket, with flat bracket and with extended cup brackets 	<ul style="list-style-type: none"> - Cheaper than epoxy potting. - Not available on manual reset thermostats.
	Epoxy potting with manual reset.	<ul style="list-style-type: none"> - Good protection against condensation and water drops. - Good protection against accidental contacts. 	<ul style="list-style-type: none"> - Medium cost. - Not available on disc thermostat with extended cup bracket.
	Simple silicone boot.	<ul style="list-style-type: none"> - Economical solution - Good protection against condensation. - Good protection against accidental contact. - Can be used also for manual reset models. - Available for all thermostat brackets models 	<ul style="list-style-type: none"> - The boot can be moved during handling and lose its effectiveness. - Not recommended for protection against water drops. - The cable diameter must be respected.
	Silicone boot with securing ring.	<ul style="list-style-type: none"> - Low cost. - Good protection against condensation - Very good protection against accidental contact, it is impossible to remove the boot during handling - Can be used also for manual reset models. - Available for disc thermostats with flat or extended cup brackets <p>The preferred solution used on heaters of this catalogue</p>	<ul style="list-style-type: none"> - Not recommended for protection against water drops. - The cable diameter must be respected.

Because of permanent improvement of our products, drawings, descriptions, features used on these data sheets are for guidance only and can be modified without prior advice

F - 3 Thermal response time when liquid temperature is rising, upon disc thermostat surface mounting solutions

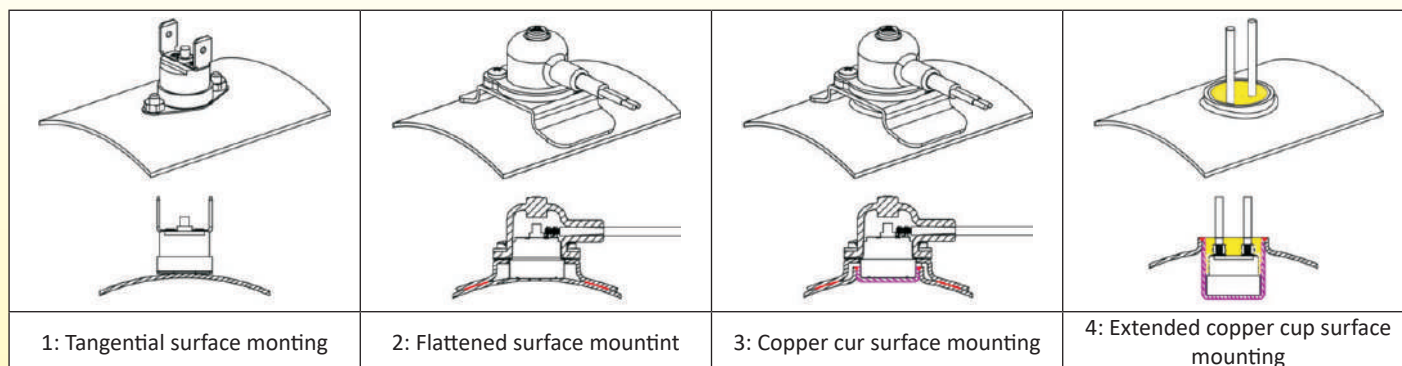

In normal operating condition the temperature of liquid flowing through the heater is stable because it is controlled by a thermostat. Security devices like temperature limiter does not have to trip. To find best temperature limiters positions and mounting, it is important to measure their response times when overheating occurs.

Therefore we conducted tests in two different operating conditions corresponding to two possible failures.

The starting conditions for all tests are:

Water at 50°C, thermostat calibrated at 70°C in the upper position of the tank in a horizontal position.

- The first series corresponds to a slow temperature rise of around 0.4°C and 0.6°C per minute, which can be likened to a failure of the main control system temperature of a 6kW and 9kW heater when the liquid circulates in a loop with 125 liters of water. These tests were made with a 3 speeds circulating pump, to simulate the operation of various pumps. It may be noted that the response time increases with the water flow, as internal water convection in the heater decreases when speed increases. **This important parameter to be considered in the development of a device.** Note: The theoretical time to rise the temperature from 50°C to 70°C is 50 min at 0.4°C per minute and 33 minutes 20 seconds at 0.6°C /min.

- The second series corresponds to a fast temperature rise of 20°C and 30°C per minute corresponding to the water temperature raising in a 6kW and 9kW heater dia. 125mm x 310mm, with an internal volume of 3.5 liters, in case of sudden flow interruption.

Response time with 0.4°C and 0.6°C/minute temperature rise with a water flow of 20L/min

°C/min	N°1	N°2	N°3	N°4
0,40	3min 50s	5min 10s	3min 40s	3min 30s
0,60	4min	5min 20s	3min 50s	3min 30s

Response time with 0.4°C and 0.6°C/minute temperature rise with a water flow of 30L/min

°C/min	N°1	N°2	N°3	N°4
0,40	14min 30s	15min 30s	8min 20s	7min 50s
0,60	12min 20s	13min 40 s	9min 40s	9min 10s

Response time with 0.4°C and 0.6°C/minute temperature rise with a water flow of 40L/min

°C/min	N°1	N°2	N°3	N°4
0,40	33min 40s	39min 20s	31min 30s	24min 20s
0,60	30min 40s	32min 20s	26min 30s	22min 20s

Response time at 20 and 30°C/minute temperature rise, as it happens in case of a brutal interruption of flow.

°C/min	N°1	N°2	N°3	N°4
0,40	1min 20s	1min 42s	1 min 12s	1 min 6s
0,60	1min 4s	1min 22s	54 s	51s



F - 4 Thermal response time in dry run conditions upon thermostat surface mounting solution

In some configurations, a disc thermostat mounted on a wall, can detect dry running before the tubular heater deterioration and before a dangerous overheating of the heater walls. Different mounting solutions have been tested. The distance between the sensitive part of the disc thermostat (the cup) and the outer wall of the tubular heater is a critical parameter. Thermal contact is of course the solution that reacts faster, but this configuration is not feasible because it would request that tubular heater touch the tank wall. That's why we developed an extended copper cup which provides direct thermal contact between the heating element and thermostat while allowing proper spacing with the tank wall.

Tank surface temperatures must remain compatible with the type of thermal insulation possibly used, as well as other nearby combustibles materials.

We considered that 800°C was the maximum allowable temperature on the surface of the tubular heater and 150°C the maximum surface temperature allowable on the tank wall.

These values are generally not exceeded when the dry run trip time is less than 2 minutes.

Tests were below was made in the most unfavorable conditions, with a 10W/cm²watt density tubular heater. Thermostats are positioned vertically above it. Disc thermostats are set at an usual temperature for water heaters: 90°C

Distance between tank wall at thermostat place and tubular heater: 0mm (thermal contact)

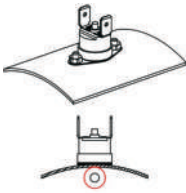
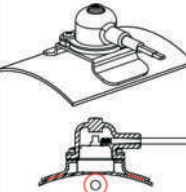
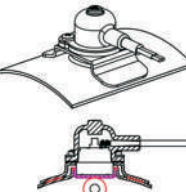
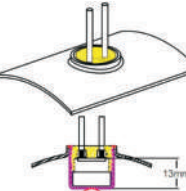
Type	Trip time	Tubular heater surface temperature	Internal surface temperature at disc thermostat place	Tubular heater overshoot temperature	Internal temperature overshoot at disc thermostat place	Comments
 Flat bracket	1:34	687	137	695	162	Average result for all parameters
 Extended cup on flat surface	1:02	517	140	519	176	<p>The best response time, almost a third faster than other solutions, allowing the lowest heater overheating.</p> <p>Overshoot of the thermostat after tripping is compatible with its operation. This solution can be used as dry run safety, but it is technically difficult to implement.</p>
 Flat copper insert	1:34	700	160	705	167	This solution slightly limit the thermostat overheating after tripping because the copper cup dissipate heat
 Extended copper cup	1:28	706	167	707	137	<p>As the temperature sensitive part of the thermostat is away from the wall of the tank, its implementation is possible without contact of the tubular heater with the tank wall. However, the direct thermal contact with the tubular heater limits the use of the thermostat to its application as dry run detection because in normal operation the thermostat detects a water temperature flawed by the surface temperature of the tubular heater. In this case, it is the technical solution with the dry run fastest response time</p>

Because of permanent improvement of our products, drawings, descriptions, features used on these data sheets are for guidance only and can be modified without prior advice

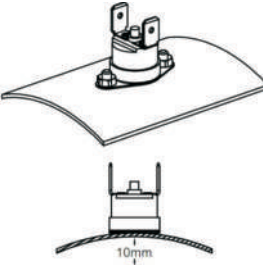
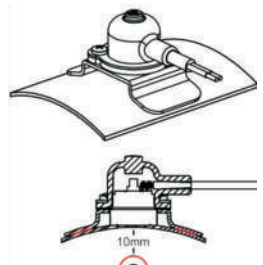
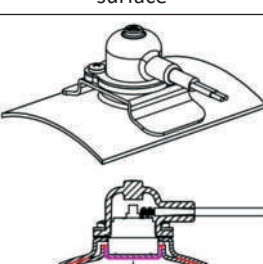
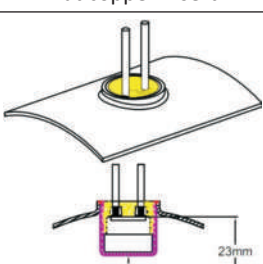

Distance between tank wall at thermostat place and tubular heater: 10mm

Type	Trip time	Tubular heater surface temperature	Internal surface temperature at disc thermostat place	Tubular heater overshoot temperature	Internal temperature overshoot at disc thermostat place	Comments
 <p>Flat bracket</p>	2:00	791	139	791	148	Acceptable results, but the longest heat transfer due to poor contact between the wall and the thermostat increases the response time and overheating that are at the limit
 <p>Extended cup on flat surface</p>	1:56	780	124	780	130	The shortest response time and lowest overheating. This solution is the preferred technical solution for heaters of this catalog, because it can detect both an abnormal rise in the temperature of the water and dry operation, provided that its location is correctly set.
 <p>Flat copper insert</p>	2:12	821	150	821	183	Significant overheating of the tubular heating, which exceeds 800°C.
 <p>Extended copper cup</p>	2:18	794	113	825	180	TLonger response time because the increase in the distance to the wall due to the extended cup limits heat reflection by the wall. Very good heat transfer reduces the tripping temperature but significant overheating of the resistance and the wall.

Because of permanent improvement of our products, drawings, descriptions, features used on these data sheets are for guidance only and can be modified without prior advice

G - Wall mounting solutions for liquid heaters

Apart from some applications of online inlet and outlet heaters held in place by hydraulic connections, it is necessary to hang them on a wall to avoid excessive stresses such as those that may occur during transport or because of the weight of the device. A number of solutions exist.

G - 1 Studs or bolts mounting

Drawing	Feature	Advantages	Disadvantages
	M8 stud	<ul style="list-style-type: none"> - Cheap solution - No important overheat during the condensator discharge welding. - Easy crossing of the thermal insulation - Easy mounting on all heaters diameters 	<ul style="list-style-type: none"> - Hazardous welding strength, very difficult to check - Very large position tolerances - Very larges perpendicularity tolerances
	M8 bolt	<ul style="list-style-type: none"> - The cheapest solution - Easy crossing of the thermal insulation - Easy mounting on all heaters diameters 	<ul style="list-style-type: none"> - The TIG welding on the heater body causes an important overheat of the wall because of huge differences in parts thickness. This induces a corrosion hazard. - Very large position tolerances - Very larges perpendicularity tolerances

G - 2 Precise positioning of brackets and accessories

To ensure accurate positioning of accessories, like wall mounting brackets, thermostats ..., we developed a stamped studs positioning.

Accessories are automatically centered on the studs, whose position is fixed by the deep drawing die of the tank body. No positioning error is then possible.

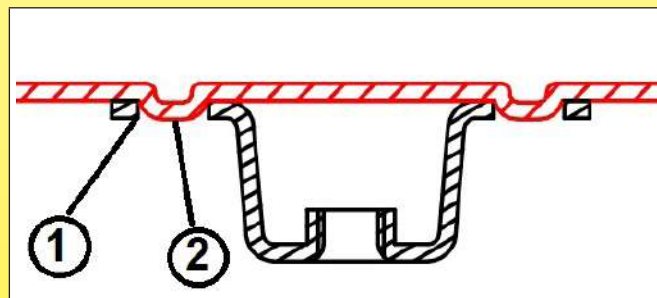

- 1: Positioning holes in the accessory
 2: Studs drawn on the tank wall

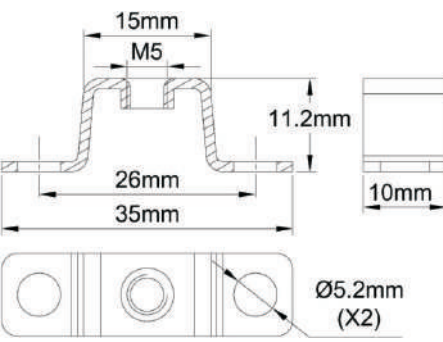
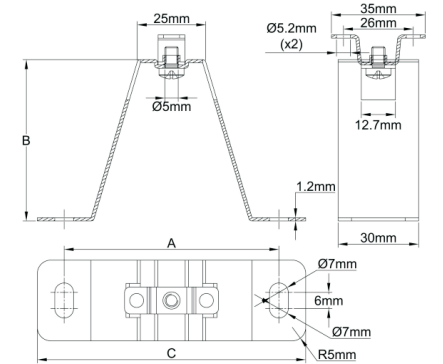
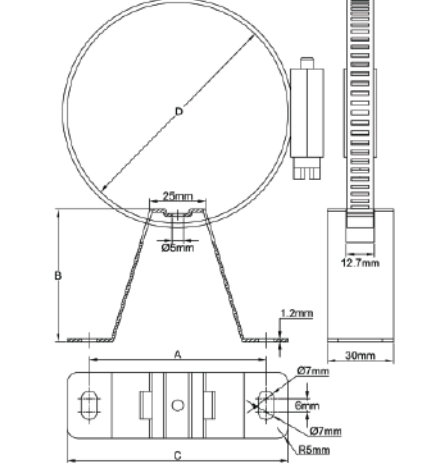
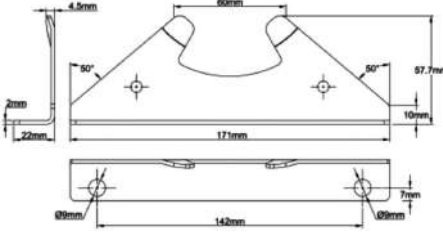

G - 3 Legs mounting

Drawing	Feature	Advantages	Disadvantages
	M5 miniature bracket	<ul style="list-style-type: none"> - Costless and safe - No significant heating during capacitor discharge welding. - Double welding point increase the reliability of the fixing - Easy passage through insulation up to 12mm - Screw mounting through the in the supporting wall - Excellent positioning accuracy by the embossments in the body of the tank - Very low angular positioning tolerances - Enables mounting feet (see below) - Available on all heaters diameters <p style="color: red; font-weight: bold;">This is the recommended solution for heaters of this catalog</p>	- Not really fitted for 20mm thickness insulation
	M5 miniature bracket with legs	<ul style="list-style-type: none"> - No significant heating during capacitor discharge welding. - Double welding point increase the reliability of the fixing - Easy passage through insulation up to 12mm - Excellent positioning accuracy by the embossments in the body of the tank - Very low angular positioning tolerances - Removable feet reducing transportation volume and cost - Available on all heaters diameters 	- Low mechanical strength
	Legs with hose clamp	<ul style="list-style-type: none"> - No welding on the tank - Can be adjusted at any position - Removable feet reducing transportation volume and cost - Available on all heaters diameters 	<ul style="list-style-type: none"> - Not recommended on heaters with insulation foam - Hose clamp is expensive in large diameters
	Plain legs welded on flanges	<ul style="list-style-type: none"> - No significant heating during capacitor discharge welding. - Double welding point increase the reliability of the fixing - High mechanical strength - Available on all heaters diameters - Can be used with any insulation thickness 	<ul style="list-style-type: none"> - No possible adjustment - Costly

Because of permanent improvement of our products, drawings, descriptions, features used on these data sheets are for guidance only and can be modified without prior advice



H: Wiring design rules

H - 1 Terminals protection after end sealing

Type	Features	Advantages	Disadvantages
	<p>Standard M4 terminal</p> <p>1: Insulation against moisture ingress.</p> <p>2: Ceramic insulator provides mechanical strength, centering, and compliance with air and tracking distance requested by standards.</p> <p>3: Tank wall</p> <p>4: TIG welding between tank wall and heater tube</p>	<p>Upon EN 60335-1, annex M, the 5mm distance, standard in all heaters of this catalogue, allows to use these terminals on the following pollution degrees:</p> <p>250V: Pollution degree 4 (The pollution generates persistent conductivity caused by conductive dust or by rain or snow.)</p> <p>400V: Pollution degree 3 (Conductive pollution occurs or dry non-conductive pollution occurs which becomes conductive due to condensation which is to be expected.)</p>	<ul style="list-style-type: none"> - No protection against accidental contact - 5mm length must be strictly respected after terminal wiring - No protection against water ingress
	<p>Standard M4 terminal for highly polluted micro-environments..</p> <p>1: Insulation against moisture ingress.</p> <p>2: Ceramic insulator provides mechanical strength, centering, and compliance with air and tracking distance requested by standards.</p> <p>3: Tank wall</p> <p>4: TIG welding between tank wall and heater tube</p>	<p>Upon EN 60335-1, annex M, the 9mm distance (1mm longer than requested by standard), available on request on all heaters of this catalogue, allows to use these terminals on the pollution degree 4 in 250 and 400V. (The pollution generates persistent conductivity caused by conductive dust or by rain or snow.)</p>	<ul style="list-style-type: none"> - No protection against accidental contact - 5mm length must be strictly respected after terminal wiring - No protection against water ingress
	<p>Terminal with spot welded wire, protected by dual layer shrinkable tube. Melting internal layer.</p>	<ul style="list-style-type: none"> - Water drip ingress rough protection - Protects against accidental contacts - Cheap solution 	<ul style="list-style-type: none"> - Do not provide any additional protection against moisture. resistance of the heating elements - Straight output only. - Breaking of spot welding, which is the critical point of this assembly can cause a short circuit. - Unsecured protection against water ingress
	<p>Silicone boot on terminal and wire.</p>	<ul style="list-style-type: none"> - Easy installation. - Provides an IP44 to IP54 water ingress protection (upon models) - Mainly used as protection against accidental contacts - Exists for M4 screw terminals, 6.3 Quick connect terminals and vertical wire weld terminals 	<ul style="list-style-type: none"> - Do not provide any additional protection against moisture.
	<p>Silicone boot on terminal and wire, resin potted.</p>	<ul style="list-style-type: none"> - Reduces generally the moisture absorption rate of the heating element. - Allows to reach an IP66 sealing. 	<ul style="list-style-type: none"> - Available only on side outlet terminals. - Factory assembly only.
	<p>All tubular heaters connections fully potted together with epoxy, wires or cable output.</p>	<ul style="list-style-type: none"> - Ensures IP67 sealing - Divides by 10 the moisture absorption rate of all heating elements - In devices having 3 and more heating elements, this solution is less expensive than individual heating elements sealing 	<ul style="list-style-type: none"> - Factory assembly only.
	<p>All tubular heaters connections fully potted together with epoxy, on built in connection block.</p>	<ul style="list-style-type: none"> - Ensures IP67 sealing, connection block excluded. - IP44 cover with M20 cable gland available for connection block - Divides by 10 the moisture absorption rate of all heating elements - Allows a standardization of heaters, independent of wiring and cables 	<ul style="list-style-type: none"> - Factory assembly only

Because of permanent improvement of our products, drawings, descriptions, features used on these data sheets are for guidance only and can be modified without prior advice

H - 2 Terminals temperature rise vs protection and power

The terminals of the heating elements are heated by the Joule effect by the current flowing through them. The resistance of these terminals depends on the electrical resistivity of the metal used, the current intensity, and inversely proportional to the cross section.

Resistivity table of the of the most common materials used in the manufacture of tubular heaters terminals

Material	Pure copper	63% copper brass	Pure Nickel	Steel	304SS
Resistivity ρ (Ohm*mm ² /m)	0,017	0,067	0,087	0,1	0,73

Comparative values of the resistance in milliohms of different types of terminals according to their material (Calculated for a length of 20mm)

Terminal style	Material				
	Pure copper	63% copper brass	Pure Nickel	Steel	304SS
M4 screw (dia. 3.3mm cross section)	0,040	0,157	0,20	0,234	1,7
Dia. 3mm rod	0,048	0,190	0,25	0,283	2,1
M3 screw (2.5mm cross section)	0,069	0,273	0,35	0,408	3,0
6.35 x 0.8mm fast-on terminal	0,067	0,266	0,35	0,397	2,9
Dia. 2mm rod	0,108	0,427	0,55	0,637	4,6

Comparative value of the dissipated power with a 16Amps intensity (Watts)

Terminal style	Material				
	Pure copper	63% copper brass	Pure Nickel	Steel	304SS
M4 screw (dia. 3.3mm cross section)	0,010	0,040	0,052	0,060	0,437
Dia. 3mm rod	0,012	0,049	0,063	0,072	0,529
M3 screw (2.5mm cross section)	0,018	0,070	0,091	0,104	0,762
6.35 x 0.8mm fast-on terminal	0,017	0,068	0,088	0,102	0,742
Dia. 2mm rod	0,028	0,109	0,142	0,163	1,190

The largest temperature rises are those of stainless steel terminals. This metal being for other technical reasons the one selected as the standard for the construction of the heaters, we measured the terminals self-heating in the most common cases.

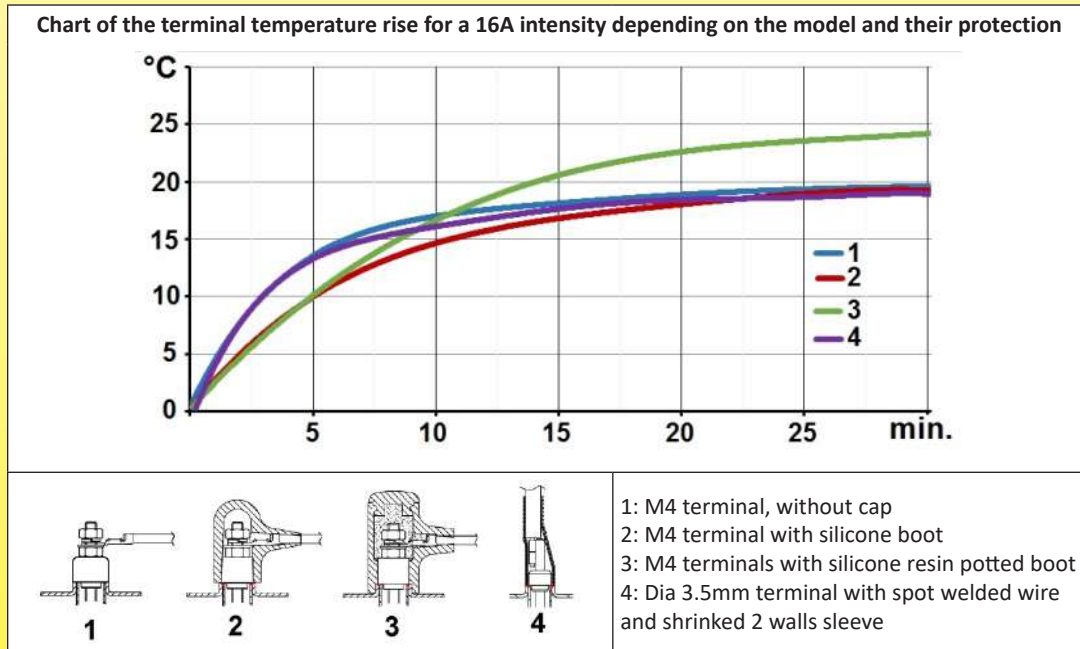

H - 3 Heating elements configurations upon the operating voltage

The heaters can be equipped from one to 6 tubular heaters. The number of them depends on the requested power, number of phase of the power supply, and the number of power stages needed by the temperature regulating system. The number of heating elements is also limited by the size of the heater.

Typically, less than 3500Watts systems can be supplied with 230 Volt single phase, and the higher power ratings, preferably with a three-phase 400 Volt.



Because of permanent improvement of our products, drawings, descriptions, features used on these data sheets are for guidance only and can be modified without prior advice

H - 4 Main wiring diagrams

	<p><u>Only one heating element, 230V power supply</u></p>
	<p><u>Two heating element, 230V power supply (circuit1):</u> This allows a one or two power stages (or three power stages if R1 and R2 are different), but the connection 400V is impossible. It can be connected in serial for use in 115V (circuit 2)</p>
	<p><u>3 heaters, wired in 230 volts:</u> This arrangement allows single phase 230V wiring with 1, 2 or 3 power stages with heating elements connected in parallel (circuit 1) and a 400V three-phase power supply, but only with a single power stage in connecting the star (circuit 2).</p>
	<p><u>3 heaters, wired in 400 volts:</u> This arrangement does not allow a 230V single phase power supply of but allows two power stages, by switching from star wiring (circuit 1) to triangle (circuit 2).</p>
	<p><u>6 heaters, wired in 230V:</u> This arrangement allows a single phase 230V connection with up to 6 power stages with a parallel connection (circuit 1) and a three-phase 400V connection with one or two power stages by star wiring (circuit 2).</p>



H - 5 Mounting possibilities of heating elements depending on the size of the tank and the supply voltage

230V single phase		400V, 3 phase		230V single phase with commutation to 400V 3 phase	
Only one power stage	Two power stages	Only one power stage	Two power stages	Only one power stage	Two power stages
Only one tubular heater	Two tubular heaters	3 tubular heaters	6 tubular heaters.	3 tubular heaters wired in 230V	6 tubular heaters wired in 230V
Tank dia. from 70 to 140mm	Tank dia. from 76 to 140mm	Tank dia. from 76 to 140mm	Tank dia. 125 or 140mm	Tank dia. from 76 to 140mm	Tank dia. 125 or 140mm

H - 6 Wires comparison

When used in heaters of this catalogue, cables must meet specific constraints, they are:

- **An insulation class matching the supply voltage:** UL hook up wires are divided into 300V and 600V classes. Voltages are measured between the core conductor and earth).

In the harmonized European standards (HAR) wire nominal voltage is given by (U₀/U) where U₀ is the rms voltage measured between the core conductor and the earth, and U the rms value between two conductors). For heaters in this catalog, the most common voltage is the class 05 (300-500V), but the class 07 (450-750V) can also be used.

NB: The rated voltage of the cable must be at least equal to the nominal voltage of the installation.

- **Temperature résistance:** Depending on the type of insulation selected, the maximum temperature may range from 70°C (standard PVC) to 200°C (FEP) or event to 250°C (high temperature silicone). This parameter is important for resistance to ignition and flammability tests, but also because a cable with a high holding temperature admits a greater intensity for the same gauge.

- **Insulation resistance to accidental piercing (abrasion resistance):** Silicone is fragile, the insulation can be pierced by nails or hits during handling and incorporation, then it may be necessary to choose cables with an additional protection braid like H05SS-K. This increases the size of the wiring harness, but also the cost. FEP and ETFE have the best resistance to accidental insulation piercing.

- **Cables outside diameter:** It is the result the thickness of insulation needed to meet the insulation standards corresponding to the power supply voltage. FEP and ETFE have very low thicknesses, allowing more compact wiring. Silicone and PVC, less efficient electrical insulators, may request wall thicknesses up to more than 3 times greater.

- **The potting resins ability to bond to cables:** Combinations of the different wires insulating materials and potting resins are not all effective, and some do not provide any protection against water ingress.

PVC and XLPE have the best bonding with epoxy, and silicone bonds correctly only on silicone resins.

- **Fire behaviour, halogens:**

When applications request a good fire resistance, and halogen free, only XPLE and silicone can be used

H - 7 Insulation materials tensile strength

(Considered as an indicator of the sensitivity to accidental cut of insulation layer)

Silicone (Standard: EN-50525-2-41)	PVC (Standard: EN-50525-2-11)	XLPE Cross linked polyethylene	FEP Fluorinated ethylene propylene	ETFE Ethylene tetrafluoroethylene
4 N/mm ²	10 N/mm ²	18 N/mm ²	23 N/mm ²	42 N/mm ²



H - 8 Wires pull strength vs potting material and wire insulation material

In the technical solutions of sealing wires by potting, it is important that the bonding between the wire insulation and the potting resin is effective to avoid water ingress.

Some standards also request a minimum value for cables en wires pull test

We therefore conducted tests between different kinds of wires insulation and resins to define the best solutions. The wires have been degreased before filling without any other surface treatment. Potting thickness is 5mm. Average values measured on 5 samples for each combination.

Resins	PVC insulated wires	Silicone insulated wires	Cross linked polyethylene insulated wires	FEP insulated wires
Silicone#1	0.88 DaN	0.88 DaN	1.56	0.21 DaN
Silicone#2	0.26 DaN	0.58 DaN	0.2	0.32 DaN
Silicone#3	3.3 DaN	2.18 DaN	6.7	0.21 DaN
Silicone#4	0.22 DaN	1.40 DaN	1.62	0.13 DaN
Epoxy#1	8.74 DaN *	1.46 DaN	13.0	1.36 DaN
Epoxy#2	8.96 DaN *	1.32 DaN	9.22	1.52 DaN
Epoxy#3	8.84 DaN *	1.42 DaN	8.98 DaN	2.14 DaN
Epoxy#4	7.42 DaN	1.26 DaN	10.74 DaN	1.80 DaN
Epoxy#5	7.52 DaN	1.14 DaN	8.48 DaN	1.60 DaN
	Poor	Low	Good	Outstanding

The values are highly variable upon combinations, with ratios from 1 to 40.

- The pull-out strength PVC wire is fair or poor with most silicone resins, but excellent with all epoxy resins
- The pull-out strength of silicone insulated wires can be very good, fair or poor, depending on the silicone resin used, but it is average in all cases with all the epoxy resins.
- The pull-out strength of the cross linked polyethylene insulated wires **is the best in all combinations.**
- The pull-out strength of the FEP insulated wires is bad with all silicone resins, and average to good with epoxy resins.

*: The breakage of the insulation of the wire or wire occurred at this value, outside the resin filling

H - 9 Comparison of hook up wires insulation thickness (average values in mm)

Insulation material	300V (HAR= H05....)	450V (HAR= H07...)	300V (UL)	600V (UL)
FEP (ETFE) section <1.5mm ² (AWG15)	0.30		0.33	0.51
FEP (ETFE) section ≥1.5mm ² (AWG15)	0.35		0.33	0.51
XLPE (UL3266), section <AWG14)			0.4	
XLPE (UL3266), section AWG14~AWG10			0.5	
XLPE (UL3271)				0.79
PVC (H05V-K) ≤1mm ²	0.6			
PVC (H07V-K) ≤1.5mm ²		0.7		
PVC (UL1007= 300V, UL1015= 600V)			0.4	0.79
PVC (H07V-K) >1.5mm ² , <10mm ²		0.8		
Silicone H05S-K), ≤1.5mm ²	0.8			
Silicone H05S-K, 1.5mm ²	0.9			
Silicone H05S-K, 2.5mm ²	1			
Silicone UL3212 (600V, -50+150°C)				1.14
Silicone UL3251 (600V, -50+250°C)				1.2



H-10 Comparison of stranded wires used in internal wiring of equipment

AWG	Equivalent in mm ²	Standard	Insulation	Composition (Qty and diameter)	Outside diameter	Temperature range	Rated voltage
22	0.33	UL1330	FEP	19 × 0.15	1.8	-80+200	600V
20	0.5	UL1330	FEP	19 × 0.19	2	-80+200	600V
18	0.8	UL1330	FEP	19 × 0.235	2.3	-80+200	600V
17	1.02	UL1330	FEP	19 × 0.26	2.38	-80+200	600V
16	1.30	UL1330	FEP	19 × 0.30	2.6	-80+200	600V
15	1.53	UL1330	FEP	19 × 0.32	2.7	-80+200	600V
13	2.5	UL1330	FEP	19 × 0.41	3.13	-80+200	600V
12	3.31	UL1330	FEP	19 × 0.48	3.52	-80+200	600V
22	0.33	UL1331	ETFE	19 × 0.15	1.8	-80+150	600V
20	0.5	UL1331	ETFE	19 × 0.19	2	-80+150	600V
18	0.8	UL1331	ETFE	19 × 0.235	2.3	-80+150	600V
17	1.02	UL1331	ETFE	19 × 0.26	2.38	-80+150	600V
16	1.30	UL1331	ETFE	19 × 0.30	2.6	-80+150	600V
15	1.53	UL1331	ETFE	19 × 0.32	2.7	-80+150	600V
13	2.5	UL1331	ETFE	19 × 0.41	3.13	-80+150	600V
12	3.31	UL1331	ETFE	19 × 0.48	3.52	-80+150	600V
22	0.33	UL1332	FEP	19 × 0.15	1.45	-80+200	300V
20	0.5	UL1332	FEP	19 × 0.19	1.65	-80+200	300V
18	0.8	UL1332	FEP	19 × 0.235	1.87	-80+200	300V
17	1.02	UL1332	FEP	19 × 0.26	2.08	-80+200	300V
16	1.30	UL1332	FEP	19 × 0.30	2.25	-80+200	300V
15	1.53	UL1332	FEP	19 × 0.32	2.35	-80+200	300V
13	2.5	UL1332	FEP	19 × 0.41	2.8	-80+200	300V
12	3.31	UL1332	FEP	19 × 0.48	3.2	-80+200	300V
22	0.33	UL1333	ETFE	19 × 0.15	1.45	-60+150	300V
20	0.5	UL1333	ETFE	19 × 0.19	1.65	-60+150	300V
18	0.8	UL1333	ETFE	19 × 0.235	1.87	-60+150	300V
17	1.02	UL1333	ETFE	19 × 0.26	2.08	-60+150	300V
16	1.30	UL1333	ETFE	19 × 0.30	2.25	-60+150	300V
15	1.53	UL1333	ETFE	19 × 0.32	2.35	-60+150	300V
13	2.5	UL1333	ETFE	19 × 0.41	2.8	-60+150	300V
12	3.31	UL1333	ETFE	19 × 0.48	3.2	-60+150	300V
(20)	0.5	VDE7673	FEP	19 × 0.185	1.59	-80+180	300V
(18)	0.75	VDE7673	FEP	19 × 0.23	1.82	-80+180	300V
(17)	1	VDE7673	FEP	19 × 0.26	1.96	-80+180	300V
(15)	1.5	VDE7673	FEP	19 × 0.32	2.15	-80+180	300V
(13)	2.5	VDE7673	FEP	19 × 0.40	2.73	-80+180	300V
(11)	4	VDE7673	FEP	37 × 0.375	3.4	-80+180	300V
22	0.33	UL3266	XLPE	17 × 0.16	1.56	-40+125°C	300V
20	0.5	UL3266	XLPE	26 × 0.16	1.75	-40+125°C	300V
18	0.8	UL3266	XLPE	16 × 0.254	1.98	-40+125°C	300V
16	1.30	UL3266	XLPE	26 × 0.254	2.30	-40+125°C	300V
14	2	UL3266	XLPE	41 × 0.254	2.88	-40+125°C	300V
12	3.31	UL3266	XLPE	65 × 0.254	3.37	-40+125°C	300V
22	0.33	UL3271	XLPE	17 × 0.16	2.35	-40+125°C	600V
20	0.5	UL3271	XLPE	26 × 0.16	2.55	-40+125°C	600V
18	0.8	UL3271	XLPE	16 × 0.254	2.75	-40+125°C	600V
16	1.30	UL3271	XLPE	26 × 0.254	3.10	-40+125°C	600V
14	2	UL3271	XLPE	41 × 0.254	3.50	-40+125°C	600V
12	3.31	UL3271	XLPE	65 × 0.254	3.95	-40+125°C	600V
(20)	0.5	H05V-K	PVC	16 × 0.2	2.2	-40+70 (90)	300/500V
(18)	0.75	H05V-K	PVC	24 × 0.2	2.4	-40+70 (90)	300/500V
(17)	1	H05V-K	PVC	32 × 0.2	2.5	-40+70 (90)	300/500V
(15)	1.5	H07V-K	PVC	30 × 0.25	3.1	-40+70 (90)	450/750V
(13)	2.5	H07V-K	PVC	49 × 0.25	3.7	-40+70 (90)	450/750V
(11)	4	H07V-K	PVC	56 × 0.3	4.4	-40+70 (90)	450/750V
22	0.33	UL1015	PVC	17 × 0.16	2.35	-40+105	600V
20	0.5	UL1015	PVC	26 × 0.16	2.55	-40+105	600V
18	0.8	UL1015	PVC	16 × 0.254	2.75	-40+105	600V
16	1.30	UL1015	PVC	26 × 0.254	3.10	-40+105	600V
14	2	UL1015	PVC	41 × 0.254	3.50	-40+105	600V
12	3.31	UL1015	PVC	65 × 0.254	3.95	-40+105	600V
22	0.33	UL1007	PVC	41 × 0.254	1.6	-40+105	300V
20	0.5	UL1007	PVC	65 × 0.254	1.8	-40+105	300V
18	0.8	UL1007	PVC	41 × 0.254	2.1	-40+105	300V
16	1.30	UL1007	PVC	65 × 0.254	2.4	-40+105	300V
14	2	UL1007	PVC	41 × 0.254	2.7	-40+105	300V
12	3.31	UL1007	PVC	65 × 0.254	3.3	-40+105	300V
(20)	0.5	H05S-K	Silicone	20 × 0.18	2.52	-50+180	300/500V
(18)	0.75	H05S-K	Silicone	30 × 0.18	2.73	-50+180	300/500V
(17)	1	H05S-K	Silicone	40 × 0.18	2.91	-50+180	300/500V
(15)	1.5	H05S-K	Silicone	30 × 0.254	3.40	-50+180	300/500V
(13)	2.5	H05S-K	Silicone	50 × 0.254	4.16	-50+180	300/500V

Because of permanent improvement of our products, drawings, descriptions, features used on these data sheets are for guidance only and can be modified without prior advice



Because of permanent improvement of our products, drawings, descriptions, features used on these data sheets are for guidance only and can be modified without prior advice

AWG	Equivalent in mm ²	Standard	Insulation	Composition (Qty and diameter)	Outside diameter	Temperature range	Rated voltage
22	0.33	UL3212	Silicone	41 × 0.254	3.1	-50+150	600V
20	0.5	UL3212	Silicone	65 × 0.254	3.3	-50+150	600V
18	0.8	UL3212	Silicone	41 × 0.254	3.5	-50+150	600V
16	1.30	UL3212	Silicone	65 × 0.254	3.8	-50+150	600V
14	2	UL3212	Silicone	41 × 0.254	4.2	-50+150	600V
12	3.31	UL3212	Silicone	65 × 0.254	4.6	-50+150	600V
22	0.33	UL3251	Silicone	41 × 0.254	3.1	-50+250	600V
20	0.5	UL3251	Silicone	65 × 0.254	3.3	-50+250	600V
18	0.8	UL3251	Silicone	41 × 0.254	3.5	-50+250	600V
16	1.30	UL3251	Silicone	65 × 0.254	3.8	-50+250	600V
14	2	UL3251	Silicone	41 × 0.254	4.2	-50+250	600V
12	3.31	UL3251	Silicone	65 × 0.254	4.6	-50+250	600V

H - 11 Relative price comparison to H07-VK (1.5mm² wires*)

Insulation	PVC* (H05V-K 70°)	PVC (H07V-K 70°)	Silicone (H05S-K)	XLPE 300V (UL3398, 150°)	ETFE 300V (VDE 7994)	FEP 300V (VDE 7623)	FEP 600V (VDE7997)
Ratio	(0.93)	1	1.33	1.34	2.30	2,62	3,20

*H05V-K is not produced for gauges higher than 1mm².



H - 12 Zero halogen and flame retardant cables and wires insulation.

- Two halogens, chlorine and fluorine, are extensively used in compounds for insulating electrical wire. Halogenated compounds are normally very stable. When they burn, however, the halogens separate and become highly reactive, forming very toxic, extremely dangerous and corrosive gasses that can significantly damage organic, inorganic and metallic materials, animals and humans.

- Additives are added to these plastics to prevent, delay or limit their ignition. They are regulated by two different set of standards: Those that govern the design of the components in electrical equipment, to prevent them catching fire (Self-extinguishing) and those that govern the design of the products used in the building or transportation to delay the spread of fire (flame retardants).

Note: Halogen being excellent additives in plastics to make them self-extinguishing, some cables made with halogen-free materials (XLPE, Silicone) can have a significant content of them in low price self-extinguishing versions.

Standards	PVC	XLPE	Silicone	ETFE (Tefzel)	FEP
Self-extinguishing (UL94)	UL94-V0 without need of additives	UL94-V0 (Some UL94-V0 grades may contain 7 to 17% of halogenated flame retardant)	UL94-HB to HL94-V0 (Some UL94-V0 grades may contain 7 to 17% of halogenated flame retardant)	UL94-V0 without need of additives	UL94-V0 without need of additives
Flame retardant (UL1581-section 1080) (Equivalent to IEC 60332-1-2)	UL VW-1	UL VW-1	UL VW-1 + High ignition point + In case of fire forms an insulating layer SiO ₂	UL VW-1	UL VW-1
Halogen free (IEC 60754)	22 to 29% Chlorine	Halogen free if right additives used	Halogen free if right additives used	59% Fluorine	62~78% Fluorine

UL 94, Flammability of Plastic Materials for Parts in Devices and Appliances.

The standard classifies plastics according to how they burn in various orientations and thicknesses. From lowest (least flame-retardant) to highest (most flame-retardant), the classifications are:

HB: slow burning on a horizontal specimen; burning rate <76mm/min for thickness <3mm and burning stops before 100mm

V-2 burning stops within 30 seconds on a vertical specimen; drips of flaming particles are allowed.

V-1: burning stops within 30 seconds on a vertical specimen; drips of particles allowed as long as they are not inflamed.

V-0: burning stops within 10 seconds on a vertical specimen; drips of particles allowed as long as they are not inflamed.

5VB: burning stops within 60 seconds on a vertical specimen; no drips allowed; plaque specimens may develop a hole.

5VA: burning stops within 60 seconds on a vertical specimen; no drips allowed; plaque specimens may not develop a hole

VW-1 Vertical-Wire Flame Test (UL 1581)

This is a small-scale test conducted on a single 24-inch length of wire. The flame source is a Bunsen burner. The flame is applied for 15 seconds and is then reapplied 4 more times each time the wire ceases to burn. If the sample burns longer than 60 seconds after any application, or if the paper indicator flag or cotton batting is ignited during the test, the cable fails the test. The CSA (Canadian Standards Association) FT-1 test is very similar.

IEC 60754 Tests On Gases Evolved During Combustion Of Materials From Cables

Part 1: Determination of amount of halogen acid gas (Determines the level of halogen emission of the materials used in the cable)

– Halogen acid evolved after 60 minutes burn time is captured, absorbed into a test solution and expressed as an amount of hydrochloric or hydrofluoric acid.

The level of hydrochloric or hydrofluoric acid measured in the test solution must be less than **5 mg/g**.

Part 2: Determination of degree of acidity of gases for materials by measuring pH and conductivity.

– Gases produced after 30 minutes burn time are captured, absorbed into a test solution and analysed for pH and conductivity.

The pH value of the test solution should not be less than **4.3**.

The conductivity value of the test solution should not exceed 10 µS/mm.

For a cable to be classified as halogen free, it must pass both parts of IEC 60754.

Note: Other similar standard can be used for testing halogen in cables, like NF C 32-070, test C1.

IEC 61034-2 Measurement of smoke density of cables burning under defined conditions.

A minimum light transmission value, expressed as a percentage light transmittance, is recorded during a fire in a 3 m³ area.

The recommended minimum light transmission value is greater than 60%.

Note: NF C 32-073 is equivalent to IEC 61034-2.

Because of permanent improvement of our products, drawings, descriptions, features used on these data sheets are for guidance only and can be modified without prior advice



Because of permanent improvement of our products, drawings, descriptions, features used on these data sheets are for guidance only and can be modified without prior advice

H - 13 Temperature rise of an electrical wire vs electrical intensity and ambient temperature.

According to the International Electrotechnical Commission, the (continuous) current-carrying capacity, (Ampacity in US) “is the maximum value of electric current which can be carried continuously by a conductor, a device or an apparatus, under specified conditions without its steady-state temperature exceeding a specified value”. (IEV-826-11-13).

The specified value is the maximum temperature printed on wires insulation or specified on their data sheets.

In the internal wiring of appliances, the temperature the wire will reach is the result of its self-heating by Joule effect, the internal temperature of the device where the driver is located, and cooling due to eventual convection currents.

The maximum acceptable internal temperature of the finished equipment is a parameter determined by the integrator, usually based on Standards requirements.

The wire gauge and its type of insulation choice will be the consequences of this maximum allowable temperature.

The informational table below gives the overheating of single wires depending on the intensity, the gauge, the insulation style and ambient temperature. It is intended to be a preliminary selection guide. When the cables are wired in beams, intensity reduction coefficients must be applied. It is possible for it to use those recommended by EN60204-1 (1998) standard, for installation type E:

Amps reduction coefficient based on the number of circuits with load			
2	4	6	9
0.88	0.77	0.73	0.72

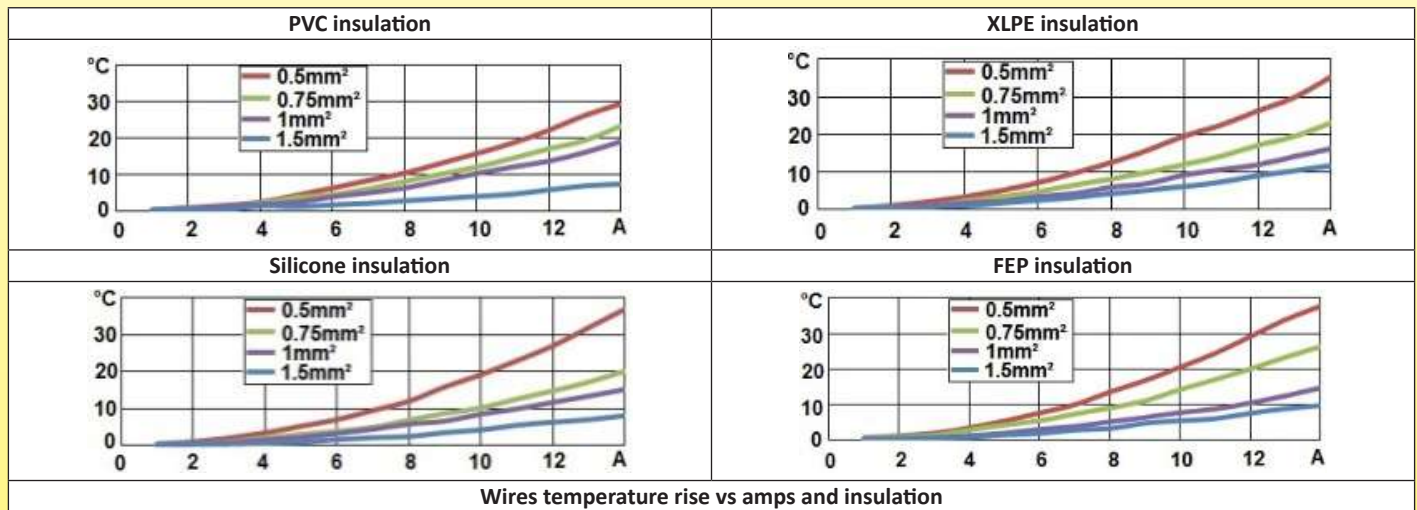

H - 14 Earthing rules requested by standards

There are many normative obligations regarding earthing devices. They all aim to ensure the safety of people. The most important of them, extracted from the EN60335-1 standard are:

- 1-All parts of the earthing terminal intended for the connection of external conductors shall be such that there is no risk of corrosion resulting from contact between these parts and the copper of the earthing conductor or any other metal in contact with these parts. Parts providing earthing continuity, shall be of metal having adequate resistance to corrosion. If these parts are of steel, they shall be provided at the essential areas with an electroplated coating having a thickness of at least 5 microns. Parts of copper or copper alloys containing at least 58% copper for parts that are worked cold, and at least 50% copper for other parts, and parts of stainless steel containing at least 13% chrome are considered to be sufficiently resistant to corrosion.
- 2-The voltage drop between the earthing terminal of the appliance or the earthing contact of the appliance inlet and the accessible metal part is measured. The resistance calculated from the current and this voltage drop shall not exceed 0.1 Ohm.
- 3-Thread-cutting (self-tapping) screws and thread rolling screws shall only be used for electrical connections if they generate a full form standard machine screw thread. However, thread-cutting (self-tapping) screws shall not be used if they are likely to be operated by the user or installer.
- 4-At least two screws must be used for each connection providing earthing continuity unless the screw forms a thread having a length of at least half the diameter of the screw.
- 5-Screws and nuts shall be secured against loosening if they make electrical connections or connections providing earthing continuity. Spring washers, lock washers and crown type locks as part of the screw head are means that may provide satisfactory security
- 6-Terminals for the connection of external equipotential bonding conductors shall allow the connection of conductors having nominal cross-sectional areas of 2.5mm² to 6mm² and shall not be used to provide earthing continuity between different parts of the appliance. It shall not be possible to loosen the conductors without the aid of a tool.
- 7-Electrical connections and connections providing earthing continuity shall be constructed so that contact pressure is not transmitted through insulating material that is liable to shrink or to distort unless there is sufficient resiliency in the metallic parts to compensate for any possible shrinkage or distortion of the insulating material. Ceramic material is not liable to shrink or to distort.

H - 15 Earthing terminals of heaters

All earthing terminals are in stainless steel and were designed to meet the specifications above. In particular, they are provided with stainless steel screws and spring washers, and have a sufficient thread length. To ensure additional safety conditions, logically deduced from the spirit of the standard, the fixing by spot welds has at least two distinct and separate points. Earthing screws tightening torques: M4: 1.2 Nm, M5: 2 Nm.

Type							
Thread	M4	M4	M4	M5	M5	M5	
Fixing	2 spot welds	2 spot welds	2 spot welds	2 spot welds	3 spot welds	3 spot welds	
Features	Can be used for earthing or for wall mounting. 11mm height allows its use with 10mm thickness insulation foam. Mounting on flat part of tank. It has 2 holes for precise positioning on protruding studs. Can be used on all tanks diameters.	Can be used for earthing or for wall mounting. 7mm height allows its use with 5 or 6mm thickness insulation foam. Mounting on flat part of tank. It has 2 holes for precise positioning on protruding studs. Can be used on all tanks diameters.	Can be used for earthing or for wall mounting. 7mm height allows its use with 5 or 6mm thickness insulation foam. Mounting on flat part of tank. It has 2 holes for precise positioning on protruding studs. Can be used on all tanks diameters.	Can be used for earthing or for wall mounting. 7mm height allows its use with 5 or 6mm thickness insulation foam. Mounting on flat part of tank. It has 2 holes for precise positioning on protruding studs. Can be used on all tanks diameters.	Can be used for earthing or for wall mounting. 7mm height allows its use with 5 or 6mm thickness insulation foam. Mounting on flat part of tank. It has 2 holes for precise positioning on protruding studs. Can be used on all tanks diameters.	It has a hook and a M5 thread for mounting stainless steel mechanical protection cover on heating elements terminals. Must be mounted on the flange with tubular heaters output. Can be used on dia 100, 125 and 150mm.	It has a hook and a M5 thread for mounting stainless steel mechanical protection cover on heating elements terminals. Must be mounted on the flange with tubular heaters output. It has 2 holes for precise positioning on protruding studs. Can be used on dia 100, 125 and 150mm.
Terminal resistance, measured under screw head	1.3 milliohms	0.7 milliohms	1.2 milliohms	0.6 milliohms	0.4 milliohms	0.4 milliohms	

H - 16 Cover for wiring mechanical protection

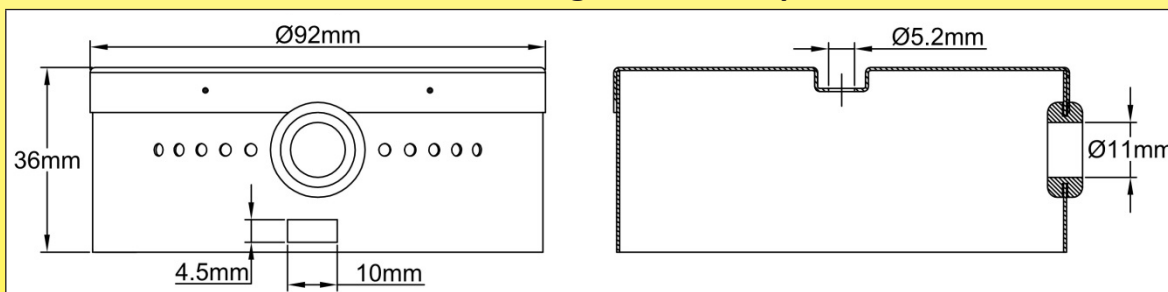

To protect the electrical terminals against shocks, a stainless steel cover may optionally be mounted on the output flange. It is fixed by a screw and a hook in the ground terminal. It does not provide protection against water drops.

I - Control and safety devices

I - 1 Electronic temperature controllers, thermostats, temperature limiters, thermal cutouts

These components serve different functions, and provide additional safety levels.

Their combinations are multiple and usually left to the choice of the integrator, as well as their set points.

Their positioning inside the heaters of this catalogue, is decided, by testing in the most adverse conditions to provide the best reaction.

	<p><u>- Electronic temperature controllers:</u> They are intended to control the temperature of liquid flowing in the heating loop. The point where they measure the temperature is usually located near the liquid outlet after reheating or sometimes in a location of the circuit located outside the heater. They can control the heating in one, two, or sometimes three power stage. They are sometimes equipped with a high temperature alarm. These components are usually not incorporated into the body of the heater, but a pocket is usually provided for mounting the temperature sensor</p>
	<p><u>- Adjustable bulb and capillary thermostats:</u> They are intended to control the temperature of liquid circulating in the heating loop. The place where they sense the temperature is usually located near the liquid outlet. They have no specific action if for some reason the temperature they control is exceeded due to failure of the unit. These components can be on request incorporated into the connection box of the heater, and a pocket is usually provided for mounting their bulb. In domestic appliances applications like storage water heaters, the thermostat is usually set so that the temperature of the water inside the tank is around 60°C, to reduce the risk of limestone deposit, and burn wounds, and in drinking water applications, to avoid bacteriological development (legionella). For domestic water heaters, the maximum set temperature cannot exceed 80°C.</p>
	<p><u>Disc thermostat temperature limiters:</u> They are intended to detect a high liquid temperature in the heater. Therefore they are positioned at the top, but where it is not likely to be an air pocket. They are mounted on the external wall of the tank. They will trig at a factory preset value, in response to a temperature increase of the wall. They will automatically reset when temperature drop. We recommend protecting these thermostats against water ingress by a silicone cap or an epoxy potting, that also prevent accidental hand contact with live terminals. In devices of this catalog, we favor thermostats with cables soldered to the terminals, allowing to achieve a good seal.</p>
	<p><u>Disc thermostat manual reset temperature limiters:</u> They are intended to detect an abnormal high liquid temperature in the heater. Therefore, like the automatic reset models, they are positioned at the top, where it is not likely to be an air pocket. They are mounted on the external wall of the tank. They will trig at a preset value, in response to an abnormal temperature increase when the flow decrease or stop, and when the temperature control device has failed. They are usually single pole but 2 poles and 3 poles exist. When triggered, it is possible to reset the using a button located between the two electrical terminals. Access to this button must be protected, because it is possible to touch live terminal with finger. We recommend protecting these thermostats against water ingress by a silicone cap or an epoxy potting, that also prevent accidental hand contact with live terminals. Silicone caps that we have developed allow manual reset without need to remove them. In devices of this catalog, we favor thermostats with cables soldered to the terminals, allowing to achieve a good seal.</p>
	<p><u>- Bulb and capillary temperature limiters:</u> They are intended to detect an abnormal high liquid temperature in the heater. Therefore they are positioned at the top, but where it is not likely to be an air pocket. Their sensor must be mounted in a pocket. The electrical body can be mounted inside the connection box. They have only a manual reset action. They are fail-safe, this means that they will trig if their bulb or capillary leaks or is broken. They will trig at a preset value, in response to an abnormal temperature increase when the flow decrease or stop, and when the temperature control device has failed. They are not normally included in the heaters of this catalogue, but can be installed on request</p>
	<p><u>Thermal cut outs (TCO):</u> They are intended to cut off the heating elements power supply when dry run occurs. They are usually positioned in a pocket near the tubular heater which emerges first of the liquid. They can also be incorporated inside the sheathed tubular heaters cold zone. Their response time must be short enough that the heaters power is turned off before the risk of fire. They cannot be reset and must be replaced when they have triggered. This thermal cut out is mandatory in some domestic product safety standards, such as EN60335-2-xx.</p>

Note on manual reset thermostats and fusible thermal cut out

These devices are prescribed by safety standards, usually in the EN60335-2-xx series, which the integrator must refer according to its application. Eg EN 60335-2-21 (related to storage water heaters) specify, in § 24.101: Thermal cut-outs shall be non-self-resetting. They shall have a trip-free switching mechanism or be located so that they can only be reset after removal of a non-detachable cover.

The same standard also specify in §24.102: The operating temperature of the thermal cut-out of a closed water heater shall ensure that the water temperature cannot exceed 99°C or that the thermal cut-out operates before its temperature exceeds 110°C.

Because of permanent improvement of our products, drawings, descriptions, features used on these data sheets are for guidance only and can be modified without prior advice

I - 2 Temperature sensors

Temperature sensors locations

Liquid heaters can be equipped with temperature sensors. They are not normally included in the heaters, but may be installed on demand.

Depending on the type of temperature sensor, and its use, the diameter and the position of the thermowell will be different. The sensor can be used:

- To sense the cold inlet temperature, then it is close to the inlet fitting
- To sense the hot outlet temperature, then it is close to the outlet fitting.

Some electronic controls may need measure both temperatures to calculate the instantaneous power by simultaneously measuring the liquid flow.

We have developed "add-on" nipples with sensor thermowells for mounting on existing heaters.

This solution is however more costly than the incorporation of thermowells in the body of the heater during its production assembly.

Preferred positions for temperature sensors thermowells

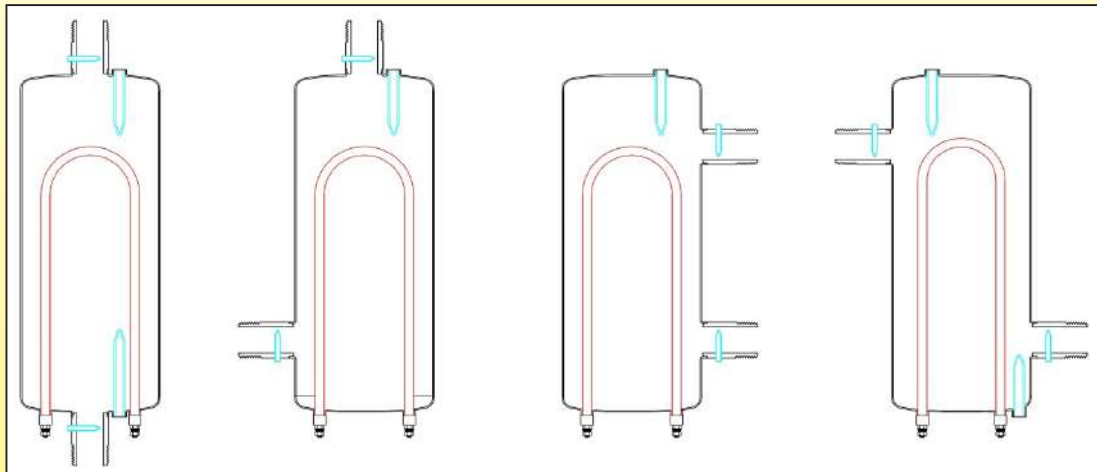

In red sheathed tubular heaters. In blue: temperaturesensors probes thermowells

Comparison of different types of temperature sensors in the normal operating temperature range of liquid heaters (between 0 and 120°C).

Features	Thermocouple (J, K, E)	RTD (Pt100, Pt1000)	Thermistor (NTC)
Interchangeability	Good	Excellent	Poor to fair
Usual probes diameters	2 to 6mm	4 to 6mm	4 to 6mm
Long-term Stability	Fair	Good	Poor
Accuracy	Poor in the range 20-100°C	High to excellent	Medium
Repeatability	Poor in the range 20-100°C	Excellent	Fair to good
Simplicity of output signal conversion to electronic	Complicated conversion	Medium	Easy
Response time	Medium to fast (upon diameter)	Medium	Medium to fast (upon diameter)
Linearity	Fair	Excellent	Poor
Self Heating	No	Very low to low	High
Lead effect on measurement	Special compensated wires are needed	Pt100: 3 wires connection is recommended. Pt1000: 2 wires are enough	Low (connection with 2 wires only)
Cost	Low	Low in class B Medium in class A	Low to very low upon requested accuracy and interchangeability



I - 3 Flow switches

	<p>Magnetic miniature flow switch</p>
	<p>Magnetic flow switch with built-in power relay</p>
	<p>Magnetic flow switch mounting kit for liquid heater</p>
	<p>Magnetic flow switch with built-in power relay mounting kit, for liquid heater</p>

Flow switches: These devices are preset to open a contact when the flow in the circuit drops below a critical value, for example as a result of locked or of failure of the external circulation pump.

Opening of this contact switches off the heating elements. These devices come in two forms: with a paddle controlling a micro-switch (system requiring a flexible gasket between the paddle and the switch), or with a paddle controlling a reed switch by the action of a magnet (Through wall detection, without need of a gasket)

These devices are usually mounted on a 3/4" fitting, with gasket seat.

Although manufacturing the two types of flow switches, for applications in heaters, we prefer to use magnetic flow switches, because they do not have through-wall mechanism, avoiding in this way the most common source of leaks in medium temperature applications and relatively high pressure.

In general, the models using a reed switch and magnet have limited switching rating of less than one amp and less than 20W, and need a power relay to operate the power circuit.

In some models, the power relay is incorporated in the sensor head and allows switching up to 16A 250V (SPDT)

Flow switches are not part of the normal equipment of heaters of this catalog, but can be added by use of tees with flow switches that can be screwed upstream of the heater on the inlet fitting. (see accessories at end of this catalogue)

Because of permanent improvement of our products, drawings, descriptions, features used on these data sheets are for guidance only and can be modified without prior advice



J - Thermal insulation

J - 1 Thermal insulation Foams

As all the components of a heating circuit, heaters dissipate part of their energy in heat exchange with the environment. The thermal insulation is intended to limit the losses that affect the circuit performance.

Most of applications of heaters of this catalogue, especially when mounted in air conditioning circuits, bring additional constraints to ensure their safe operation and longevity.

These are in particular:

- Flexibility allowing them to wrap around the tanks.
- A long-term low shrinkage rate at temperatures up to 80°C to prevent the insulation is torn by thermal shrinkage.
- Temperature resistance to avoid their auto-ignition during overheat when dry running on devices with thermal fuse (Test show the continuous temperature resistance must be greater than 105°C).
- They must resist to condensation (liquid water), which occurs when installed in a reversible heat pump refrigerant circuit which can be cold during hot season. (This request closed cells foams with less than 7% water porosity)
- An active chlorine content below 10 ppm to prevent corrosion under insulation of stainless steel tanks.

There are two types of flexible closed cell foam insulation used in the heater insulation meets these specifications. NBR-PVC foam and EPDM foam

Both foams are flexible, closed cell type and have a good temperature resistance.

There are many other types of closed cell foams, but some are not flexible (phenolic, PIR, PUR) or do not have a sufficient temperature resistance (neoprene, polystyrene, polyethylene). Some have a superior thermal performance, but at a cost which is not compatible with the applications of these products (Silicones foams, from -70 to + 200°C, Viton foam, -25 to + 200°C)

J - 2 Comparison of main technical specs of both foams

	NBR-PVC	High temperature EPDM foam
Thermal conductivity at 50°C upon EN 12667 or EN ISO 8497 (W/m.k)	≤0.043	0.038 to 0.042
Specific gravity (Kg/m³)	55-95 (average 75)	60-120 (average 100)
Service temp range (°C)	-40+105°C (-40°F + 220°F)	High temperature blends: -50+125°C (-58+260°F) Standard temperature blends: -50+90°C (-58+194°F)
Low Temperature flexibility limits	Flexible down to -30°C (-20°F)	Flexible down to -55°C (-70°F).
Shrinkage at elevated temperatures	≤6%, 7 days at 105°C (220°F)	≤6%, 7 days at 105°C (220°F)
Flame retardant class of not-foamed raw material (UL94)	UL94-HF1	UL94-HBF
“Euro Class” Fire Resistance upon Building fire classification EN13501-1 (EN13501-1 (Class E= Combustible	Class E= Combustible
Tensile strenght (Kpa)	≥345	≥400
Water Absorption Rate (%)	≤7%	≤5%
Water resistance	Resistant to moisture and excellent water resistance. Not recommended on heaters where water will drop, because continuous exposure to water over a long period of time will result in water intrusion into the closed cell structure and the eventual collapse of the cells, resulting in degradation of the thermal conductivity property of the product.	Resistant to moisture and excellent water resistance. Not recommended on heaters where water will drop, because continuous exposure to water over a long period of time will result in water intrusion into the closed cell structure and the eventual collapse of the cells, resulting in degradation of the thermal conductivity property of the product.
UV resistance	UV-resistant	More UV-resistant than NBR.
Corrosion initiation	Chloride content <10ppm When used on austenitic stainless steel at permanent temperature above 80°C (180°F), in wet conditions, it is recommended that the stainless steel be protected with a corrosion resistance coating.	Chloride content <10ppm When used on austenitic stainless steel at permanent temperature above 80°C (180°F), in wet conditions, it is recommended that the stainless steel be protected with a corrosion resistance coating.
Environmental compliance	CFC-free with zero ozone-depleting. Rohs compliant.	CFC-free with zero ozone-depleting. Rohs compliant.

Because of permanent improvement of our products, drawings, descriptions, features used on these data sheets are for guidance only and can be modified without prior advice



J - 3 Surface protection of thermal insulation foams

This protection, optional on devices, is adhesive and glued on the smooth surface of the insulating foam. It consists of a 0.1mm glass fiber fabric thickness coated with a 7 micron aluminum film.

It provides the following advantages, by order of importance in the application:

- Good temperature resistance slowing the spread of flames (fire barrier)
- Air income barrier, limiting oxygen intake during ignition, thus limiting inflammation speed.
- Mechanical protection against tearing due to foams thermal shrinkage
- Protection against ingress of liquid water (drops only)
- Mechanical protection against tearing during installation and handling
- Protection against penetration of water vapor
- Improved thermal insulation

Temperature resistance of fiberglass: 550°C

Temperature resistant aluminized film 120°C (permanent), 140°C (one hour)

Adhesive layer max temperature: 150°C (permanent)

See below comparison of the foam ignition time between protected and unprotected foam (Identical testing conditions).

J - 4 Testing reports of insulation foams critical features in heaters applications

To effectively characterize the behavior of insulating foams in applications heaters, we conducted trials involving flammability according to the thickness, water absorption, shrinkage after temperature rise, the insulating performance.

The increase in mass after immersion provides an overview of the percentage of closed cells which are open.

Changes in size outlines the risk of tearing the insulation and its loss of efficiency, in normal operation, and after an abnormal overheating.

Weigh increase as a function of the thickness, after 8 days immersion in water, new condition.

Thickness	Material	Change in weigh after immersion (ambient temperature)	Change in weigh after immersion (immersed after 3 hours at 65°C)	Change in weigh after immersion (immersed after 3 hours at 65°C, one side protected by aluminum foil)	Change in weigh after immersion (immersed after 3 hours at 120°C)	Change in weigh after immersion (immersed after 3 hours at 120°C, one side protected by aluminum foil)
5	NBR PVC	31,2%	32,6%	31,9%	31,8%	31,1%
10	NBR PVC	33,6%	35,2%	33,8%	35,2%	33,3%
10	EPDM	16,8%	17,3%	17,3%	22,8%	17,5%
20	NBR PVC	34,5%	35,4%	33,9%	39,1%	36,1%
25	NBR PVC	37%	39,5%	38,2%	36,5%	34,8%

Shrinkage as a function of the thickness, after 8 days immersion in water, new condition.

Thickness	Material	Change in length after immersion (ambient temperature)	Change in length after immersion (immersed after 3 hours at 65°C)	Change in length after immersion (immersed after 3 hours at 65°C, one side protected by aluminum foil)	Change in length after immersion (immersed after 3 hours at 120°C)	Change in length after immersion (immersed after 3 hours at 120°C, one side protected by aluminum foil)
5	NBR PVC	0,00%	0,00%	0,00%	0,30%	0,00%
10	NBR PVC	0,00%	0,00%	0,00%	0,29%	0,29%
10	EPDM	0,00%	0,00%	0,00%	0,86%	1,14%
20	NBR PVC	0,00%	0,00%	0,00%	0,00%	0,50%
25	NBR PVC	0,00%	0,00%	0,00%	0,49%	0,49%

Smoking temperature and ignition temperature as a function of insulation thickness, with temperature rise rate of 10°C/minute.

Thickness	Material	Time spend when start testing until thermal insulation foam smoked.	Temperature of tank surface when smoke started.	Maximum temperature reached.	Set fire time.	Set fire temperature.
5	NBR PVC	22 min 32s	305°C	320°C	No fire	N/A
5	NBR PVC+ aluminum foil	22 min 12s	227°C	316°C	No fire	N/A
10	NBR PVC	21 min 03s	245°C	320°C	No fire	N/A
10	NBR PVC + aluminum foil	22 min 28s	220°C	316°C	No fire	N/A
10	EPDM	25 min 15s	240°C	318°C	No fire	N/A
10	EPDM + aluminum foil	24 min	216°C	316°C	No fire	N/A
20	NBR PVC	24 min 39s	233°C	317°C	No fire	N/A
20	NBR PVC+ aluminum foil	23 min 45s	219°C	316°C	No fire	N/A
25	NBR PVC	23 min 33 s	232°C	316°C	No fire	N/A
25	NBR PVC	23 min 25s	196°C	316°C	No fire	N/A



Temperature drop vs time of a dia. 125mm tank, from 65°C, at 20°C ambient temperature, as a function of insulation thickness (New insulation, with and without aluminized fiber glass coating). NBR-PVC and EPDM foams have the same results

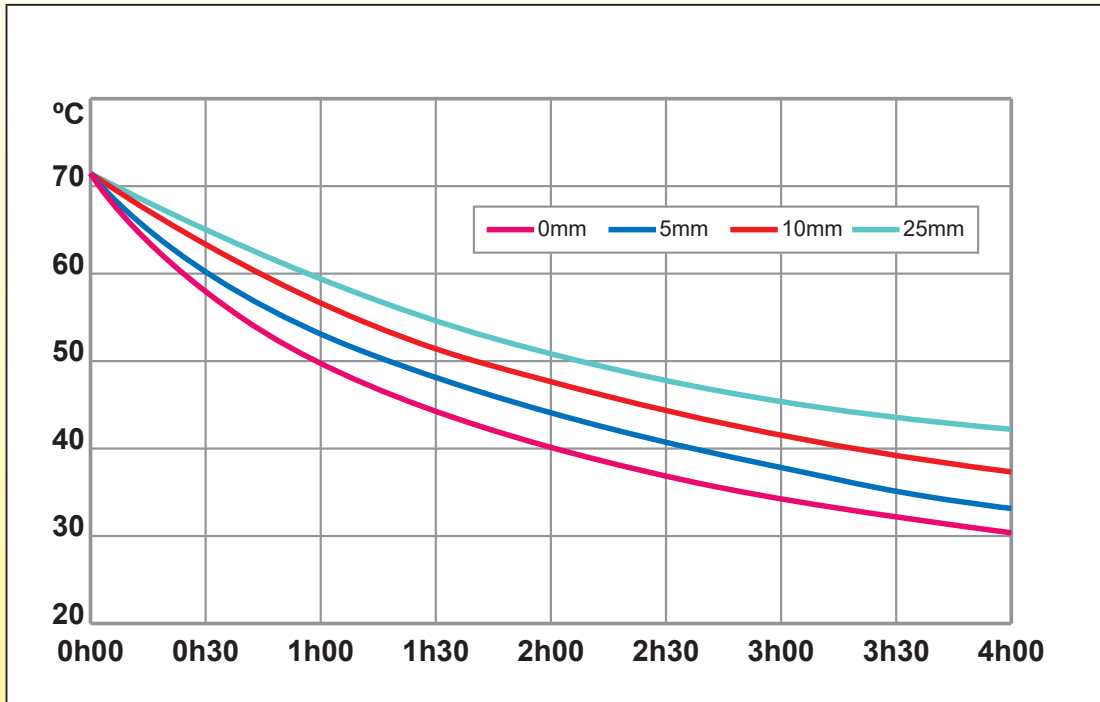

Because of permanent improvement of our products, drawings, descriptions, features used on these data sheets are for guidance only and can be modified without prior advice



K - Protection against scaling

K - 1 Anti-Scaling design rules

The water hardness

The hardness of water is defined by the total hardness, which corresponds to the presence of calcium and magnesium salts. The more the water is rich in calcium and magnesium, the more it is considered "hard". Conversely, water with low salts content is called "soft". Thus, the importance of calcium (limestone) in water is the main criterion determining the hardness of the water. The total hardness, TH is expressed in degrees, each degree determined by the formula: 1 degree (° f) = 4 mg/l of calcium or 2.43 mg/l of magnesium, or 10 mg/l of limestone

The waters are classified according to their TH:

0-6 degrees = very soft water

6 to 15 degrees = soft water

15 to 30 degrees = moderately hard water

>30 degrees = hard water

Deposits

These deposits commonly called tartar or lime, are the result of the change, under the effect of heat, of soluble bicarbonate salts dissolved in water, which decompose to form calcium carbonate and insoluble magnesium. The warmer the water is, the larger the deposits are.

There are two scenarios in the use of heaters:

- **Use in a closed loop:** the same liquid is successively heated (in the heater) and cooled (in the application). **This is the case for example of the central heating circuit, in which the tubular heaters will calcify very little despite the temperature, as there is no water renewing, the deposit will stop itself when all CaCO₃ content is deposited.** For example, a heating circuit comprising a cubic meter of water with a 15° TH will deposit a maximum of **10 grams** of calcium carbonate.

The temperature of the water is not an important parameter in these applications.

- Open loop application

Part of the minerals in the water agglomerate when passing on the heating elements. The amount that is deposited is a function of flow rate, water hardness and temperature. The hardness is a local water parameter, as well as the relative percentage of calcium and magnesium, and therefore it not possible to provide the weight of deposit nor, consequently, the possible duration of use of a heater.

The formation of scale on the heating elements reduces the heat transfer. When the thickening of the deposits increases, the heat exchange of the tubular heater with the water decreases and the water is less heated, but in return the internal temperature of the tubular heater increases because it cannot dissipate its heat. The consequence is that the internal temperature of the embedded nickel chrome heating wire in the magnesia reaches 900°C, and then chemical reactions between this wire and iron particles inside the magnesia cause its rapid destruction.

In these applications, water temperature is a critical parameter related to the product life span.

Note: use of magnesium anodes or imposed current titanium electrodes has no effect on the scaling



K - 2 Scaling deposit vs temperature

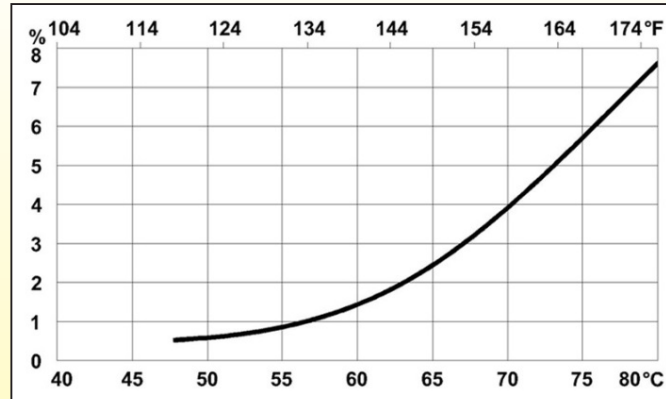

This figure shows the estimated percentage of mineral salts diluted in the circulating water that will deposit in contact with the hot walls of the tubular heater.

One can see that the temperature range 60-65°C is the critical area where deposits start to increase.



L - Protection against corrosion

L - 1 Design rules against metal corrosion

Corrosion of stainless steels.

Corrosion/oxidation is the deterioration of essential properties in a metal, due to reactions with its surroundings. In the most common usage of the word, this means a loss of an electron of metal reacting with either water or electrolytic reaction.

Despite their name, stainless steels can be susceptible to corrosion. Raw material manufacturers provide for this technical data sheets with effect of temperature conditions of use, as well as liquid and concentrations that alloys can withstand without corrosion. However, this technical information is for raw materials, which have not been subjected to mechanical or thermal processing and have not been contaminated by the transformation process.

During the manufacturing process, the “stainless” raw materials will undergo a number of transformations. **It is changes occurred during these transformations that will be the most critical, and initiate corrosion conditions, rather than the grade of the material used.**

Corrosion is a slow phenomenon rarely observed before the product is delivered, usually not detectable during the product income reception and during the assembly by the integrator, but can cause considerable damage at short to medium term by leakage after installation.

Stainless steel is a family of alloy steels containing a minimum of 10,5% chromium. The chromium, when in contact with oxygen, forms a natural barrier of chromium oxide called a “passive film”. Only microns thick, this invisible and inert film is self-repairing. To ensure stainless steel is able to “self heal” itself, it is necessary that a finished product, go through a process upon the completion of their manufacturing process. The process is called “passivation”

There are nine separate types of corrosion, that may have impact on stainless steel.

1. Crevice Corrosion

This is a common problem with stainless used in seawater applications, because of the low PH of salt water. Chlorides pit the passivated surface, where the low PH saltwater attacks the exposed metal. Lacking the oxygen to re-passivate, corrosion continues. This corrosion is most common in oxygen restricted crevices, **such as interstices between 2 parts.**

2. Pitting (Also see Galvanic Corrosion).

Stainless that had had its passivation penetrated in a small spot becomes anodic, with the passivated part remaining cathodic, causing pit type corrosion. **It can be initiated by steel or iron particles embedded in the surface during the manufacturing process.**

3. Intergranular corrosion.

At high temperature, such as encountered during **TIG welding**, the carbon forms chromium carbide, thus starving adjacent areas of the chrome it needs for its own corrosion protection.

4. Chloride stress corrosion.

Chlorides are probably the single biggest enemy of stainless steel. In most environments, the PPM are so low that the effects on stainless are minimal. In extreme environments, such as swimming pools, the effects can be extreme and potentially dangerous.

5. Galvanic Corrosion

Placing 2 dissimilar metals in a electrolyte produces an electrical current. The current flows from the anodic metal and towards the cathodic metal, and slowly removes material from the anodic metal. Seawater makes a good electrolyte, and thus, galvanic corrosion is a common problem in this environment.

6. Corrosion under insulation.

Although it is not in direct contact with the liquid flowing into the heater, the outer wall thereof is usually covered with a thermal insulator. This thermal insulation can be the cause of corrosion, by the combination of penetration of condensation water, combined with chlorine releases from the insulation. This type of corrosion is possible on the heater in normal use, in particular in air conditioning applications involving periods of refrigeration

7. Selective Leaching

Fluids will remove metal during a de-ionization or de-mineralization process. This type of corrosion never happens in standard applications of heaters of this catalogue.

8. Erosion Corrosion

This corrosion happens when the velocity of an abrasive fluid removes the passivation from a stainless. Stainless steels can operate at high flow rates, up to around 40m/s without breakdown of the surface film. Flow rates of greater than 1m/s are preferred in raw waters and greater than 0.6m/s in cleaner waters to avoid deposit build up.

This type of corrosion never happens in standard applications of heaters of this catalogue.

9. General corrosion

This type of corrosion occurs when there is an overall breakdown of the passive film. The entire surface of the metal will show a uniform sponge like appearance. This corrosion is the result of contact with highly concentrated halogens (like Fluorine, chlorine, bromine). They penetrate the passive film of stainless and allow corrosion to occur. This type of corrosion never happens in standard applications of heaters of this catalogue.

Our manufacturing process has been completely analyzed and developed to be sure that any step in the production and assembly does not modify the characteristics the raw material corrosion resistance

Moreover, after all the assembly immediately before electrical wiring, all heaters are passivated, rinsed with deionized water and dried to remove any trace of invisible contamination that might have existed.



L - 2 Intergranular corrosion

Intergranular corrosion, is a form of corrosion where the boundaries of crystallites of the material are more susceptible to corrosion than their insides.

Stainless steel intergranular corrosion is the result of the precipitation of the Chrome carbide ($Cr_{23}C_6$, Cr_7C_3) that occurs, after a certain heat treatment (600~700C), like it happens during TIG welding or high temperature brazing. These carbides whose chromium content is very high (95%), locally deplete the matrix of chromium. Its content may go down to under the 10.5% level, which is the minimum to develop the passive layer of stainless steel. Thus, in areas surrounding the carbide, stainless steel loses the ability to be resistant to corrosion. These areas, usually located some mm each side of the TIG welding seam (But that can cover the entire heater on tanks brazed at high temperature in vacuum ovens), will become more sensible to corrosion are described as "sensitized".

However, the precipitation of chromium carbides occurs in austenitic alloys having a percentage of carbon greater than 0.03%. Intergranular corrosion, however, can only develop later in these sensitized areas when the environment with chlorine, chlorides and the like.

304L (X2CrNi18-9 or 1.4307) and 316L (X2CrNiMo17-12-2 or 1.4404) alloys have been developed to limit this corrosion. (The L at the end means "Low Carbon"). Some other alloys have a better resistance, improved by adding a few percentage of Titanium, like 316Ti (X6CrNiMoTi17-12-2 or 1.4571).



L - 3 Contamination by iron oxides during the process

During the manufacturing process, particles of iron or steel from tool, dies or equipment may become embedded in the stainless steel. If not avoided during production or not removed, these particles may corrode, produce rust spots and/or contaminate the heater, and initiate pitting corrosion. Passivation will remove free iron from the heater.

L - 4 Corrosion by Chlorine and Chlorides

This corrosion occurs especially when the liquid contains chlorine and chlorides. Named chloride stress corrosion, it occurs at places where the metal has been subjected to heat or mechanical stress. The susceptibility to this corrosion is usually assessed on the basis of chloride content, pH and temperature.

Heaters in this catalogue have numerous welded seams for fittings and heating elements. They are mostly used to heat water at temperature between 50 and 80°C, and this water may have unknown additives like glycol, but also sludge with, steel, copper, plastic, zinc particles. Water used is generally tap water.

The following chemical must be considered in the tap water, for their corrosive action: **Free chlorine and chloride**

Free chlorine is the most corrosive ingredient.

Free chlorine is the amount of chlorine present in water as dissolved gas (Cl₂), hypochlorous acid (HOCl), and/or hypochlorite ion (OCl⁻) that is not combined with ammonia or other compounds in water.

When sodium hypochlorite (NaOCl, also named bleach) is added to water (well water, drinking water, swimming pool water, etc.) to kill bacteria, it will generate:

- Chlorine gas (Cl₂), a very potent oxidizer (reason it kills bacteria) and therefore high levels of Chlorine may accelerate chloride corrosion of stainless steels. But chlorine quickly bubbles out of the solution.
- Hypochlorous acid (HOCl), in various proportions, depending on the pH of the solution
- Hypochlorite ions (OCl⁻) in various proportions, depending also on the pH of the solution. It is aggressive to stainless steels, acting in a similar way to wet chlorine gas.

Tap water has usually a free chlorine level from 0.2 to 1 mg/litre. (2 to 10 ppm).

Chloride and specially ions Cl⁻, found in salts of sodium (NaCl), potassium (KCl), and calcium (CaCl₂). Pitting and crevice corrosion requires the presence of chlorides and, for a given chloride level, the more highly alloyed stainless steels are more resistant. Crevice corrosion tends to occur at lower chloride levels and temperatures than pitting. Such attack is usually localized creviced areas or contaminated by iron or iron oxides.

No health-based guideline value is proposed for chloride in drinking-water.

Tap water has usually a chloride level lower than 50 mg/liter (50 ppm), but can reaches 250mg/liter in some areas (At this level, tap water is "salty").

L - 5 Recommended stainless steel grades vs free chlorine and chloride percentage

Free Chlorine level	Chloride level (ppm), Ambient temperature, PH>6	Chloride level (ppm), at severe conditions, e.g. very tight crevices, low pH, high temperatures (80-100°C), low flow rates or risk of local concentration of higher chloride levels by deposits or dead zones	Recommended stainless steel grade (Low carbon for welded parts)
<2ppm			304L, 316L
		<50 ppm	304L, 316L
<5ppm		<250 ppm	316L
	<100ppm		304L
	<200ppm		304L, 316L
	200-1000ppm		316L

Note: The resistance of Alloys 321 to pitting and crevice corrosion in the presence of chloride ion is similar to that of 304 or 304L stainless steels. Type 316L stainless steel is a standard material used in ozone generation and for the handling of the ozonated water streams.

Because of permanent improvement of our products, drawings, descriptions, features used on these data sheets are for guidance only and can be modified without prior advice



L - 6 Design rules against galvanic corrosion, also called Bimetallic Corrosion

In line heaters may be subject to a special phenomenon which reduces their lifespan, up to the perforation of the envelope. This is galvanic corrosion.

Galvanic (Bi-Metallic) corrosion is an electrochemical phenomenon that occurs when dissimilar metals are in contact in the presence of an electrolyte (e.g. water, sea water). This will cause additional corrosion that can occur with other phenomena and uncoupled metals, and its progression is usually much faster.

A difference of potential appears between the two metals depending on both the metal and the solution. Two metals or two different alloys in contact with the same medium generally take two different potentials. If both metals are electrically connected, their difference of potential generates electrochemical reactions and an electric current flow.

The most negative metal (least noble) is positively polarized and the more positive metal is negatively biased. In the vast majority of cases, this configuration is an increase of the corrosion rate of the corrodible metal most (most negative), and a decrease in the rate of corrosion of the least corrodible metal (most positive).

In in line heaters, because the risk of water drops and condensation, it is mandatory to avoid this electrical potential as it brings very fast corrosion.

The following metals must be strongly avoided to be in contact with stainless steel, Incolloy or Titanium in wet conditions: Magnesium, Aluminum, Cadmium and Zinc (including zinc coated metals).

Joint conditions necessary for the appearance of a galvanic corrosion couple.

Galvanic corrosion is a function of several different factors that need to be carefully evaluated when assessing the likelihood to have galvanic corrosion.

The simultaneous requirements for bi-metallic corrosion are as follows:

- An electrolyte bridging the two metals
- Electrical contact between the two metals.
- A difference in potential between the metals to enable a significant galvanic current
- A sustained cathodic reaction on the more noble of the two metals.

NB: If the metals are dry, bimetallic (galvanic) corrosion cannot occur.

Electrolyte

The conductivity of electrolyte will also affect the degree of attack.

When the conductivity of the electrolyte is low, the corrosion is localized to the contact zones between the two metals.

When the conductivity of the electrolyte increases, the corroded surface increases.

Electrical contact between metals

If the electrical contact is prevented between the two metals by interposing an insulator (aluminum oxide, phosphating, paint, oil, etc ...), the current does not run and there is no corrosion

Electrical potential difference between metals

The higher the value, the greater the electromotive force of the phenomenon. A difference of hundreds of millivolts is likely to result in galvanic corrosion, but a 200-300mV difference is unlikely to be a problem.

The galvanic corrosion potentials of various metals and alloys are listed in a table which gives the metal electrical potential values and are usually measured with respect to the Standard Calomel Electrode (S.C.E "Anodic" metals such as magnesium, zinc and aluminum are more easily corroded metals than "cathodic" ones (titanium, silver, gold).

Corrosion is proportional to the potential difference between two metals.

The values to be considered are the potentials of the metals and alloys which form the torque with respect to the medium in question. These potentials are experimental values and must be distinguished from the standard potentials of thermodynamic tables. Experimental potentials are strongly influenced by parameters such as temperature, agitation and ventilation. In addition, some metals can take two different potentials when in the same environmental conditions according to whether they are active or passive (case of stainless steels in contact with sea water, for example).

These considerations show that it can be difficult to predict trends without the need for experimentation, as many parameters are likely to reverse the polarity of some galvanic couples.

Area ratio of the two metals: the worst case is when a large cathode surface (the most positive material) is electrically connected to a small anode surface (metal most negative). The corrosion rate of the most negative metal can be multiplied by 100 or by 1000.

For instance, the assembly of a disc thermostat aluminum cup (dia 16mm) on a stainless steel tank will cause a quick corrosion of the cup if the necessary joint conditions are fulfilled.

Resistance to corrosion of noble metals

- Regardless of its potential, the corrosion resistance of the most noble metal significantly influences the behavior of bimetallic couples. If the most noble metal corrodes, its corrosion products may, by motion, accelerate the corrosion of the most corroding metal. If the noble metal couple is not corroding (Gold, Platinum), it will not present a risk of galvanic corrosion regardless of the metal that will be associated.



L - 7 Some special cases of bimetallic electrochemical couples including stainless steel

Corrosion risks with galvanized steel and stainless steel in contact

Galvanized steel in contact with stainless steel is not normally considered to be a serious corrosion risk, except in marine environments.

However, in the heaters of this catalog, all galvanized steel and steel parts have been removed, and screws, washers, tubular heaters connectors are in stainless steel

Galvanic corrosion between stainless steel and aluminum

The corrosion potentials of the stainless steels are “cathodics” and located in the “noble” area. The corrosion potentials of aluminum are “Anodic” and located in the “non-noble” area, with a large potential difference. This means that there will be no galvanic corrosion on stainless steel when placed in contact with aluminum while aluminum will corrode.

Although aluminum is anodic to stainless steel, large relative surface areas of aluminum to stainless steel can be acceptable, depending on local conditions.

Stainless steel fasteners in aluminum plates or sheets are normally considered safe, whereas aluminum rivets or bolts holding stainless steel parts together is an unwise combination, as there is a practical risk of corrosion.

Even with no insulation between the metals, there should be little risk of corrosion, in continental weather conditions.

In contrast, in a marine environment, severe localized pitting corrosion to the aluminum treads has been observed where un-insulated stainless steel bolts were used to secure the treads in place.

On the same ladder however, bolts with sound insulating washers did not show any pitting on the surrounding aluminum.

Mechanical methods of reducing galvanic corrosion between aluminum and stainless steel

- Isolating the two materials by means of an electrical insulating material, like plastic, wherever practical
- Avoid relatively small areas of the less noble metal (Aluminum) and large areas of the more noble metal (Stainless steel).
- The same metal or more noble (Cathodic, higher number in the table) metals should be used for small fasteners and bolts.
- Avoid crevices in stainless steel: In the presence of crevices stainless steels may feature less noble potentials due to oxygen depletion within the crevice. Therefore, coupling a relatively large aluminum area with a small creviced area of a stainless steel part may result in rapid attack of the material within the crevice leading to stainless steel corrosion.
- Exclude electrolyte from around the bimetallic junction e.g by painting. Paint both metals where possible: if impractical paint the most noble metal
- Seal: insure that faying surfaces are water-tight.
- Apply corrosion-inhibiting pastes or compounds under screw heads or bolts inserted into dissimilar metal surfaces whether or not the fasteners have been previously plated or otherwise treated.
- In some instances, it may be feasible to apply an organic coating to the faying surfaces prior to assembly. This would be applicable to joints which are not required to be electrically conductive.
- Where practicable or where it will not interfere with the proposed use of the assembly, the external joint should be coated externally with an effective paint system.
- Avoid threaded joints for materials far apart in the galvanic series



L - 8 Electrochemical couples of various metals

Electrochemical couples of various metals, in a 2% saline solution.

There is no appearance of significant corrosion when the galvanic couple value is less than 300mV

	Pt (Platinum/ Platine)	Au (Gold/ Or)	Ti (Titanium/ Titane)	AlSi 31CL (Passive/passif)	Ag (Silver/ Argent)	Ni (Nickel/ Nickel)	NiCu 30 (Monel 400)	NiCr15Fe8 (Inconel 600)	Cu55 Zn23 Ni22 (Arcap)	Cu (Copper/ Cuivre)	Al10 Sn66 Pb34	CuZn44 (Brass/ Laiton)	Cu88 Sn12 (Bronze)	Sn (Tin/ Etain)	Pb (Lead/ Plomb)	Al Cu Mg1 (Duralumin)	Al 99. 5 (Aluminium)	Hard steel/ Acier dur	AlMg5 (Duralinox)	ADC12 (Aluminium alloy)	Cd (Cadmium/ Cadmium)	Fe (Steel / Fer)	Cr (Chromium/ Chrome)	Al Mg Si0. 7 (Almasilium)	Sn75 Zn25	Zn (Zinc/ Zinc)	Al PVD (Physical vapor deposition)	Mg (Magnesium)	
Pt (Platinum/ Platine)	0	130	250	250	350	430	430	430	450	570	600	650	770	800	840	940	1000	1065	1090	1095	1100	1100	1100	1105	1200	1350	1400	1400	1900
Au (Gold/ Or)	130	0	110	110	220	300	300	300	320	410	470	520	610	670	710	810	870	935	960	965	970	970	970	975	1070	1230	1270	1270	1820
Ti (Titanium/ Titane)	250	110	0	0	110	180	180	180	200	320	350	400	520	550	590	690	750	815	840	845	850	850	855	950	1100	1150	1150	1700	
AlSi 31CL (passive/passif)	250	110	0	0	110	180	180	180	200	320	350	400	520	550	590	690	750	815	840	845	850	850	855	950	1100	1150	1150	1700	
Ag (Silver/ Argent)	350	220	100	100	0	80	80	80	100	220	250	300	420	450	490	590	650	715	740	745	750	750	755	850	1010	1050	1050	1600	
Ni (Nickel/ Nickel)	430	300	180	180	80	0	0	0	20	110	170	220	340	370	410	510	570	635	660	665	670	670	675	770	930	970	970	1520	
Ni Cu 30 (Monel 400)	430	300	180	180	80	0	0	0	20	110	170	220	340	370	410	510	570	635	660	665	670	670	675	770	930	970	970	1520	
NiCr15 Fe8 (Inconel 600)	430	300	180	180	80	0	0	0	20	110	170	220	340	370	410	510	570	635	660	665	670	670	675	770	930	970	970	1520	
Cu55 Zn23 Ni22 (Arcap)	450	320	200	200	100	20	20	20	0	120	150	200	320	350	380	490	550	615	640	645	650	650	655	750	910	950	950	1500	
Cu (Copper/ Cuivre)	570	440	320	320	220	140	140	140	120	0	30	80	200	230	270	370	430	495	520	525	530	530	535	630	780	830	830	1380	
Al10 Sn66 Pb34	600	470	350	350	250	170	170	170	150	30	0	50	170	200	210	310	400	465	490	495	500	500	505	600	760	800	800	1350	
Cu Zn34 (Brass/ Laiton)	650	520	400	400	300	220	220	220	200	80	50	0	120	150	190	290	350	415	410	445	450	450	455	550	710	750	750	1300	
Cu88 Sn12 (Bronze)	770	640	520	520	420	340	340	340	320	200	170	120	0	30	70	170	230	295	320	325	330	330	330	335	430	430	590	630	1180
Sn (Tin/ Etain)	800	670	550	550	450	370	370	370	350	230	200	150	30	0	40	140	200	265	290	295	300	300	300	305	400	400	560	600	1150
Pb (Lead/ Plomb)	840	710	590	590	490	410	410	410	380	270	240	190	70	40	0	100	160	225	250	255	260	260	260	265	360	360	520	660	1110
Al Cu Mg1 (Duralumin)	940	810	690	690	590	510	510	510	490	370	340	290	170	140	100	0	60	125	150	155	160	160	160	165	260	260	420	560	1010
Mild steel / Acier doux	1000	870	750	750	650	570	570	570	550	430	400	350	230	200	150	60	0	65	90	95	100	100	100	105	200	200	360	400	950
Al Si 10Mg (Alpax H)	1065	935	815	815	715	635	635	635	615	495	465	415	295	265	225	125	65	0	25	30	35	35	40	135	135	295	355	355	885
Al 99. 5 (Aluminium)	1090	960	840	840	740	660	660	660	640	520	490	440	320	290	250	150	90	25	0	5	10	10	15	110	110	270	310	310	860
Hard steel / Acier dur	1095	965	845	845	745	665	665	665	645	525	495	445	325	295	255	155	95	30	5	0	5	5	5	105	105	265	305	305	855
Al Mg5 (Duralinox)	1100	970	850	850	750	670	670	670	650	530	500	450	330	300	260	160	100	35	10	5	0	0	5	100	100	260	300	300	850
ADC12 (Aluminium alloy)	1100	970	850	850	750	670	670	670	650	530	500	450	330	300	260	160	100	35	10	5	0	0	5	100	100	260	300	300	850
Cd (Cadmium/ Cadmium)	1100	970	850	850	750	670	670	670	650	530	500	450	330	300	260	160	100	35	10	5	0	0	5	100	100	260	300	300	850
Fe (Steel / Fer)	1105	975	855	855	755	675	675	675	655	535	505	455	335	305	265	165	105	40	15	10	5	5	0	95	95	255	295	295	845
Cr (Chromium/ Chrome)	1200	1070	950	950	850	770	770	770	750	630	600	550	430	400	380	260	200	135	110	105	100	100	100	95	0	160	200	200	750
Al Mg Si0. 7 (Almasilium)	1200	1070	950	950	850	770	770	770	750	630	600	550	430	400	380	260	200	135	110	105	100	100	100	95	0	160	200	200	750
Sn75 Zn25	1350	1230	1110	1110	1010	930	930	930	910	790	760	710	590	650	520	420	360	295	270	265	260	260	260	225	160	0	40	40	590
Zn (Zinc/ Zinc)	1400	1270	1150	1150	1050	970	970	970	950	830	800	750	630	600	560	460	400	335	310	305	300	300	300	295	200	40	0	0	550
Zn Al4 (Zamak3/Zamac 3)	1400	1270	1150	1150	1050	970	970	970	950	830	800	750	630	600	560	460	400	335	310	305	300	300	300	295	200	40	0	0	550
Al PVD (Physical vapor deposition)	1400	1270	1150	1150	1050	970	970	970	950	830	800	750	630	600	560	460	400	335	310	305	300	300	300	295	200	40	0	0	550
Mg (Magnesium)	1900	1820	1700	1700	1600	1600	1600	1600	1520	1500	1390	1300	1180	1150	1110	1010	950	885	860	850	850	850	845	845	590	560	560	0	0

0-300 mV	301-500 mV	501-800 mV	> 800 mV
----------	------------	------------	----------

L - 9 Corrosion under insulation

Corrosion Under Insulation is a localized corrosion occurring at the interface of a metal surface and the insulation on that surface. This can be a particularly severe form of corrosion occurring beneath insulation and at concealed interfaces. If insulation is to be applied over austenitic alloy steel where the **operating temperature is between 80°C and 200°C**, or in particularly aggressive atmospheres as it may be found in marine or coastal areas, it is recommended to apply a stress corrosion barrier before the application of the insulation so as to prevent stress corrosion.

It is recommended that the insulation be protected externally by suitable waterproof covering to prevent water ingress. The presence of moisture may lead to the buildup of soluble chlorides which will contribute to corrosion.

Most thermal insulations will not cause corrosion because of their composition, but some foam will.

This may happen with foams having chlorinated ingredients in their composition.

Insulation foams must have chloride content **below 10ppm**. If water or moisture ingress occurs through the external covering of the insulation, the insulation material may act as a collecting media and create an environment containing chlorides, moisture and oxygen, transmigrating and concentrating chlorides on hot stainless steel surfaces. If moisture is not present, the chloride salt cannot migrate, and stress corrosion cracking because of chloride contaminated insulation cannot take place

See: ASTM C692-05 Standard Test Method for Evaluating the Influence of Thermal Insulations on External Stress Corrosion Cracking Tendency of Austenitic Stainless Steel.

Because of permanent improvement of our products, drawings, descriptions, features used on these data sheets are for guidance only and can be modified without prior advice



L - 10 Corrosion aggravating factors

Design mistakes

- 1/ Design details where chlorides or iron particle can accumulate, e.g. interstices.
- 2/ Sludge deposit areas
- 3/ Air dead zones: Interface between liquid and air, because of degassing, air is trapped inside pipe output fittings, or on the top of the tank
- 4/ Surface finish: Surface roughness Ra must not exceed Ra 0.5 microns. When Ra is >1 micron, it will exhibit deep grooves where chlorine ions can accumulate and destroy the passive film, thereby initiating corrosion.
- 5/ Forming design that can create crevices in the raw material
- 6/ Contact between materials that can initiate electrolytic corrosion
- 7/ Insulation material that can initiate corrosion under insulation by migration of their chloride content.
- 8/ Sandblasting in places where stainless steel is in contact with water

Wrong manufacturing process

- 9/ Welding: not appropriate welding shield gas causing oxides
- 10/ Welding seams where chlorides can accumulate, e.g. roots of partial penetration welds.
- 11/ Edges effect: burrs on edges and edges contamination by cutting tools can initiate corrosion
- 12/ Iron contamination during manufacturing and assembly process
- 13/ Wrong or missing passivation: Passivation solution composition, concentration, temperature and time are critical parameters that will influence the corrosion resistance
- 14/ Wrong cleaning or degreasing. Parts that are not correctly degreased will not be correctly passivated.
- 15/ Dirty or wet hands in production: Fingers prints may initiate corrosion due to the sweat salt content.
- 16/ Undetected crevices caused by metal forming due to dies misalignment

Installation mistakes

- 17/ Interface between liquid and air: air is trapped inside because the wrong installation position
- 18/ Interface between liquid and air: air is trapped inside because the air bleeder is defective or not enough sensible
- 19/ Fresh scratches: they have the same effect than the surface finish.



L - 11 Summary of the rules implemented during the heaters manufacturing operations to prevent the occurrence of corrosion

Processing operations	Potential result on corrosion resistance	Techniques implemented to avoid the risks	Control method, by statistical sampling or permanent production checking.
Machining	<ul style="list-style-type: none"> - Inadequate heat treatment during manufacturing of rods and tubular blanks can cause intergranular corrosion - Machining operations with steel tools can cause the inclusion of iron particles in the parts - Prohibition of the use of stainless alloys with sulfur. (The addition of sulfur to stainless steels to improve machinability is common). Sulfides can act as initiation sites for corrosion. 	<ul style="list-style-type: none"> - Machining with carbide or ceramic tools - Reducing machining temperature by use of coolants - Storage in covered plastic containers 	<ul style="list-style-type: none"> - Raw materials - Metallographic analysis.
Raw material sheets storage	Contamination of the raw material by friction on steel or iron is causing deposits of iron particles, which cause pitting corrosion	<ul style="list-style-type: none"> - Purchase of plastic film protected sheets. - Checking of transport conditions. - Storage and handling on plastic pallets 	<ul style="list-style-type: none"> - Analysis of the contamination by iron oxides. - Raw materials composition checking
Stamping	Contamination of the raw material by friction on steel or iron is causing deposits of iron particles, which cause pitting corrosion	<ul style="list-style-type: none"> - Stamping of plastic film protected parts. - Storage and handling in plastic container 	<ul style="list-style-type: none"> - Analysis of the contamination by iron oxides.
Deep drawing and rolling	Contamination of the raw material by friction on steel or iron is causing deposits of iron particles, which cause pitting corrosion	<ul style="list-style-type: none"> - Tools and dies in austenitic stainless steel - Plastic film protected parts. - Storage and handling in plastic container or stainless steel trolleys 	<ul style="list-style-type: none"> - Analysis of the contamination by iron oxides.
Soudure TIG	<ul style="list-style-type: none"> - Contamination by friction on steel or iron parts is causing deposits of iron particles, which initiate pitting corrosion. - Welding overheating modify the metal structure and oxidize it - The speed of welding and cooling times are critical parameters to prevent crystallization at the origin of the inter-crystalline corrosion 	<ul style="list-style-type: none"> - Protection by reducing gas on both sides of the weld. - Control of welding and cooling rates. - Limitation of temperature rise. - Use of austenitic stainless steel or chromed tools and dies. 	<ul style="list-style-type: none"> - Analysis of the contamination by iron oxides. - Metallographic analysis. - Temperature and cooling time checking. - Corrosion resistance checking of welds according to ASTM.
Tubular heaters stretching	Stretching strong pressure cause the deep inclusion of metallic particles from the rollers	<ul style="list-style-type: none"> - Carbide stretching rollers 	<ul style="list-style-type: none"> - Analysis of the contamination by iron oxides.
Storage on production and packaging lines.	Airstreams cause the deposition of metal dust coming from the outside, from the building structure, or from areas of the plant where are manufactured steel parts. These dusts can initiate pitting corrosion.	<ul style="list-style-type: none"> - Protection against dust deposits. - Daily cleaning of workstations and floor 	<ul style="list-style-type: none"> - Analysis of the contamination by iron oxides - Permanent checking of dust rate in production workshops and their rate of ferric particles
Assembly and hand processing operations.	Friction on metal tables or hits with hand tools causes the inclusion of iron particles.	<ul style="list-style-type: none"> - Dedicated assembly lines, used only for stainless steel parts assembly. - Worktables and tools made in stainless steel or plastic 	<ul style="list-style-type: none"> - Analysis of the contamination by iron oxides
Water leak tests	<ul style="list-style-type: none"> - Friction on metal tables or hits with hand tools causes the inclusion of iron particles. - Uncontrolled liquids use can bring oxides or metal particles 	<ul style="list-style-type: none"> - Dedicated assembly lines, used only for stainless steel parts assembly. - Worktables and tools made in stainless steel or plastic - Use of pure water or controlled liquids 	<ul style="list-style-type: none"> - Analysis of the contamination by iron oxides
Sand blasting (This operation is made only on specific customer request)	Abrasives are usually grinded by metal wheels. Particles from the wear of the wheels can be found in the abrasive, sometimes in high percentage.	<ul style="list-style-type: none"> - Prohibition of use of grinded abrasives use. - Verification of contamination of sand by ferric oxides. - Preferential sandblasting with glass beads. 	<ul style="list-style-type: none"> - Abrasive sand screening with magnetic trap - Verification of non-abrasive powders contamination by iron oxides
Packing	<ul style="list-style-type: none"> - Friction on metal tables causes the inclusion of iron particles. - Dust contamination risk if long storage 	<ul style="list-style-type: none"> - Packing tables covered with polyethylene boards - Individual packing with plastic film 	<ul style="list-style-type: none"> - Checking of iron contamination of tables with chemical spray
Passivation	<p>Passivation loses its effectiveness in the following cases:</p> <ul style="list-style-type: none"> - The passivation solution may be contaminated - The bath temperature may be wrong - Passivation time may be too long or too short - Rinsing can be forgotten 	<ul style="list-style-type: none"> - Only 100% stainless steel products are passivated. - Soldering fillers, copper, steel, brass, tin solders are prohibited in the passivation bath. - pH, temperature and concentration are continuously monitored with automatic measurement devices with visual and audible alarm - Processing speed is automated. - Rinsing is automated 	<ul style="list-style-type: none"> - Passivation chemical checking

Because of permanent improvement of our products, drawings, descriptions, features used on these data sheets are for guidance only and can be modified without prior advice



L - 12 Protection by sacrificial magnesium anodes

In order to fight against corrosion, especially those affecting the steel and iron tanks and pipes, has been developed a technique using galvanic couples to protect against corrosion.

An anode, generally in magnesium is incorporated in the hydraulic circuit so that the electrolysis reaction, which, in presence of water, appears spontaneously between the magnesium and the steel walls of the tank, takes place between the most “noble” metal (steel) and less “noble” (magnesium).

Under the effect of this current, the anode dissolves slowly, magnesium is released and deposits on unprotected metal parts of the tank. This anode is called “sacrificial” as it gradually dissolves. This technique is widely used in storage water heater, because for reasons of economy, they are made of steel, covered with an anticorrosive enamel layer. This enamel is naturally slightly porous and more, frequent variations in temperature coupled with slightly different expansion coefficients between enamel and metal cause micro-cracks of the protective layer in which the metal corrodes and eventually causes leaks. These solutions increase the lifetime, which is however limited to that of the anode.

These electrodes are not needed in heaters inside stainless steel tanks, because the corrosion does not occur, if they are manufactured by the rules of art.

L - 13 Protection by imposed current electrode

To avoid the problem of wear of the magnesium anode, the latter may be replaced by a titanium electrode. The electrochemical reaction is then produced by a power supply which requires an electric current of a few volts to cause the deposition of certain minerals naturally present in water, especially magnesium, on the exposed walls of the vessel and thus protect it. This protection provides the benefits to last in time, but to be effective, it requires a magnesium-rich water, a proper grounding of the tank, and a permanent power supply.

Its effectiveness will be void if any of the three are missing.

To overcome the risk associated with the composition of the water, have been developed products said “hybrid electrodes” combining magnesium anode and titanium electrode, but they only prolong the life of the magnesium electrode.

These electrodes are not needed in heaters inside stainless steel tanks, because the corrosion does not occur, if they are manufactured by the rules of art.



M - Main formula

M - 1 Ohm's law

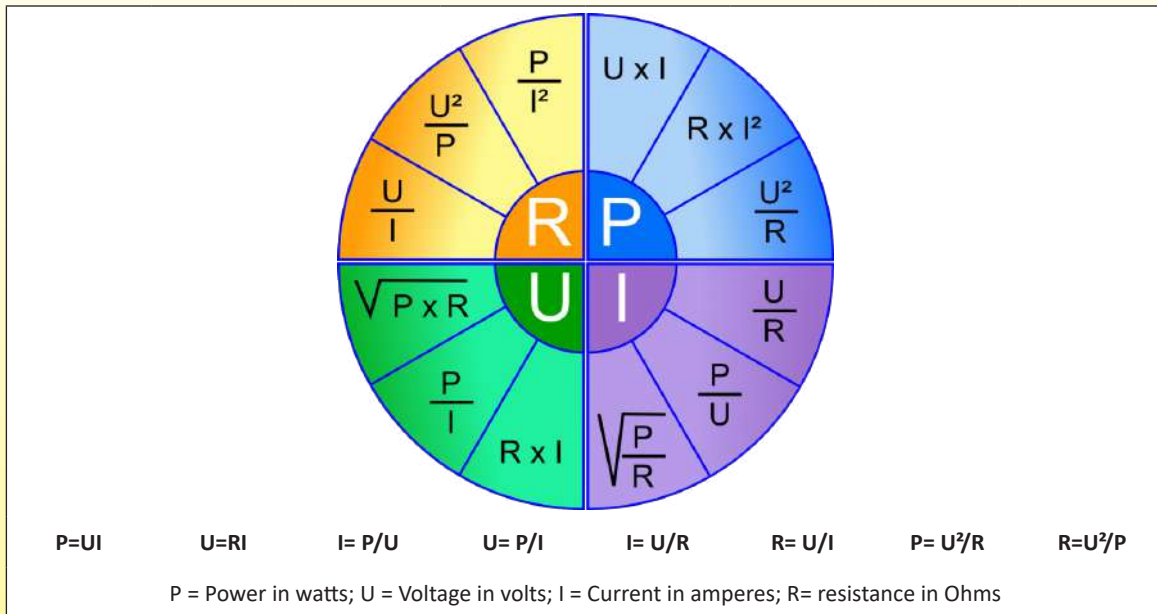

M - 2 Table of the power in watts of an electrical heater versus resistance and voltage across terminals

Ohmic resistance (ohms)	Power in 12V	Power in 24V	Power in 48V	Power in 115V	Power in 220V	Power in 230V	Power in 240V	Power in 380V	Power in 400V
1000	0,1	0,6	2,3	13	48	53	58	144	160
500	0,3	1,2	4,6	26	97	106	115	289	320
265	0,5	2,2	8,7	50	183	200	217	545	600
212	0,7	2,7	10,9	62	228	250	272	681	755
106	1,4	5,4	21,7	125	457	500	543	1362	1500
100	1,4	5,8	23	132	484	529	576	1444	1600
90	1,6	6,4	26	147	538	588	640	1604	1778
70,5	2,0	8,2	33	188	687	750	817	2048	2270
52,9	2,7	10,9	44	250	915	1000	1089	2730	3000
50	2,9	11,5	46	265	968	1058	1152	2888	3200
42,3	3,4	13,6	54	313	1144	1250	1362	3414	3783
40	3,6	14,4	58	331	1210	1323	1440	3610	4000
35,3	4,1	16,3	65	375	1371	1500	1632	4091	4533
30	4,8	19,2	77	441	1613	1763	1920	4813	5333
26,4	5,5	21,8	87	500	1833	2000	2182	5470	6000
21,15	6,8	27,2	109	625	2288	2500	2723	6827	7565
20	7,2	29	115	661	2420	2645	2880	7220	8000
17,6	8,2	33	131	750	2750	3000	3273	8205	9091
13	11,1	44	177	1000	3723	4000	4431	11108	12308
10,55	13,6	55	218	1254	4588	5000	5460	13687	15166
5	29	115	461	2645	9680	10580	11520	28880	32000
2	72	288	1152	6613	24200	26450	28800	72200	80000
1	144	576	2304	13225	48400	52900	57600	144400	160000

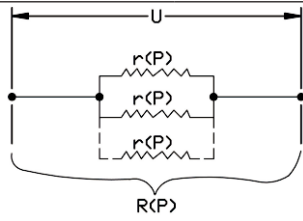
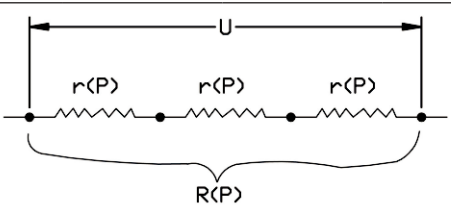

M - 3 Single phase heating elements wiring

Parallel wiring				Serial wiring			
							
Quantity of elements (n)	Total resistance (R)	Total power (P)	Heating element Watt density (w/cm ²)	Quantity of heating elements (n)	Total resistance (R)	Total power (P)	Heating element Watt density (w/cm ²)
2	$R = r/2$	$P = 2p$	Unchanged	2	$R = 2r$	$P = p/2$	Divided by 4
3	$R = r/3$	$P = 3p$	Unchanged	3	$R = 3r$	$P = p/3$	Divided by 9
n	$R = r/n$	$P = np$	Unchanged	n	$R = Xr$	$P = p/n$	Divided by n ²

M - 4 3 Phase heating elements connections

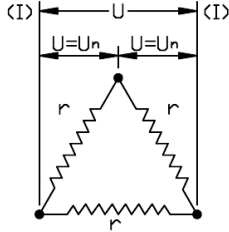
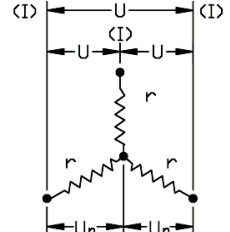
Delta connection					Star connection				
									
The voltage measured at the heating elements terminal is the same than the power supply nominal voltage: $U = U_n$					The voltage measured at the heating elements terminal is the power supply nominal voltage divided by $\sqrt{3}$: $U = 1.737$ (if $U = 400V$, $U_n = 230V$)				
Supply voltage (U)	230V, 3 phases	230V, 3 phases	400V, 3 phases	400V, 3 phases	Supply voltage (U)	230V, 3 phases	230V, 3 phases	400V, 3 phases	400V, 3 phases
Heating elements nominal voltage (Un)	230V	400V	230V	400V	Heating elements nominal voltage (Un)	230V	400V	230V	400V
Watt density (W /cm ²)	No change in watt density.	Watt density is divided by 3.	Watt density is multiplied by 6.	No change in watt density.	Watt density (W /cm ²)	Watt density is divided by 3.	Watt density is divided by 9.	No change in watt density.	Watt density is divided by 3.
Total power (P)	Total power is 3 time nominal power of one heating element ($P = 3 p$).	Total power is divided by 9. It is 1/3 of nominal power of one heating element ($P = p/3$).	Total power is 9 time nominal power of one heating element ($P = 9 p$).	Total power is 3 time nominal power of one heating element ($P = 3 p$).	Total power (P)	Total power is 1/3 of total possible power: it is the same than one heating element ($P = p$).	Total power is 1/9 of total possible power. 1/3 nominal power of one heating element ($P = p/3$).	Total power is 3 time nominal power of one heating element ($P = 3 p$).	Total power is 1/3 of total possible power. it is the same than one heating element ($P = p$).
Comments	Solution without any technical problem.	This configuration can be used as the low power step in a Star/ Delta) connection system.	Never use. Fire hazard!	This is the most common configuration.	Comments	Not recommended.	Not recommended.	This is the most standard connection, allows the same heaters to be used with 400V star connection or 230V delta connection without power change	Not recommended.

Because of permanent improvement of our products, drawings, descriptions, features used on these data sheets are for guidance only and can be modified without prior advice

M - 5 Calculation of the power needed to heat liquids

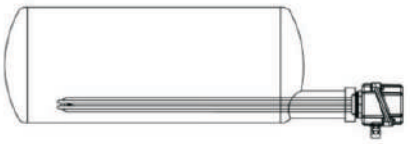
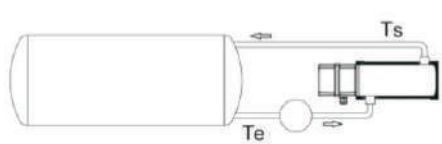
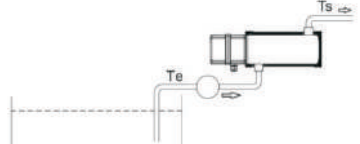
Use of immersion heaters to raise the temperature of non-circulating liquid in tanks	Using a circulation heater to raise the temperature of liquid circulating in a closed loop in tanks	Using a circulation heater to raise the temperature of a flow of liquid in a single pass
		
$P = V \times \rho \times c_p (T_f - T_i) / 3600 \times t$	$P = V \times \rho \times c_p (T_f - T_i) / 3600 \times t$	$P = Q \times \rho \times C_p (T_s - T_e) / 3600$ $T_s - T_e = P \times 3600 / Q \times \rho \times c_p$
P = Power needed in kW V = Volume of liquid in m ³ ρ = Liquid specific gravity in kg/m ³ cp = Specific heat in kJ/kg°C Tf = Required final temperature in °C Ti = Starting temperature in °C t = Required warm up time in hours	P = Power needed in kW V = Volume of liquid in m ³ ρ = Liquid specific gravity in kg/m ³ cp = Specific heat in kJ/kg°C Tf = Required final temperature in °C Ti = Starting temperature in °C t = Required warm up time in hours	P = Power needed in kW Q = Liquid flow in m ³ /hour ρ = Liquid specific gravity in kg/m ³ cp = Specific heat in kJ/kg°C Ts = Outlet temperature in °C, Te = Inlet temperature in °C

M - 6 Temperature rise of **water** in °C per hour/volume/power (Theoretical calculation, thermal losses not deducted)

Power supply (kW)	Circulating flow, temperature difference between inlet and outlet						Storage heater volume, water temperature rise					
	0.5L/min	1L/min	2L/min	3L/min	5L/min	10L/min	100L	200L	300L	500L	1000L	
	ΔT °C	ΔT °C	ΔT °C	ΔT °C	ΔT °C	ΔT °C	ΔT °C/h	ΔT °C/h	ΔT °C/h	ΔT °C/h	ΔT °C/h	
1	29	14	7,2	4,8	2,9	1,4	5,2	2,6	1,7	1,0	0,5	
1,5	43	21	11	7,2	4,3	2,1	7,7	3,9	2,6	1,5	0,8	
2	57	29	14	10	5,7	2,9	10	5,2	3,4	2,1	1,0	
2,5	72	36	18	12	7,2	3,6	13	6,4	4,3	2,6	1,3	
3	86	43	21	14	8,6	4,3	15	7,7	5,2	3,1	1,5	
3,5	100	50	25	17	10	5,0	18	9,0	6,0	3,6	1,8	
4	115	57	29	19	11	5,7	21	10	6,9	4,1	2,1	
4,5	129	64	32	21	13	6,4	23	12	7,7	4,6	2,3	
5	143	72	36	24	14	7,2	26	13	8,6	5,2	2,6	
5,5	158	79	39	26	16	7,9	28	14	9,5	5,7	2,8	
6	172	86	43	29	17	8,6	31	15	10	6,2	3,1	
6,5	186	93	47	31	19	9,3	34	17	11	6,7	3,4	
7	200	100	50	33	20	10	36	18	12	7,2	3,6	
8	229	115	57	38	23	11	41	21	14	8,2	4,1	
9	258	129	64	43	26	13	46	23	15	9,3	4,6	
10	286	143	72	48	29	14	52	26	17	10	5,2	
15	430	215	107	72	43	21	77	39	26	15	7,7	
20	573	286	143	95	57	29	103	52	34	21	10	
30	859	430	215	143	86	43	155	77	52	31	15	
40	1146	573	286	191	115	57	206	103	69	41	21	



Because of permanent improvement of our products, drawings, descriptions, features used on these data sheets are for guidance only and can be modified without prior advice

M - 7 Comparison of temperature rise in °C per hour vs power for some liquids and solids (Theoretical calculation, thermal losses not deducted)

Power (KW)	Volume of concrete					Volume of olive oil					Volume of water				
	0.1m ³	0.2m ³	0.3m ³	0.5m ³	1m ³	100L	200L	300L	500L	1000L	100L	200L	300L	500L	1000L
1	11,7	5,9	3,9	2,3	1,2	11,8	5,9	3,9	2,4	1,2	5,2	2,6	1,7	1,0	0,5
1,5	17,6	8,8	5,9	3,5	1,8	17,7	8,9	5,9	3,5	1,8	7,7	3,9	2,6	1,5	0,8
2	23	11,7	7,8	4,7	2,3	24	11,8	7,9	4,7	2,4	10	5,2	3,4	2,1	1,0
2,5	29	14,7	9,8	5,9	2,9	30	14,8	9,8	5,9	3,0	13	6,4	4,3	2,6	1,3
3	35	17,6	11,7	7,0	3,5	35	17,7	11,8	7,1	3,5	15	7,7	5,2	3,1	1,5
3,5	41	20,5	13,7	8,2	4,1	41	20,7	13,8	8,3	4,1	18	9,0	6,0	3,6	1,8
4	47	23	15,7	9,4	4,7	47	24	15,7	9,4	4,7	21	10	6,9	4,1	2,1
4,5	53	26	17,6	10,6	5,3	53	27	17,7	10,6	5,3	23	12	7,7	4,6	2,3
5	59	29	19,6	11,7	5,9	59	30	19,7	11,8	5,9	26	13	8,6	5,2	2,6
5,5	65	32	21,5	12,9	6,5	65	32	21,6	13,0	6,5	28	14	9,5	5,7	2,8
6	70	35	23	14,1	7,0	71	35	24	14,2	7,1	31	15	10	6,2	3,1
6,5	76	38	25	15,3	7,6	77	38	26	15,3	7,7	34	17	11	6,7	3,4
7	82	41	27	16,4	8,2	83	41	28	16,5	8,3	36	18	12	7,2	3,6
8	94	47	31	18,8	9,4	94	47	31	18,9	9,4	41	21	14	8,2	4,1
9	106	53	35	21,1	10,6	106	53	35	21,2	10,6	46	23	15	9,3	4,6
10	117	59	39	23	11,7	118	59	39	24	11,8	52	26	17	10	5,2
15	176	88	59	35	17,6	177	89	59	35	17,7	77	39	26	15	7,7
20	235	117	78	47	23	**	118	79	47	24	**	52	34	21	10
30	352	176	117	70	35	**	177	118	71	35	**	77	52	31	15
40	470	235	157	94	47	**	236	157	94	47	**	**	69	41	21

** Note: calculation not valid above boiling temperature

M - 8 Specific heat (cp, in kJ/kg°C) and specific gravity (ρ, in Kg/m³) of main liquids

Specific Heat: The specific heat is the amount of heat required to change a unit mass* of a substance by one degree in temperature. (*When volume is used, it must be converted in mass with the specific gravity table)

Liquids	Specific heat (cp)			Specific gravity (ρ)	
	SI	British/US	Metric	SI	British/US
	kJ/(kg°C)	Btu/(lb°F)	kcal/(kg°C)	kg/m ³	Lb/ft ³
Acetic acid	2,18	0,51	0,51	1048	65,4
Alcohol, ethyl, 95%, @ 0°C (32°F) (ethanol)	2,3	0,55	0,55	807	50,4
Ammonia, @ 40°C (104°F)	4,86	1,16	1,16	767	47,9
Dowtherm heat transfer fluid @ 50°C (120°F)	1,55	0,37	0,37	944	58,9
Ethylene glycol 25% by volume in water, @ 70°C (160°F)	3,93	0,94	0,94	1018	63,5
Ethylene glycol 30% by volume in water, @ 70°C (160°F)	3,87	0,925	0,925	1025	64,0
Ethylene glycol 40% by volume in water, @ 70°C (160°F)	3,73	0,89	0,89	1038	64,8
Ethylene glycol/water, 50% by volume in water @ 70°C (160°F)	3,56	0,85	0,85	1050	65,5
Ethylene glycol, pure, @ 70°C (160°F)	2,36	0,56	0,56	1120	69,9
Freon R-12 saturated @ 50°C (120°F)	1,02	0,244	0,244	1310	81,8
Fuel Oil min.	1,67	0,4	0,4	809	50,5
Fuel Oil max.	2,09	0,5	0,5	944	58,9
Gasoline	2,22	0,53	0,53	673	42,0
Glycerine	2,43	0,58	0,58	1261	78,7
Kerosene	2,01	0,48	0,48	809	50,5
Milk	3,93	0,94	0,94	1028	64,2
Oil, vegetable	1,67	0,4	0,4	921	57,5
Olive oil	1,97	0,47	0,47	929	58,0
Paraffin	2,13	0,51	0,51	897	56,0
Soya bean oil	1,97	0,47	0,47	920	57,4
Water, fresh @ 20°C	4,19	1	1	1000	62,4
Water, sea @ 20°C	3,93	0,94	0,94	1028	64,2



M - 9 Specific heat (cp, in kJ/kg°C) and specific gravity (ρ, in Kg/m³) of main solids.

Solids	Specific heat (cp)			Specific gravity (ρ)	
	SI	British/US	Metric	SI	British/US
	kJ/(kg°C)	Btu/(lb°F)	kcal/(kg°C)	kg/m ³	Lb/ft ³
Aluminum (@0°C)	0.87	0.21	0.21	2700	168
Copper	0.39	0.09	0.09	8920	556
Brass	0.38	0.09	0.09	7300 ~ 8800	455 ~ 549
Steel	0.46	0.11	0.11	7500 ~ 8100	468 ~ 506
Concrete	0.75 ~ 0.96	0.18 ~ 0.23	0.18 ~ 0.23	2200 ~ 2500	137 ~ 156

M - 10 Water flow for usual liquid heaters

	Domestic shower, small	Domestic shower, large	Central heating circulation pump, low speed	- Central heating circulation pump medium speed - Spa heater small circulation pump	- Central heating circulation pump medium speed - Spa heater large circulation pump	Main Spa pump, low speed	Main Spa pump, high speed	Swimming pool or swimming spa pump
L/min.	2	5	10	20	50	100	250	500
US gallons/min.	0.53	1.32	2.64	5.28	13.2	26.4	65.4	132

Because of permanent improvement of our products, drawings, descriptions, features used on these data sheets are for guidance only and can be modified without prior advice



List of references



Because of permanent improvement of our products, drawings, descriptions, features used on these data sheets are for guidance only and can be modified without prior advice

Alphabetical list



Because of permanent improvement of our products, drawings, descriptions, features used on these data sheets are for guidance only and can be modified without prior advice

Reference	Reference	Reference	Reference	Reference
9SU107A615E00000	9SU331G675G11000	9SU531E690Y11E00	4RSFMD055COB8051	5MA3SPF121F18500
9SU107A630E00000	9SU331G638G11000	9SU531E645Y11E00	4RSFMD065D0B8051	5MA3SPF129F18500
9SU107E615E00E00	9SU331A675G11000	9SU531F690Y11000	4RSFMD075D0B8051	5MA3SPF139F18500
9SU107E630E00E00	9SU331A638G11000	9SU531F645Y11000	4RSFMD085D0B8051	5MA3SPF152F18500
9SU113A615E00000	9SU331B675G11E00	9SU531G690Y11000	4RSFMD090D0B8051	5MA3SPF165F18500
9SU113A630E00000	9SU331B638G11E00	9SU531G645Y11000	49SFMD040CAB8051	5MA3SPF169F18500
9SU113E615E00E00	9SU331C675G11E00	9SUE31C6C9G11E00	49SFMD055DAB8051	5MA3SPF182F18500
9SU113E615E00E00	9SU331C638G11E00	9SUE31C665G11E00	49SFMD060DAB8051	5MA3SPF188F18500
9SU231A675G00000	9SU331E675G11E00	9SUE31D6C9G11000	49SFMD070DAB8051	5MA3SPF216F18500
9SU231A638G00000	9SU331E638G11E00	9SUE31D665G11000	49SFMD075DAB8051	5MA3SPF227F18500
9SU231B675G00E00	9SU331F675G11000	9SUE31E6C9G11E00	49SFMD095DAB8051	5MA3SPF240F18500
9SU231B638G00E00	9SU331F638G11000	9SUE31E665G11E00	8L0070105AO61001	R1X671034G35N200
9SU231C675G00E00	9SU331G675G11000	9SUE31F6C9G11000	8L0080105AA61001	R1X671234G35N200
9SU231C638G00E00	9SU331G638G11000	9SUE31F665G11000	8L0080105AO61001	R1X671034G35N200
9SU231E675G00E00	9SU431A675G11000	9SUE31G6C9G11000	8L0080105AA61001	R1X672650G35N200
9SU231E638G00E00	9SU431A638G11000	9SUE31G665G11000	8L0090115AO61001	R1X671550G35N200
9SU231F675G00000	9SU431B675G11E00	9SU631C6R0Z22E00	8L0090115AA61001	R1X671034G35N200
9SU231F638G00000	9SU431B638G11E00	9SU631C690Z22E00	8L0100120AO61001	R1X672650G35N200
9SU231G675G00000	9SU431C675G11E00	9SU631D6R0Z22000	8L0100120AA61001	R1X671550G35N200
9SU231G638G00000	9SU431C638G11E00	9SU631D690Z22000	8L0110135AO61001	RAX671034G31N00E
9SUB31A696G00000	9SU431E675G11E00	9SU631E6R0Z22E00	8L0110135AA61001	RAX671234G31N00E
9SUB31A648G00000	9SU431E638G11E00	9SU631E690Z22E00	8L0120145AO61001	RAX671034G31N00E
9SUB31B696G00E00	9SU431F675G11000	9SU631F6R0Z22000	8L0120145AO61001	RAX67265QG31N00E
9SUB31B648G00E00	9SU431F638G11000	9SU631F690Z22000	8L0130155AO61001	RAX671550G31N00E
9SUB31C696G00E00	9SU431G675G11000	9SU631G6R0Z22000	8L0130155AA61001	RAX671034G31N00E
9SUB31C648G00E00	9SU431G638G11000	9SU631G690Z22000	8L0150175AO61001	RAX672650G31N00E
9SUB31E696G00E00	9SUD31A6B4G11000	9SU731C6R0Z22E00	8L0150175AA61001	RAX671550G31N00E
9SUB31E648G00E00	9SUD31A657G11000	9SU731C690Z22E00	820060090AI61001	6R1T34208510S
9SUB31F696G00000	9SUD31B6B4G11E00	9SU731D6R0Z22000	820060090AA61001	6R1T34208510T
9SUB31F648G00000	9SUD31B657G11E00	9SU731D690Z22000	820070100AI61001	6R1T34268514S
9SUB31G696G00000	9SUD31C6B4G11E00	9SU731E6R0Z22E00	820080110AI61001	6R1T34268514T
9SUB31G648G00000	9SUD31C657G11E00	9SU731E690Z22E00	820090120AI61001	6R1P3419S
9SU331A675G11000	9SUD31E6B4G11E00	9SU731F6R0Z22000	820110140AI61001	6R1P3419T
9SU331A638G11000	9SUD31E657G11E00	9SU731F690Z22000	820130160AI61001	69SUPAM38N
9SU331B675G11E00	9SUD31F6B4G11000	9SU731G6R0Z22000	820150180AI61001	69SUPAA38B
9SU331B638G11E00	9SUD31F657G11000	9SU731G690Z22000	5MA3SPF070F18500	69SUS0338B
9SU331C675G11E00	9SUD31G6B4G11000	9SU831C690Y22E00	5MA3SPF077F18500	69SUSL7040S
9SU331C638G11E00	9SUD31G657G11000	9SU831C645Y22E00	5MA3SPF084F18500	69SUSL8570S
9SU331E675G11E00	9SU531C690Y11E00	9SU831D690Y22E00	5MA3SPF091F18500	69SUSL7040V
9SU331E638G11E00	9SU531C645Y11E00	9SU831D645Y22E00	5MA3SPF096F18500	69SUSL8570V
9SU331F675G11000	9SU531D690Y11000	9SU831F690Y22000	5MA3SPF106F18500	69SUFRG18300B100
9SU331F638G11000	9SU531D645Y11000	9SU831F690Y22000	5MA3SPF109F18500	69SUFRG18300L100
				69SUFRG18300V100



Because of permanent improvement of our products, drawings, descriptions, features used on these data sheets are for guidance only and can be modified without prior advice



Because of permanent improvement of our products, drawings, descriptions, features used on these data sheets are for guidance only and can be modified without prior advice

Standard liquids heaters



Because of permanent improvement of our products, drawings, descriptions, features used on these data sheets are for guidance only and can be modified without prior advice



Standard liquids heaters

70mm diameter, length 70mm, 1" fittings

Diameter (mm)	Tank length (mm)	Mounting	Tubular heaters Qty	Maximum power	Type
70	70	Vertical or horizontal	1	1500w (10W/cm ²) 3000w (20W/cm ²)	9SU107



Vertical (A)

Horizontal (E)

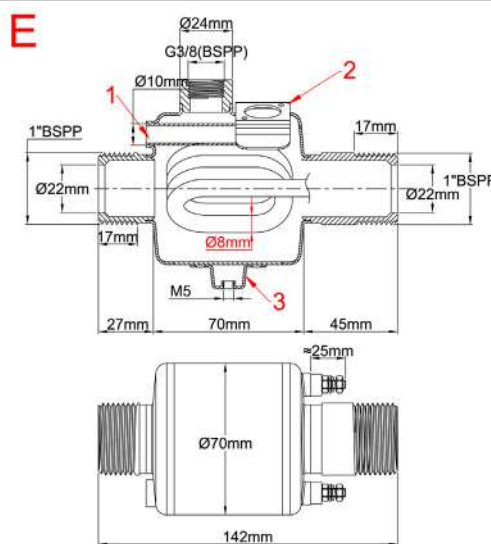
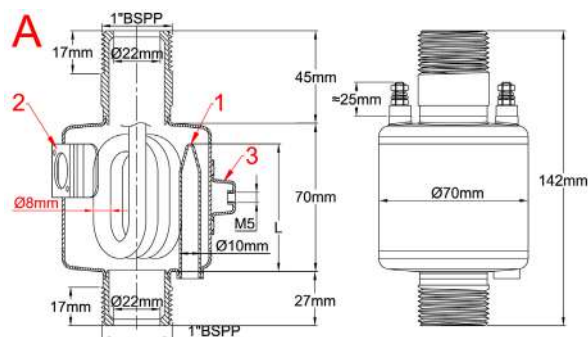

Tubular heaters dia.: 8mm

Tubular heaters material: 316L (Incolloy 800 optional)

Quantity of tubular heaters: 1.

Body material: 304L stainless steel (316L optional)

Material fittings: 304L stainless steel (316L optional)

Inlet connection: Male 1" BSPP cylindrical

Outlet diameter: Male 1" BSPP cylindrical

Centre line inlet outlet: Coaxial

Air vent thread: 3/8" BSPP (on horizontal model)

Thermowell (1): 304L stainless steel dia. 10 x 8.5mm, length 60mm for thermal cut-out (See thermal cut-out sub assembly models at end of this catalog). Copper thermowell is available on request. This thermowell can also be used for a thermostat bulb or a temperature sensor.

Disc thermostat mounting bracket (2): 1 bracket for thermostat with extended cup (see thermostat models at the end of catalog).

Wall mounting brackets (3): One M5 bracket. Can also be used for grounding.

Accessories: See end of catalog

Standard products, 304L stainless steel tanks, 316L sheathed heaters

References	Style	Surface load (W/cm ²)	Heating elements dia.	Qty of heating elements	Voltage	Power
9SU107A615E00000	A	10	8	1	230V	1.5kW
9SU107A630E00000	A	20	8	1	230V	3kW
9SU107E615E00E00	E	10	8	1	230V	1.5kW
9SU107E630E00E00	E	20	8	1	230V	3kW

Power values are the maximum possible power for a given surface load. It is possible to reduce the power by reducing the surface load.



Standard liquids heaters

70mm diameter, length 130mm, 1" fittings

Diameter (mm)	Tank length (mm)	Mounting	Tubular heaters Qty	Maximum power	Type
70	130	Vertical or horizontal	1	1500w (5W/cm ²) 3000w (10W/cm ²)	9SU113

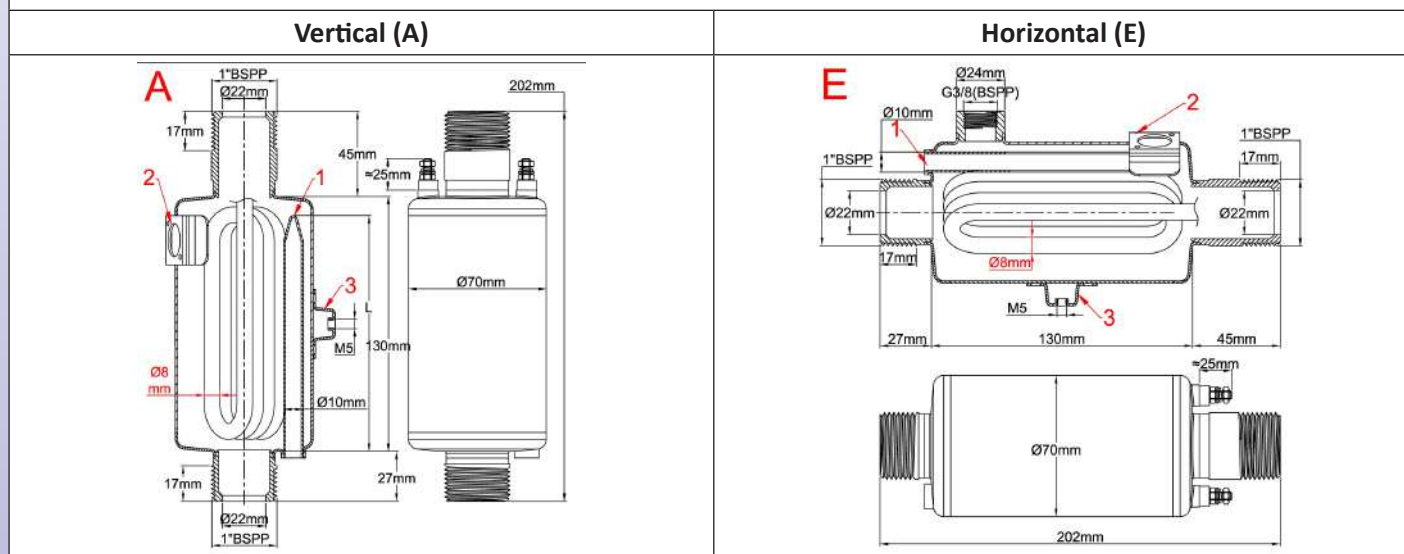

Tubular heaters dia.: 8mm

Tubular heaters material: 316L (Incolloy 800 optional)

Quantity of tubular heaters: 1.

Body material: 304L stainless steel (316L optional)

Material fittings: 304L stainless steel (316L optional)

Inlet connection: Male 1" BSPP cylindrical

Outlet diameter: Male 1" BSPP cylindrical

Centre line inlet outlet: coaxial

Air vent thread: 3/8" BSPP (on horizontal model)

Thermowell (1): 304L stainless steel dia. 10 × 8.5mm, length 120mm for thermal cut-out (See thermal cut-out sub assembly models at end of this catalog). Copper thermowell is available on request. This thermowell can also be used for a thermostat bulb or a temperature sensor.

Disc thermostat mounting bracket (2): 1 bracket for thermostat with extended cup (see thermostat models at the end of catalog).

Wall mounting brackets (3): one M5 bracket. Can also be used for grounding.

Accessories: see end of catalog

Standard products, 304L stainless steel tanks, 316L sheathed heaters

References	Style	Surface load (W/cm ²)	Heating elements dia.	Qty of heating elements	Voltage (V)	Power (kW)
9SU113A615E00000	A	5	8	1	230V	1.5
9SU113A630E00000	A	10	8	1	230V	3
9SU113E615E00E00	E	5	8	1	230V	1.5
9SU113E630E00E00	E	10	8	1	230V	3

Power values are the maximum possible power for a given surface load. It is possible to reduce the power by reducing the surface load.



Standard liquids heaters

76mm diameter, length 313mm, hairpin tubular heaters, 1" fittings

Diameter (mm)	Tank length (mm)	Mounting	Tubular heaters Qty	Maximum power	Type
76	313	Vertical or horizontal	3	3.75kW (3 × 1.25kW, 5W/cm ²) 7.5kW (3 × 2.5kW, 10W/cm ²)	9SU231



Vertical (A, B, C)

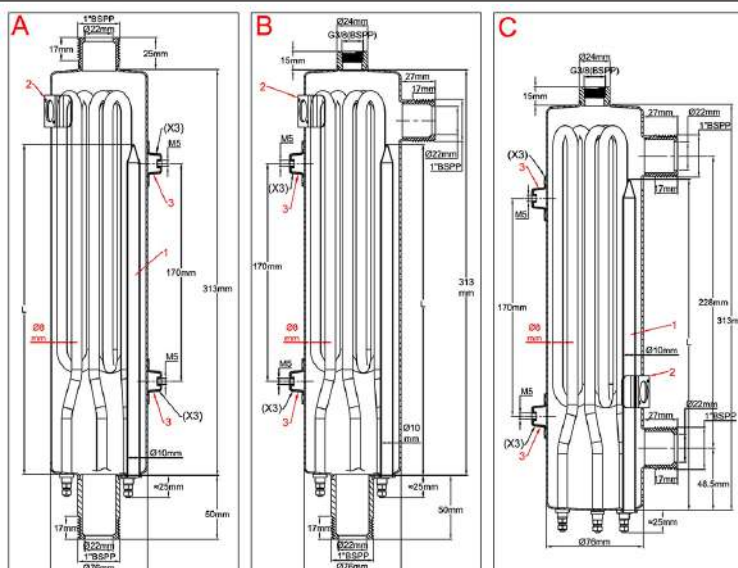

Horizontal (E, F, G)

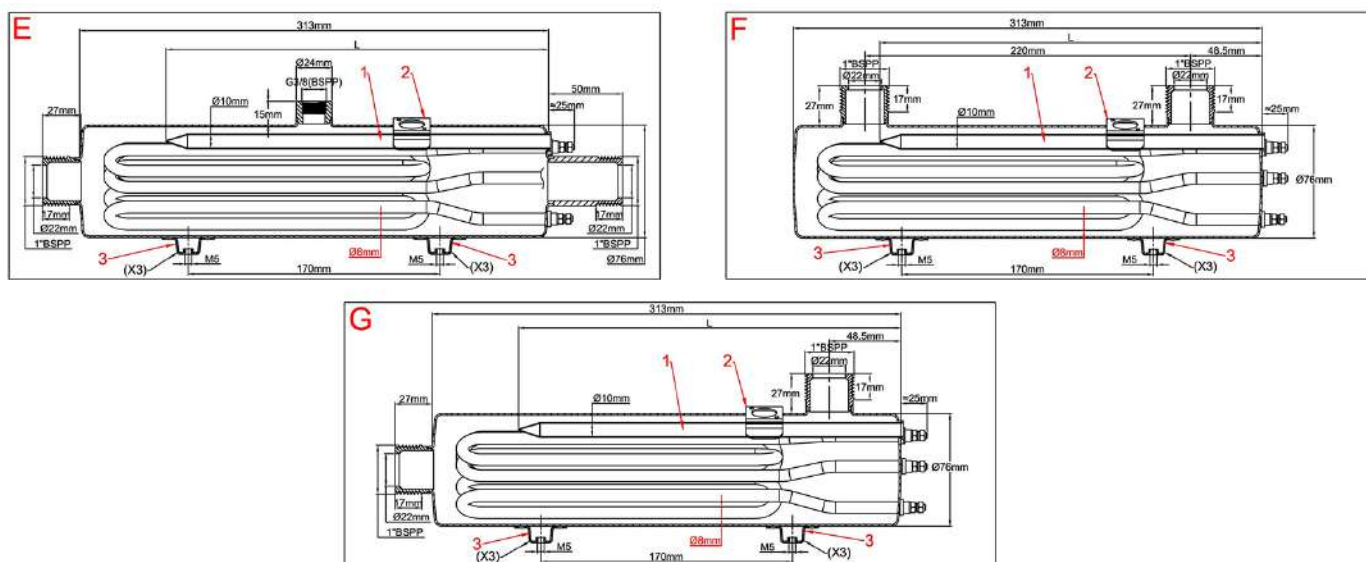



Standard liquids heaters

Diameter of the heaters: 8mm

Tubular heaters material: 316L (Incolloy 800 optional)

Quantity of tubular heaters: 3

Body material: 304L stainless steel (316L optional)

Material fittings: 304L stainless steel (316L optional)

Inlet connection: Male 1" BSPP cylindrical

Outlet diameter: Male 1" BSPP cylindrical

Air vent thread: 3/8" BSPP (on models where it exists)

Thermowell (1): 304L stainless steel dia. 10 × 8.5mm, length 260mm for thermal cut-out (See thermal cut-out sub assembly models at end of this catalog). Copper thermowell is available on request. This thermowell can also be used for a thermostat bulb or a temperature sensor.

Disc thermostat mounting bracket (2): 1 bracket for thermostat with extended cup (see thermostat models at the end of catalog).

Wall mounting brackets (3): 3 × 2 M5 feet, 170mm center line distance, for wall mounting on 3 different sides. M5 brackets that are not used for wall mountings can be used for grounding.

Accessories: see end of catalog

Standard products, 304L stainless steel tanks, hairpin 316L sheathed heaters

References	Style	Surface load (W/cm ²)	Heating elements dia.	Qty of heating elements	Voltage (V)	Power (kW)
9SU231A675G00000	A	10	8	3	230-400	3 × 2.5
9SU231A638G00000	A	5	8	3	230-400	3 × 1.25
9SU231B675G00E00	B	10	8	3	230-400	3 × 2.5
9SU231B638G00E00	B	5	8	3	230-400	3 × 1.25
9SU231C675G00E00	C	10	8	3	230-400	3 × 2.5
9SU231C638G00E00	C	5	8	3	230-400	3 × 1.25
9SU231E675G00E00	E	10	8	3	230-400	3 × 2.5
9SU231E638G00E00	E	5	8	3	230-400	3 × 1.25
9SU231F675G00000	F	10	8	3	230-400	3 × 2.5
9SU231F638G00000	F	5	8	3	230-400	3 × 1.25
9SU231G675G00000	G	10	8	3	230-400	3 × 2.5
9SU231G638G00000	G	5	8	3	230-400	3 × 1.25

Power values are the maximum possible power for a given surface load. It is possible to reduce the power by reducing the surface load.

Because of permanent improvement of our products, drawings, descriptions, features used on these data sheets are for guidance only and can be modified without prior advice



Standard liquids heaters

76mm diameter, length 313mm, helicoil tubular heaters, 1" fittings

Diameter (mm)	Tank length (mm)	Mounting	Tubular heaters Qty	Maximum power	Type
76	313	Vertical or horizontal	3	4.8kW (3 × 1.6kW, 5W/cm ²) 9.6kW (3 × 3.2kW, 10W/cm ²)	9SUB31



Vertical (A, B, C)

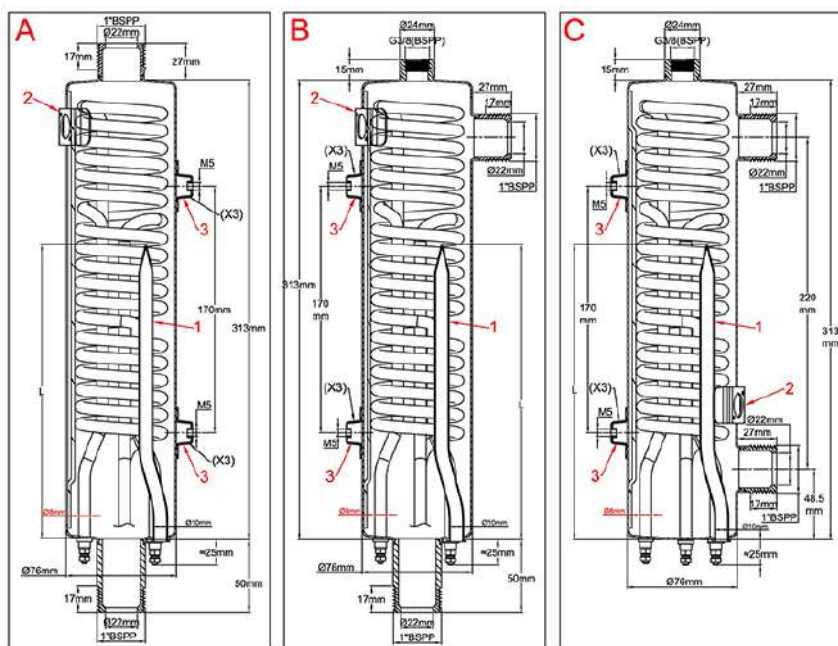

Horizontal (E, F, G)

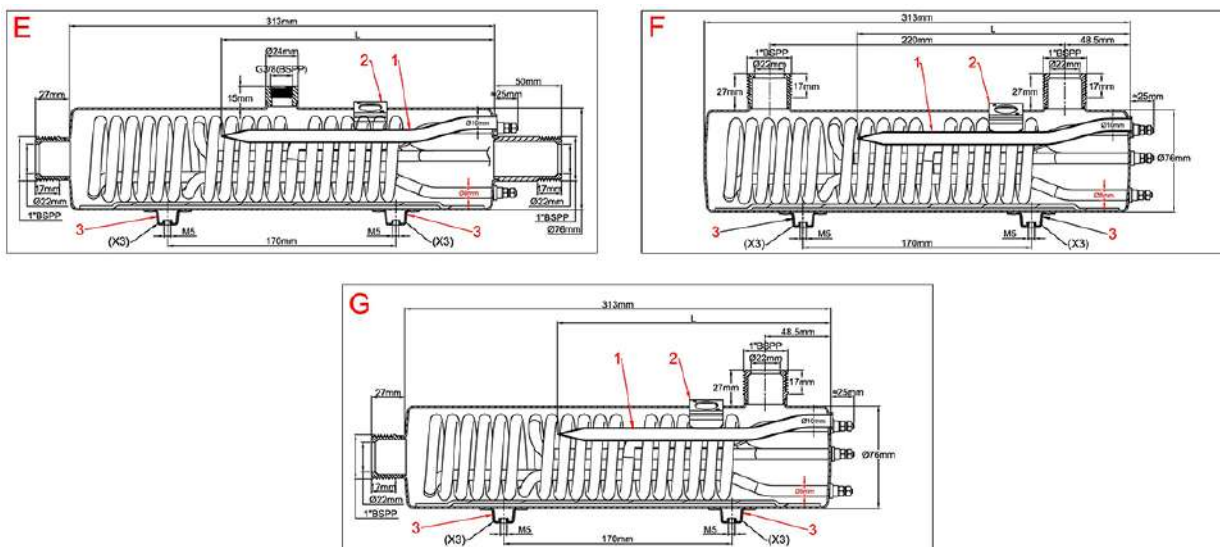

Because of permanent improvement of our products, drawings, descriptions, features used on these data sheets are for guidance only and can be modified without prior advice



Standard liquids heaters

Diameter of the heaters: 8mm

Tubular heaters material: 316L (Incolloy 800 optional)

Quantity of tubular heaters: 3

Body material: 304L stainless steel (316L optional)

Material fittings: 304L stainless steel (316L optional)

Inlet connection: Male 1" BSPP cylindrical

Outlet diameter: Male 1" BSPP cylindrical

Air vent thread: 3/8" BSPP (on models where it exists)

Thermowell (1): 304L stainless steel dia. 10 × 8.5mm, length 260mm for thermal cut-out (See thermal cut-out sub assembly models at end of this catalog). Copper thermowell is available on request. This thermowell can also be used for a thermostat bulb or a temperature sensor.

Disc thermostat mounting bracket (2): 1 bracket for thermostat with extended cup (see thermostat models at the end of catalog).

Wall mounting brackets (3): 3 × 2 M5 feet, 170mm center line distance, for wall mounting on 3 different sides. M5 brackets that are not used for wall mountings can be used for grounding.

Accessories: see end of catalog

Standard products, 304L stainless steel tanks, helicoil 316L sheathed heaters

References	Style	Surface load (W/cm ²)	Heating elements dia.	Qty of heating elements	Voltage (V)	Power (kW)
9SUB31A696G00000	A	10	8	3	230-400	3 × 3.2
9SUB31A648G00000	A	5	8	3	230-400	3 × 1.6
9SUB31B696G00E00	B	10	8	3	230-400	3 × 3.2
9SUB31B648G00E00	B	5	8	3	230-400	3 × 1.6
9SUB31C696G00E00	C	10	8	3	230-400	3 × 3.2
9SUB31C648G00E00	C	5	8	3	230-400	3 × 1.6
9SUB31E696G00E00	E	10	8	3	230-400	3 × 3.2
9SUB31E648G00E00	E	5	8	3	230-400	3 × 1.6
9SUB31F696G00000	F	10	8	3	230-400	3 × 3.2
9SUB31F648G00000	F	5	8	3	230-400	3 × 1.6
9SUB31G696G00000	G	10	8	3	230-400	3 × 3.2
9SUB31G648G00000	G	5	8	3	230-400	3 × 1.6

Power values are the maximum possible power for a given surface load. It is possible to reduce the power by reducing the surface load.

Because of permanent improvement of our products, drawings, descriptions, features used on these data sheets are for guidance only and can be modified without prior advice



Standard liquids heaters

80mm diameter, length 313mm, hairpin tubular heaters, 1 1/4" fittings

Diameter (mm)	Tank length (mm)	Mounting	Tubular heaters Qty	Maximum power	Type
80	313	Vertical or horizontal	3	3.75kW (3 × 1.25kW, 5W/cm ²) 7.5kW (3 × 2.5kW, 10W/cm ²)	9SU331



Vertical (A, B, C)

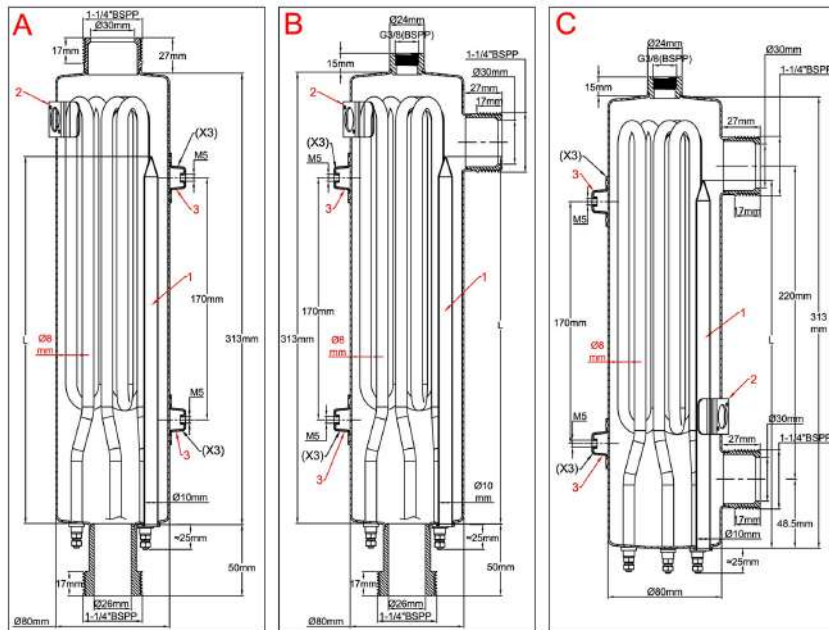

Horizontal (E, F, G)

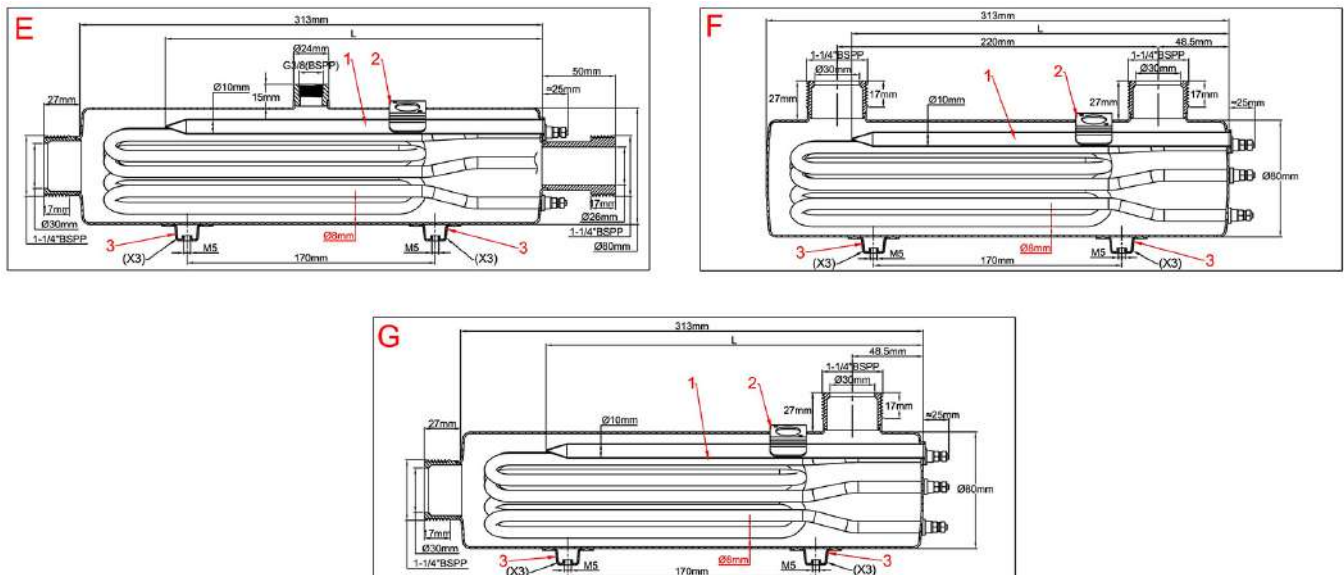

Because of permanent improvement of our products, drawings, descriptions, features used on these data sheets are for guidance only and can be modified without prior advice



Standard liquids heaters

Diameter of the heaters: 8mm

Tubular heaters material: 316L (Incolloy 800 optional)

Quantity of tubular heaters: 3

Body material: 304L stainless steel (316L optional)

Material fittings: 304L stainless steel (316L optional)

Inlet connection: Male 1¼" BSPP cylindrical (1" optional)

Outlet diameter: Male 1¼" BSPP cylindrical (1" optional)

Air vent thread: ⅜" BSPP (on models where it exists)

Thermowell (1): 304L stainless steel dia. 10 × 8.5mm, length 260mm for thermal cut-out (See thermal cut-out sub assembly models at end of this catalog). Copper thermowell is available on request. This thermowell can also be used for a thermostat bulb or a temperature sensor.

Disc thermostat mounting bracket (2): 1 bracket for thermostat with extended cup (see thermostat models at the end of catalog).

Wall mounting brackets (3): 3 × 2 M5 feet, 170mm center line distance, for wall mounting on 3 different sides. M5 brackets that are not used for wall mountings can be used for grounding.

Accessories: see end of catalog

Standard products, 304L stainless steel tanks, hairpin 316L sheathed heaters, 1¼" fittings

References	Style	Surface load (W/cm ²)	Heating elements dia.	Qty of heating elements	Voltage (V)	Power (kW)
9SU331A675G11000	A	10	8	3	230-400	3 × 2.5
9SU331A638G11000	A	5	8	3	230-400	3 × 1.25
9SU331B675G11E00	B	10	8	3	230-400	3 × 2.5
9SU331B638G11E00	B	5	8	3	230-400	3 × 1.25
9SU331C675G11E00	C	10	8	3	230-400	3 × 2.5
9SU331C638G11E00	C	5	8	3	230-400	3 × 1.25
9SU331E675G11E00	E	10	8	3	230-400	3 × 2.5
9SU331E638G11E00	E	5	8	3	230-400	3 × 1.25
9SU331F675G11000	F	10	8	3	230-400	3 × 2.5
9SU331F638G11000	F	5	8	3	230-400	3 × 1.25
9SU331G675G11000	G	10	8	3	230-400	3 × 2.5
9SU331G638G11000	G	5	8	3	230-400	3 × 1.25

Power values are the maximum possible power for a given surface load. It is possible to reduce the power by reducing the surface load.

Because of permanent improvement of our products, drawings, descriptions, features used on these data sheets are for guidance only and can be modified without prior advice



Standard liquids heaters

80mm diameter, length 313mm, helicoil tubular heaters, 1 1/4" fittings

Diameter (mm)	Tank length (mm)	Mounting	Tubular heaters Qty	Maximum power	Type
80	313	Vertical or horizontal	3	10.2kW (3 × 3.4kW 5W/cm ²) 5.1kW (3 × 1,7kW, 10W/cm ²)	9SUC31



Vertical (A, B, C)

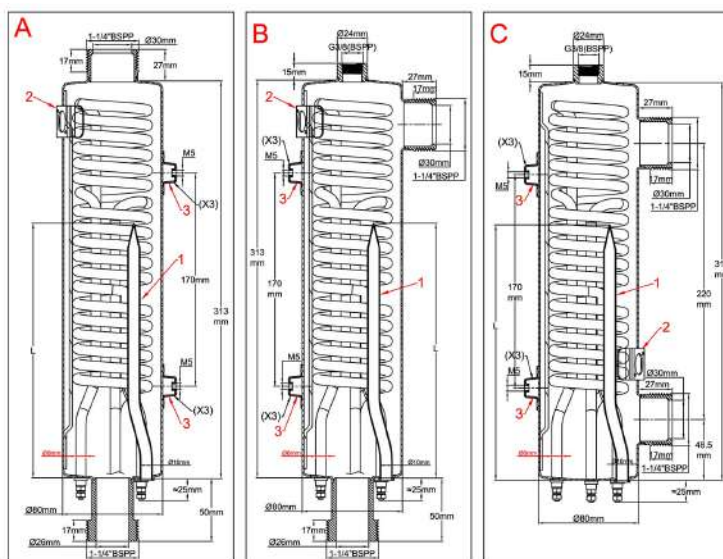

Horizontal (E, F, G)

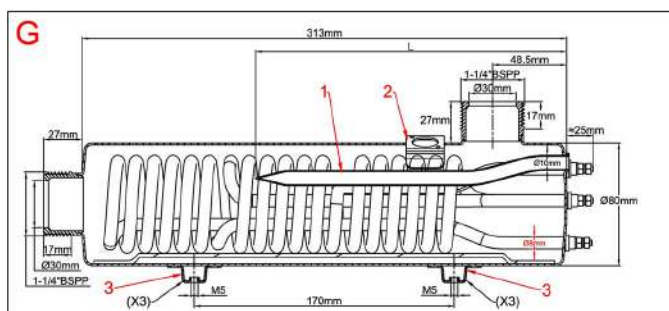
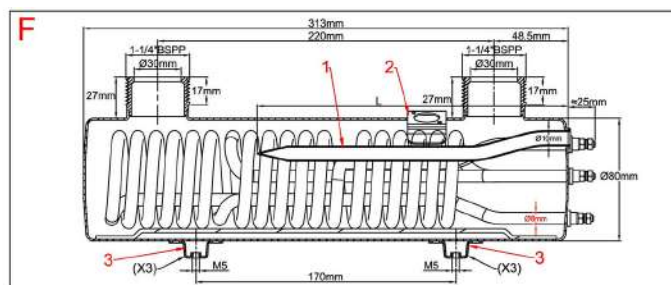
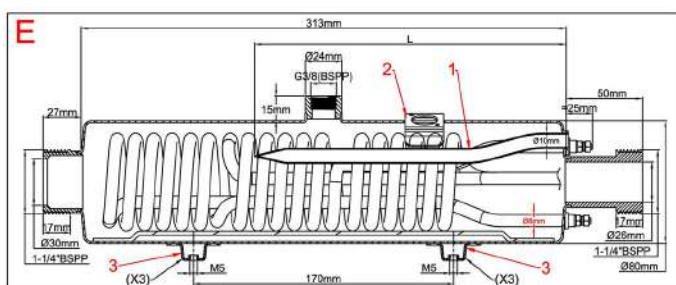

Because of permanent improvement of our products, drawings, descriptions, features used on these data sheets are for guidance only and can be modified without prior advice



Standard liquids heaters

Diameter of the heaters: 8mm

Tubular heaters material: 316L (Incolloy 800 optional)

Quantity of tubular heaters: 3

Body material: 304L stainless steel (316L optional)

Material fittings: 304L stainless steel (316L optional)

Inlet connection: Male 1¼" BSPP cylindrical (1" optional)

Outlet diameter: Male 1¼" BSPP cylindrical (1" optional)

Air vent thread: ⅜" BSPP (on models where it exists)

Thermowell (1): 304L stainless steel dia. 10 × 8.5mm, length 260mm for thermal cut-out (See thermal cut-out sub assembly models at end of this catalog). Copper thermowell is available on request. This thermowell can also be used for a thermostat bulb or a temperature sensor.

Disc thermostat mounting bracket (2): 1 bracket for thermostat with extended cup (see thermostat models at the end of catalog).

Wall mounting brackets (3): 3 × 2 M5 feet, 170mm center line distance, for wall mounting on 3 different sides. M5 brackets that are not used for wall mountings can be used for grounding.

Accessories: see end of catalog

Standard products, 304L stainless steel tanks, helicoil 316L sheathed heaters, 1¼" fittings

References	Style	Surface load (W/cm ²)	Heating elements dia.	Qty of heating elements	Voltage (V)	Power (kW)
9SUC31A6A2G11000	A	10	8	3	230-400	3 × 3.4
9SUC31A651G11000	A	5	8	3	230-400	3 × 1.7
9SUC31B6A2G11E00	B	10	8	3	230-400	3 × 3.4
9SUC31B651G11E00	B	5	8	3	230-400	3 × 1.7
9SUC31C6A2G11E00	C	10	8	3	230-400	3 × 3.4
9SUC31C651G11E00	C	5	8	3	230-400	3 × 1.7
9SUC31E6A2G11E00	E	10	8	3	230-400	3 × 3.4
9SUC31E651G11E00	E	5	8	3	230-400	3 × 1.7
9SUC31F6A2G11000	F	10	8	3	230-400	3 × 3.4
9SUC31F651G11000	F	5	8	3	230-400	3 × 1.7
9SUC31G6A2G11000	G	10	8	3	230-400	3 × 3.4
9SUC31G651G11000	G	5	8	3	230-400	3 × 1.7

Power values are the maximum possible power for a given surface load. It is possible to reduce the power by reducing the surface load.

Because of permanent improvement of our products, drawings, descriptions, features used on these data sheets are for guidance only and can be modified without prior advice



Standard liquids heaters

88mm diameter, length 313mm, hairpin tubular heaters, 1 1/4" fittings

Diameter (mm)	Tank length (mm)	Mounting	Tubular heaters Qty	Maximum power	Type
88	313	Vertical or Horizontal	3	3.75kW (3 × 1.25kW, 5W/cm ²) 7.5kW (3 × 2.5kW, 10W/cm ²)	9SU431



Vertical (A, B, C)

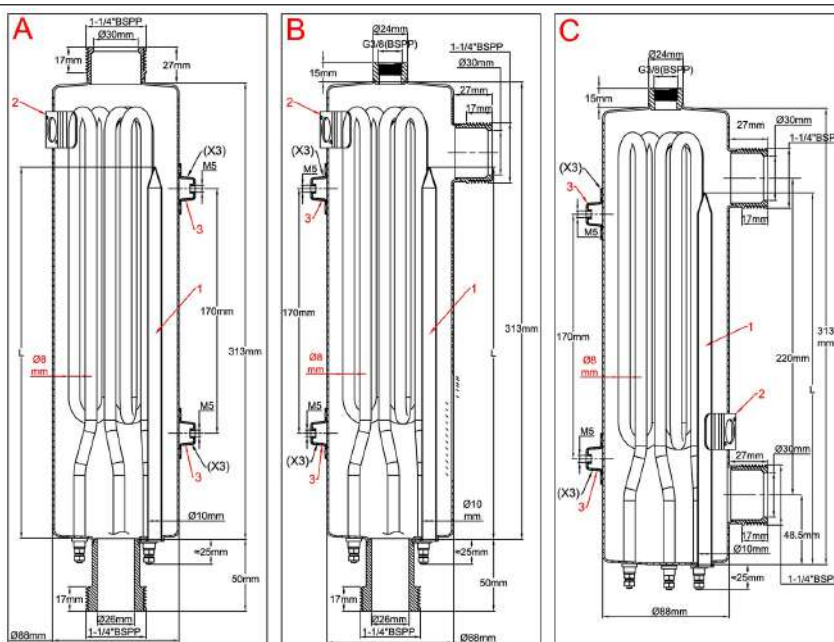

Horizontal (E, F, G)

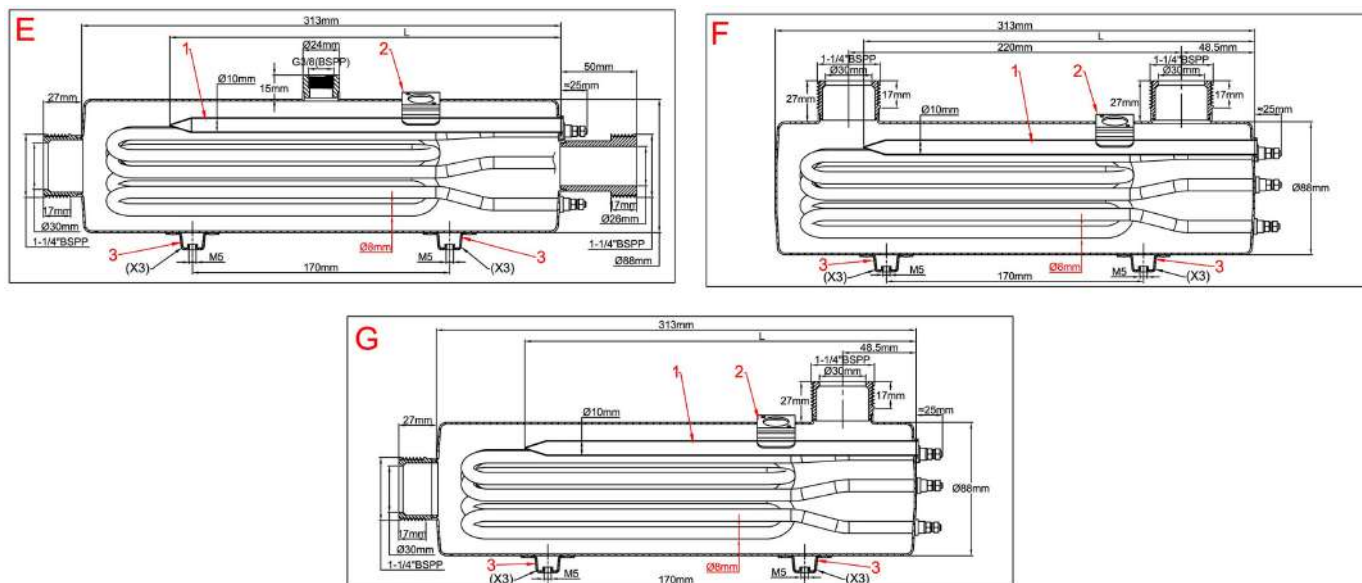



Standard liquids heaters

Diameter of the heaters: 8mm

Tubular heaters material: 316L (Incolloy 800 optional)

Quantity of tubular heaters: 3

Body material: 304L stainless steel (316L optional)

Material fittings: 304L stainless steel (316L optional)

Inlet connection: Male 1¼" BSPP cylindrical (1" optional)

Outlet diameter: Male 1¼" BSPP cylindrical (1" optional)

Air vent thread: ⅜" BSPP (on models where it exists)

Thermowell (1): 304L stainless steel dia. 10 × 8.5mm, length 260mm for thermal cut-out (See thermal cut-out sub assembly models at end of this catalog). Copper thermowell is available on request. This thermowell can also be used for a thermostat bulb or a temperature sensor.

Disc thermostat mounting bracket (2): 1 bracket for thermostat with extended cup (see thermostat models at the end of catalog).

Wall mounting brackets (3): 3 × 2 M5 feet, 170mm center line distance, for wall mounting on 3 different sides. M5 brackets that are not used for wall mountings can be used for grounding.

Accessories: see end of catalog

Standard products, 304L stainless steel tanks, hairpin 316L sheathed heaters, 1¼" fittings

References	Style	Surface load (W/cm ²)	Heating elements dia.	Qty of heating elements	Voltage (V)	Power (kW)
9SU431A675G11000	A	10	8	3	230-400	3 × 2.5
9SU431A638G11000	A	5	8	3	230-400	3 × 1.25
9SU431B675G11E00	B	10	8	3	230-400	3 × 2.5
9SU431B638G11E00	B	5	8	3	230-400	3 × 1.25
9SU431C675G11E00	C	10	8	3	230-400	3 × 2.5
9SU431C638G11E00	C	5	8	3	230-400	3 × 1.25
9SU431E675G11E00	E	10	8	3	230-400	3 × 2.5
9SU431E638G11E00	E	5	8	3	230-400	3 × 1.25
9SU431F675G11000	F	10	8	3	230-400	3 × 2.5
9SU431F638G11000	F	5	8	3	230-400	3 × 1.25
9SU431G675G11000	G	10	8	3	230-400	3 × 2.5
9SU431G638G11000	G	5	8	3	230-400	3 × 1.25

Power values are the maximum possible power for a given surface load. It is possible to reduce the power by reducing the surface load.

Because of permanent improvement of our products, drawings, descriptions, features used on these data sheets are for guidance only and can be modified without prior advice



Standard liquids heaters

88mm diameter, length 313mm, helicoil tubular heaters, 1 1/4" fittings

Diameter (mm)	Tank length (mm)	Mounting	Tubular heaters Qty	Maximum power	Type
88	313	Vertical or horizontal	3	5.7kW (3 × 1.9kW, 5W/cm ²) 11,4kW (3 × 3.8kW, 10W/cm ²)	9SUD31



Vertical (A, B, C)

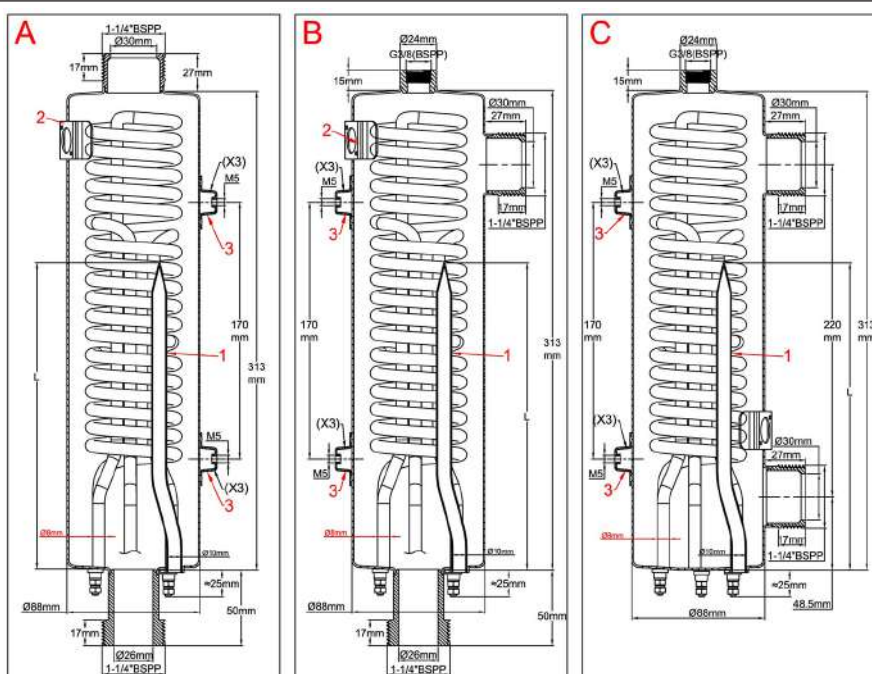

Horizontal (E, F, G)

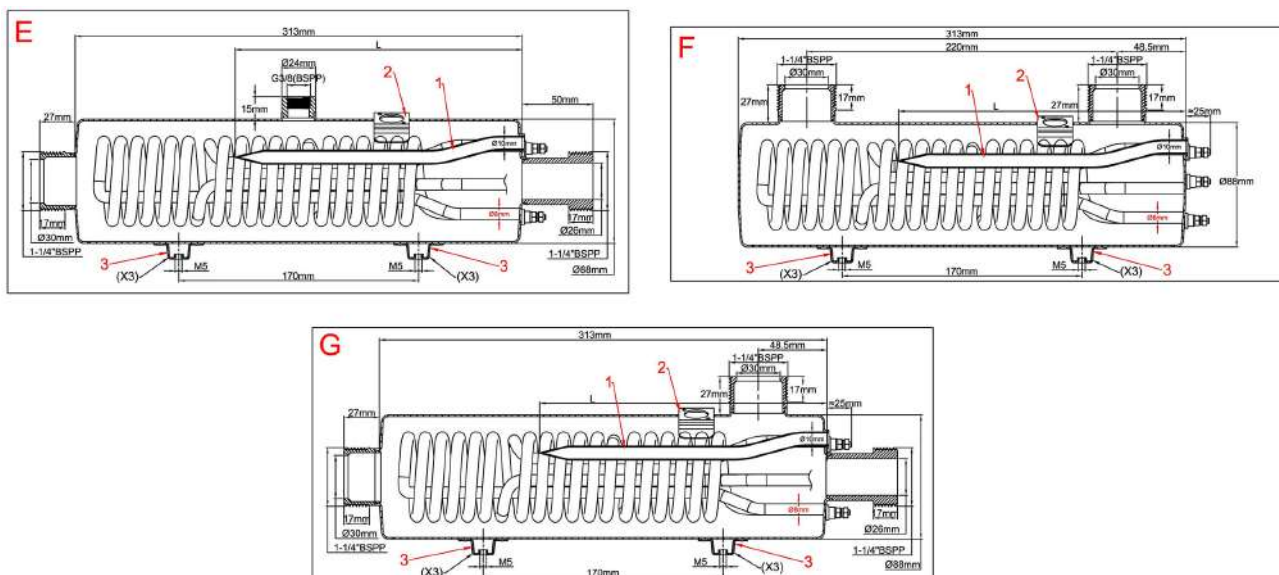



Standard liquids heaters

Diameter of the heaters: 8mm

Tubular heaters material: 316L (Incolloy 800 optional)

Quantity of tubular heaters: 3

Body material: 304L stainless steel (316L optional)

Material fittings: 304L stainless steel (316L optional)

Inlet connection: Male 1¼" BSPP cylindrical (1" optional)

Outlet diameter: Male 1¼" BSPP cylindrical (1" optional)

Air vent thread: ⅜" BSPP (on models where it exists)

Thermowell (1): 304L stainless steel dia. 10 × 8.5mm, length 260mm for thermal cut-out (See thermal cut-out sub assembly models at end of this catalog). Copper thermowell is available on request. This thermowell can also be used for a thermostat bulb or a temperature sensor.

Disc thermostat mounting bracket (2): 1 bracket for thermostat with extended cup (see thermostat models at the end of catalog).

Wall mounting brackets (3): 3 × 2 M5 feet, 170mm center line distance, for wall mounting on 3 different sides. M5 brackets that are not used for wall mountings can be used for grounding.

Accessories: see end of catalog

Standard products, 304L stainless steel tanks, hairpin 316L sheathed heaters, 1¼" fittings

References	Style	Surface load (W/cm ²)	Heating elements dia.	Qty of heating elements	Voltage (V)	Power (kW)
9SUD31A6B4G11000	A	10	8	3	230-400	3 × 3.8
9SUD31A657G11000	A	5	8	3	230-400	3 × 1.9
9SUD31B6B4G11E00	B	10	8	3	230-400	3 × 3.8
9SUD31B657G11E00	B	5	8	3	230-400	3 × 1.9
9SUD31C6B4G11E00	C	10	8	3	230-400	3 × 3.8
9SUD31C657G11E00	C	5	8	3	230-400	3 × 1.9
9SUD31E6B4G11E00	E	10	8	3	230-400	3 × 3.8
9SUD31E657G11E00	E	5	8	3	230-400	3 × 1.9
9SUD31F6B4G11000	F	10	8	3	230-400	3 × 3.8
9SUD31F657G11000	F	5	8	3	230-400	3 × 1.9
9SUD31G6B4G11000	G	10	8	3	230-400	3 × 3.8
9SUD31G657G11000	G	5	8	3	230-400	3 × 1.9

Power values are the maximum possible power for a given surface load. It is possible to reduce the power by reducing the surface load.

Because of permanent improvement of our products, drawings, descriptions, features used on these data sheets are for guidance only and can be modified without prior advice



Standard liquids heaters

100mm diameter, length 313mm, hairpin tubular heaters, 1 1/4" fittings

Diameter (mm)	Tank length (mm)	Mounting	Tubular heaters Qty	Maximum power	Type
100	313	Vertical orl Horizontal	3	4,5kW (3 × 1.5kW, 5W/cm ²) 9kW (3 × 3kW, 10W/cm ²)	9SU531



Vertical (C, D)

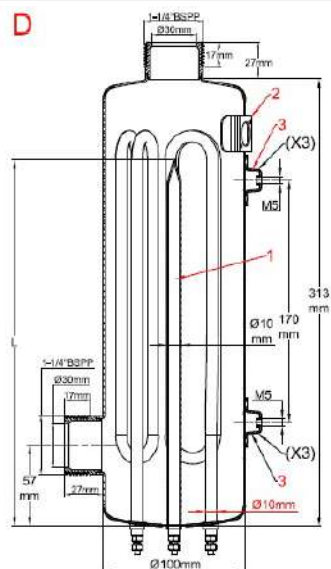
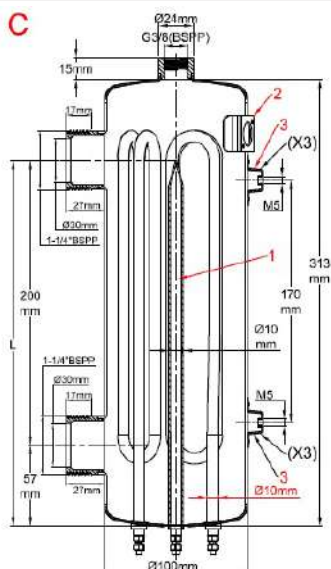

Horizontal (E, F, G)

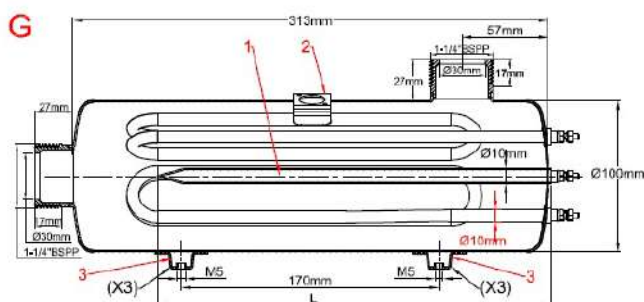
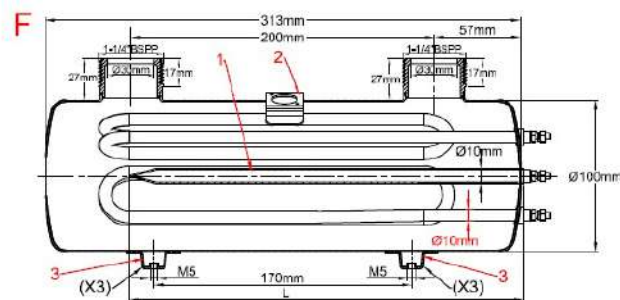
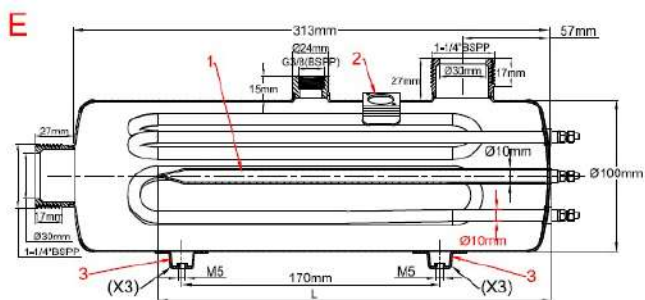



Standard liquids heaters

Diameter of the heaters: 10mm

Tubular heaters material: 316L (Incolloy 800 optional)

Quantity of tubular heaters: 3

Body material: 304L stainless steel (316L optional)

Material fittings: 304L stainless steel (316L optional)

Inlet connection: Male 1¼" BSPP cylindrical (1" optional)

Outlet diameter: Male 1¼" BSPP cylindrical (1" optional)

Air vent thread: ⅜" BSPP (on models where it exists)

Thermowell (1): 304L stainless steel dia. 10 × 8.5mm, length 260mm for thermal cut-out (See thermal cut-out sub assembly models at end of this catalog). Copper thermowell is available on request. This thermowell can also be used for a thermostat bulb or a temperature sensor.

Disc thermostat mounting bracket (2): 1 bracket for thermostat with extended cup (see thermostat models at the end of catalog).

Wall mounting brackets (3): 3 × 2 M5 feet, 170mm center line distance, for wall mounting on 3 different sides. M5 brackets that are not used for wall mountings can be used for grounding.

Accessories: see end of catalog

Standard products, 304L stainless steel tanks, hairpin 316L sheathed heaters, dia 10mm, 1¼" fittings

References	Style	Surface load (W/cm ²)	Heating elements dia.	Qty of heating elements	Voltage (V)	Power (kW)
9SU531C690Y11E00	C	10	10	3	230-400	3 × 3
9SU531C645Y11E00	C	5	10	3	230-400	3 × 1.5
9SU531D690Y11000	D	10	10	3	230-400	3 × 3
9SU531D645Y11000	D	5	10	3	230-400	3 × 1.5
9SU531E690Y11E00	E	10	10	3	230-400	3 × 3
9SU531E645Y11E00	E	5	10	3	230-400	3 × 1.5
9SU531F690Y11000	F	10	10	3	230-400	3 × 3
9SU531F645Y11000	F	5	10	3	230-400	3 × 1.5
9SU531G690Y11000	G	10	10	3	230-400	3 × 3
9SU531G645Y11000	G	5	10	3	230-400	3 × 1.5

Power values are the maximum possible power for a given surface load. It is possible to reduce the power by reducing the surface load.

Because of permanent improvement of our products, drawings, descriptions, features used on these data sheets are for guidance only and can be modified without prior advice



Standard liquids heaters

100mm diameter, length 313mm, helicoil tubular heaters, 1¼" fittings

Diameter (mm)	Tank length (mm)	Mounting	Tubular heaters Qty	Maximum power	Type
100	313	Vertical or horizontal	3	6.45kW (3 × 2.15kW, 5W/cm ²) 12,9kW (3 × 4.3kW, 10W/cm ²)	9SUE31



Vertical (C, D)

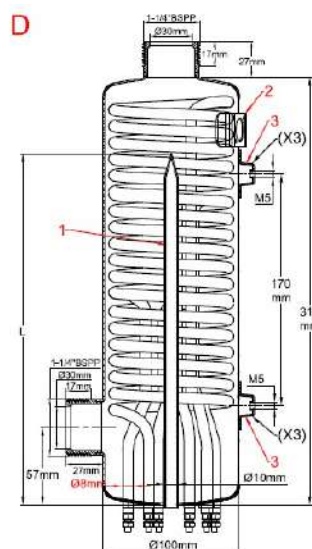
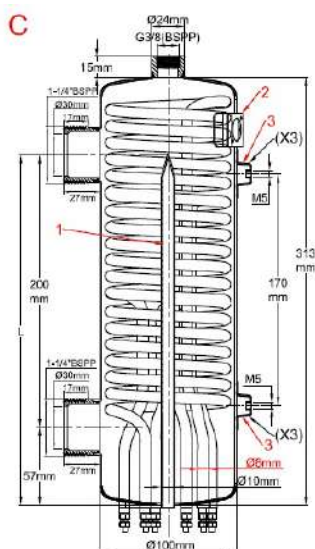

Horizontal (E, F, G)

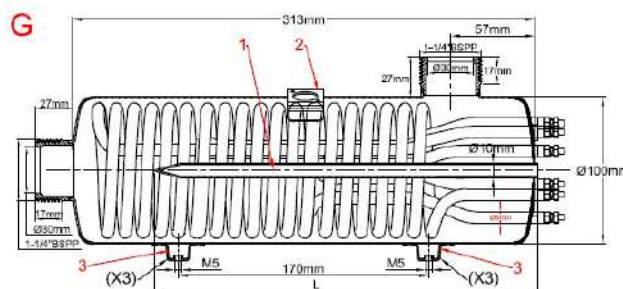
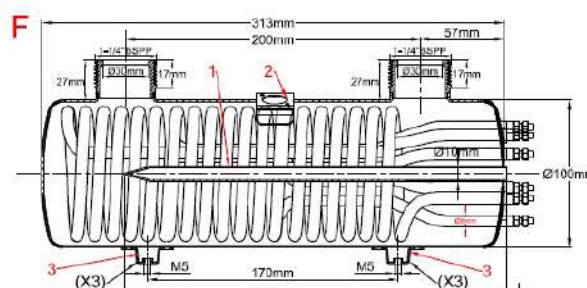
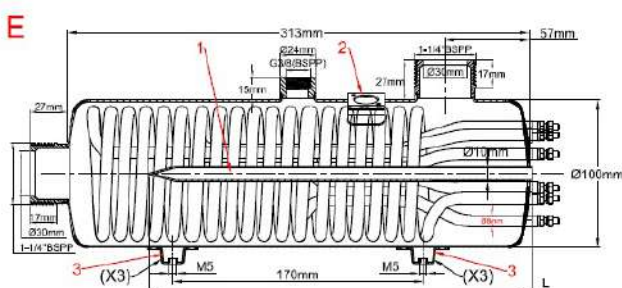



Standard liquids heaters

Diameter of the heaters: 8mm

Tubular heaters material: 316L (Incolloy 800 optional)

Quantity of tubular heaters: 3

Body material: 304L stainless steel (316L optional)

Material fittings: 304L stainless steel (316L optional)

Inlet connection: Male 1¼" BSPP cylindrical (1" optional)

Outlet diameter: Male 1¼" BSPP cylindrical (1" optional)

Air vent thread: ⅜" BSPP (on models where it exists)

Thermowell (1): 304L stainless steel dia. 10 × 8.5mm, length 260mm for thermal cut-out (See thermal cut-out sub assembly models at end of this catalog). Copper thermowell is available on request. This thermowell can also be used for a thermostat bulb or a temperature sensor.

Disc thermostat mounting bracket (2): 1 bracket for thermostat with extended cup (see thermostat models at the end of catalog).

Wall mounting brackets (3): 3 × 2 M5 feet, 170mm center line distance, for wall mounting on 3 different sides. M5 brackets that are not used for wall mountings can be used for grounding.

Accessories: see end of catalog

Standard products, 304L stainless steel tanks, helicoil 316L sheathed heaters, 1¼" fittings

References	Style	Surface load (W/cm ²)	Heating elements dia.	Qty of heating elements	Voltage (V)	Power (kW)
9SUE31C6C9G11E00	C	10	8	3	230-400	3 × 4.3
9SUE31C665G11E00	C	5	8	3	230-400	3 × 2.15
9SUE31D6C9G11000	D	10	8	3	230-400	3 × 4.3
9SUE31D665G11000	D	5	8	3	230-400	3 × 2.15
9SUE31E6C9G11E00	E	10	8	3	230-400	3 × 4.3
9SUE31E665G11E00	E	5	8	3	230-400	3 × 2.15
9SUE31F6C9G11000	F	10	8	3	230-400	3 × 4.3
9SUE31F665G11000	F	5	8	3	230-400	3 × 2.15
9SUE31G6C9G11000	G	10	8	3	230-400	3 × 4.3
9SUE31G665G11000	G	5	8	3	230-400	3 × 2.15

Power values are the maximum possible power for a given surface load. It is possible to reduce the power by reducing the surface load.

Because of permanent improvement of our products, drawings, descriptions, features used on these data sheets are for guidance only and can be modified without prior advice



Standard liquids heaters

125mm diameter, length 313mm, hairpin tubular heaters, 1½" fittings

Diameter (mm)	Tank length (mm)	Mounting	Tubular heaters Qty	Maximum power	Type
125	313	Vertical or Horizontal	3 or 6	9kw (3 × 2kW + 3 × 1kW, 5W/cm ²) 18kw (3 × 4kW + 3 × 2kW 10W/cm ²)	9SU631



Vertical (C, D)

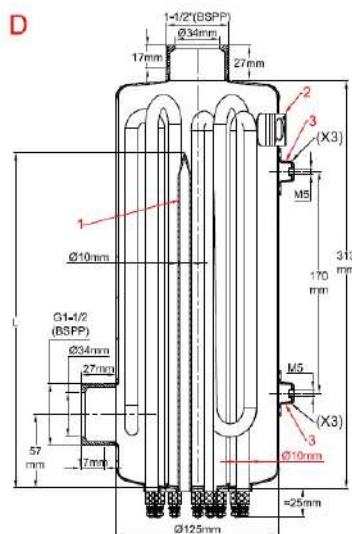
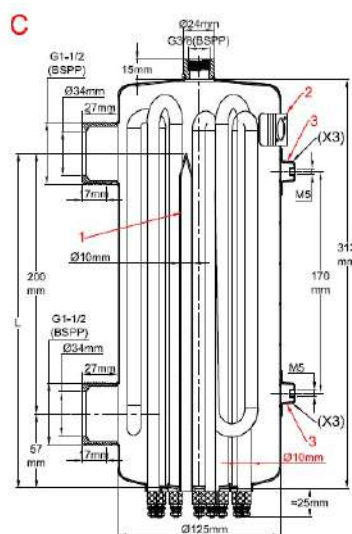

Horizontal (E, F, G)

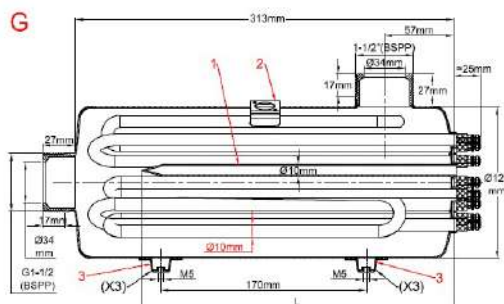
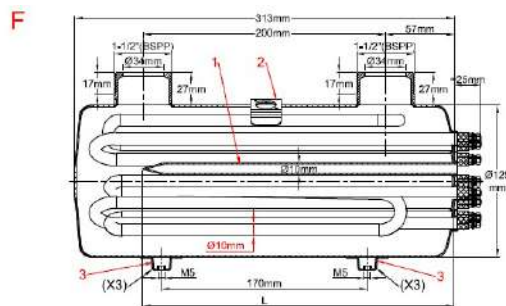
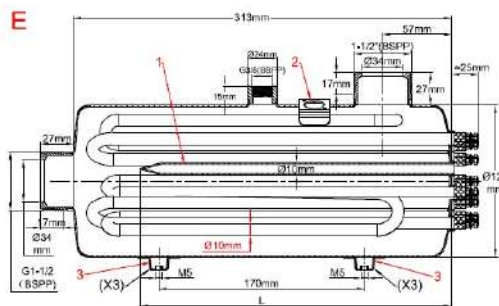



Standard liquids heaters

Diameter of the heaters: 10mm

Tubular heaters material: 316L (Incolloy 800 optional)

Quantity of tubular heaters: 3 or 6. The 6 heaters version allows two stages in three-phase connection.

Body material: 304L stainless steel (316L optional)

Material fittings: 304L stainless steel (316L optional)

Inlet connection: Male 1½" BSPP cylindrical (1¼" optional)

Outlet diameter: Male 1½" BSPP cylindrical (1¼" optional)

Air vent thread: ⅜" BSPP (on models where it exists)

Thermowell (1): 304L stainless steel dia. 10 × 8.5mm, length 260mm for thermal cut-out (See thermal cut-out sub assembly models at end of this catalog). Copper thermowell is available on request. This thermowell can also be used for a thermostat bulb or a temperature sensor.

Disc thermostat mounting bracket (2): 1 bracket for thermostat with extended cup (see thermostat models at the end of catalog).

Wall mounting brackets (3): 3 × 2 M5 feet, 170mm center line distance, for wall mounting on 3 different sides. M5 brackets that are not used for wall mountings can be used for grounding.

Accessories: see end of catalog

Standard products, 304L stainless steel tanks, hairpin 316L sheathed heaters, 1½" fittings

References	Style	Surface load (W/cm ²)	Heating elements dia.	Qty of heating elements	Voltage (V)	Power (kW)
9SU631C6R0Z22E00	C	10	10	6	230-400	3 × 4 + 3 × 2
9SU631C690Z22E00	C	5	10	6	230-400	3 × 2 + 3 × 1
9SU631D6R0Z22000	D	10	10	6	230-400	3 × 4 + 3 × 2
9SU631D690Z22000	D	5	10	6	230-400	3 × 2 + 3 × 1
9SU631E6R0Z22E00	E	10	10	6	230-400	3 × 4 + 3 × 2
9SU631E690Z22E00	E	5	10	6	230-400	3 × 2 + 3 × 1
9SU631F6R0Z22000	F	10	10	6	230-400	3 × 4 + 3 × 2
9SU631F690Z22000	F	5	10	6	230-400	3 × 2 + 3 × 1
9SU631G6R0Z22000	G	10	10	6	230-400	3 × 4 + 3 × 2
9SU631G690Z22000	G	5	10	6	230-400	3 × 2 + 3 × 1

Power values are the maximum possible power for a given surface load. It is possible to reduce the power by reducing the surface load.

Because of permanent improvement of our products, drawings, descriptions, features used on these data sheets are for guidance only and can be modified without prior advice



Standard liquids heaters

140mm diameter, length 313mm, hairpin tubular heaters, 1½" fittings

Diameter (mm)	Tank length (mm)	Mounting	Tubular heaters Qty	Maximum power	Type
140	313	Vertical or Horizontal	3 or 6	9kw (3 × 2kW + 3 × 1kW, 5W/cm ²) 18kw (3 × 4kW + 3 × 2kW 10W/cm ²)	9SU731



Vertical (C, D)

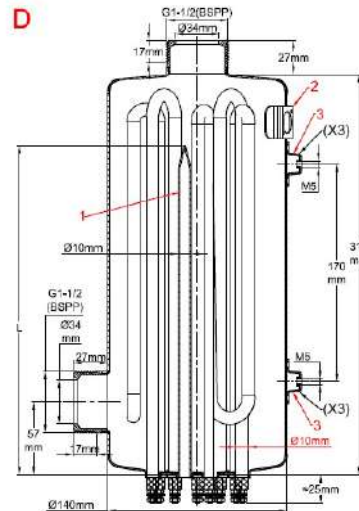
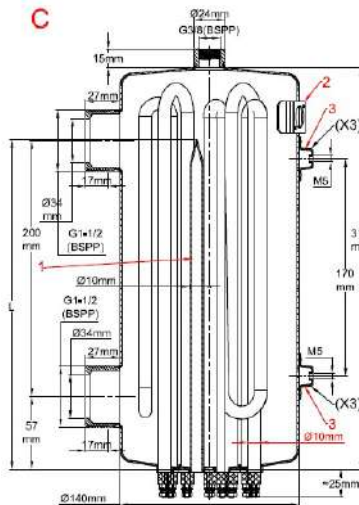

Horizontal (E, F, G)

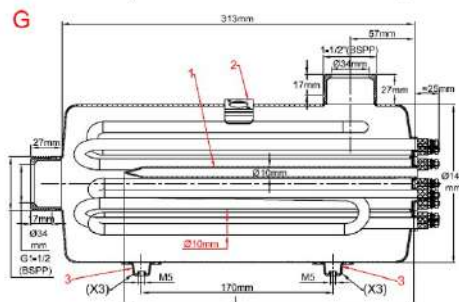
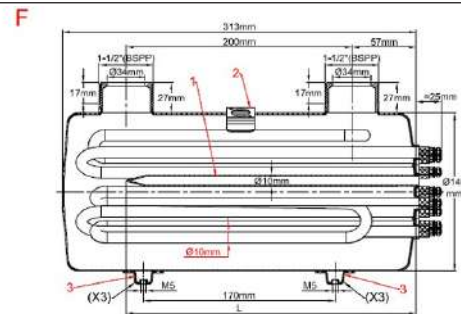

Because of permanent improvement of our products, drawings, descriptions, features used on these data sheets are for guidance only and can be modified without prior advice



Standard liquids heaters

Diameter of the heaters: 10mm

Tubular heaters material: 316L (Incolloy 800 optional)

Quantity of tubular heaters: 3 or 6. The 6 heaters version allows two stages in three-phase connection.

Body material: 304L stainless steel (316L optional)

Material fittings: 304L stainless steel (316L optional)

Inlet connection: Male 1½" BSPP cylindrical (1¼" optional)

Outlet diameter: Male 1½" BSPP cylindrical (1¼" optional)

Centre line inlet outlet: 200mm.

Air vent thread: ⅜" BSPP (on models where it exists)

Thermowell (1): 304L stainless steel dia. 10 × 8.5mm, length 260mm for thermal cut-out (See thermal cut-out sub assembly models at end of this catalog). Copper thermowell is available on request. This thermowell can also be used for a thermostat bulb or a temperature sensor.

Disc thermostat mounting bracket (2): 1 bracket for thermostat with extended cup (see thermostat models at the end of catalog).

Wall mounting brackets (3): 3 × 2 M5 feet, 170mm center line distance, for wall mounting on 3 different sides. M5 brackets that are not used for wall mountings can be used for grounding.

Accessories: see end of catalog

Standard products, 304L stainless steel tanks, hairpin 316L sheathed heaters

References	Style	Surface load (W/cm ²)	Heating elements dia.	Qty of heating elements	Voltage (V)	Power (kW)
9SU731C6R0Z22E00	C	10	10	6	230-400	3 × 4 + 3 × 2
9SU731C690Z22E00	C	5	10	6	230-400	3 × 2 + 3 × 1
9SU731D6R0Z22000	D	10	10	6	230-400	3 × 4 + 3 × 2
9SU731D690Z22000	D	5	10	6	230-400	3 × 2 + 3 × 1
9SU731E6R0Z22E00	E	10	10	6	230-400	3 × 4 + 3 × 2
9SU731E690Z22E00	E	5	10	6	230-400	3 × 2 + 3 × 1
9SU731F6R0Z22000	F	10	10	6	230-400	3 × 4 + 3 × 2
9SU731F690Z22000	F	5	10	6	230-400	3 × 2 + 3 × 1
9SU731G6R0Z22000	G	10	10	6	230-400	3 × 4 + 3 × 2
9SU731G690Z22000	G	5	10	6	230-400	3 × 2 + 3 × 1

Power values are the maximum possible power for a given surface load. It is possible to reduce the power by reducing the surface load.

Because of permanent improvement of our products, drawings, descriptions, features used on these data sheets are for guidance only and can be modified without prior advice



Standard liquids heaters

140mm diameter, length 313mm, hairpin tubular heaters, 1½" fittings, With built-in tubular heat exchanger

Diameter (mm)	Tank length (mm)	Mounting	Tubular heaters Qty	Maximum power	Type
140	313	Vertical or Horizontal	3	4,5kw (3 × 1,5kW, 5W/cm ²) 9kW (3 × 3kW, 10W/cm ²)	9SU831



Vertical (C, D)

Horizontal (F)

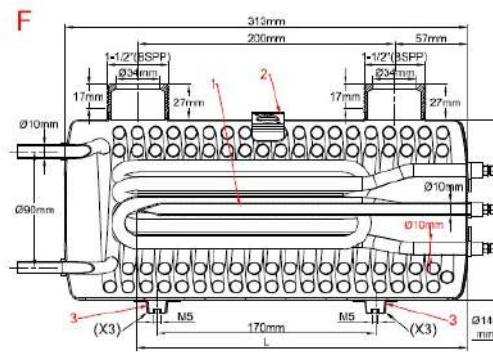
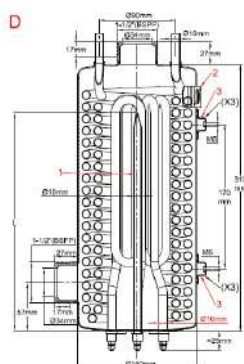
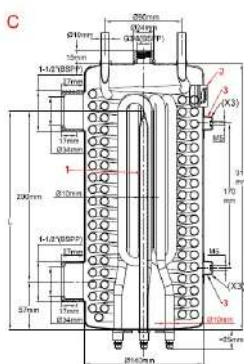

Diameter of the heaters: 10mm

Tubular heaters material: 316L (Incolloy 800 optional)

Quantity of tubular heaters: 3

Body material: 304L stainless steel (316L optional)

Material fittings: 304L stainless steel (316L optional)

Inlet connection: Male 1½" BSPP cylindrical (1¼" optional)

Outlet diameter: Male 1½" BSPP cylindrical (1¼" optional)

Air vent thread: ⅜" BSPP (on models where it exists)

Tubular heat exchanger: dia. 10 × 8.6mm 316L stainless steel tube, heat exchange surface 4000cm²

Thermowell (1): 304L stainless steel dia. 10 × 8.5mm, length 260mm for thermal cut-out (See thermal cut-out sub assembly models at end of this catalog). Copper thermowell is available on request. This thermowell can also be used for a thermostat bulb or a temperature sensor.

Disc thermostat mounting bracket (2): 1 bracket for thermostat with extended cup (see thermostat models at the end of catalog).

Wall mounting brackets (3): 3 × 2 M5 feet, 170mm center line distance, for wall mounting on 3 different sides. M5 brackets that are not used for wall mountings can be used for grounding.

Accessories: see end of catalog

Standard products, 304L stainless steel tanks, hairpin 316L sheathed heaters, SUS 316L tubular heat exchanger, 1½" fittings

References	Style	Surface load (W/cm ²)	Heating elements dia.	Qty of heating elements	Voltage (V)	Power (kW)
9SU831C690Y22E00	C	10	10	3	230-400	3 × 3
9SU831C645Y22E00	C	5	10	3	230-400	3 × 1.5
9SU831D690Y22000	D	10	10	3	230-400	3 × 3
9SU831D645Y22000	D	5	10	3	230-400	3 × 1.5
9SU831F690Y22000	F	10	10	3	230-400	3 × 3
9SU831F645Y22000	F	5	10	3	230-400	3 × 1.5

Power values are the maximum possible power for a given surface load. It is possible to reduce the power by reducing the surface load.



Standard liquids heaters

Examples of insulation and wiring



Because of permanent improvement of our products, drawings, descriptions, features used on these data sheets are for guidance only and can be modified without prior advice



Because of permanent improvement of our products, drawings, descriptions, features used on these data sheets are for guidance only and can be modified without prior advice

Option and accessories



Because of permanent improvement of our products, drawings, descriptions, features used on these data sheets are for guidance only and can be modified without prior advice



Option and accessories

Disc thermostats with condensation protection, types 4RS and 49S

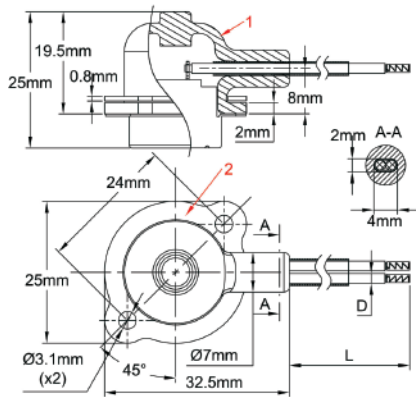

Automatic reset

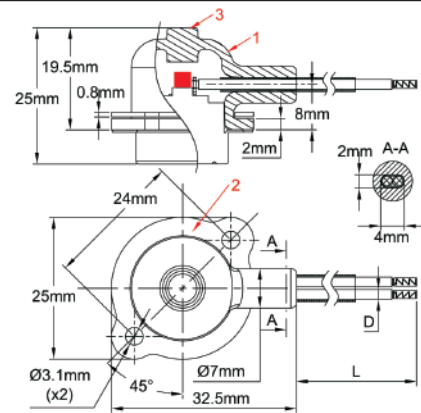

Manual reset

These thermostats were developed for use on the bodies of heaters, in conditions where condensation or drops of water are likely.

The thermostat body is covered with a flexible silicone cap, allowing eventual manual reset without risk of manual contact with live parts. In order to avoid tearing of the cap by handling, it is held in place by a stainless steel flange. The cup of the thermostat is made of stainless steel to avoid the risk of galvanic corrosion between the body of the heater and thermostat, in a humid environment. They are designed to control the liquid temperature, and their use as a dry run safety is not recommended.

When used as a safety device, when they have triggered, it is mandatory to find and repair the failure of the heating circuit before to restart.

Protective cap: black silicon (1)

Electrical rating: 10A 250V (16A on request, contact us)

Action: Contact opens by temperature rise. Available in manual reset (3) or automatic reset by temperature drop. Automatic reset models can be made in an alarm version, with close on temperature rise contact.

Open temperatures: 20 to 150°C according to specifications. The most common versions used in heaters are shown in the table below.

Connecting cable: FEP insulation, two conductors, AWG18, under heat shrink sleeve. (Other dimensions and insulation on request)

Cable length: 500mm standard, other length on request.

Cable end: fitted with crimped cable shoe

Mounting: Stainless steel flange (2), designed to receive two M3 screws, 24mm distance, for fixing on the installed heaters brackets **Mounting on the body of tanks:** it is recommended to use thermo-conductive grease between thermostat cup and tank.

Main references

References	Open temperature (°C)	Close temperature (°C)	Cable length (mm)
4RSFMD055C0B8051	55±3°C	Manual reset	500mm
4RSFMD065D0B8051	65±4°C	Manual reset	500mm
4RSFMD075D0B8051	75±4°C	Manual reset	500mm
4RSFMD085D0B8051	85±4°C	Manual reset	500mm
4RSFMD090D0B8051	90±4°C	Manual reset	500mm
49SFMD040CAB8051	40±3°C	30°C	500mm
49SFMD055DAB8051	55±4°C	45°C	500mm
49SFMD060DAB8051	60±4°C	50°C	500mm
49SFMD070DAB8051	70±4°C	60°C	500mm
49SFMD075DAB8051	75±4°C	55°C	500mm
49SFMD095DAB8051	95±4°C	85°C	500mm

SPNC manual reset high limit, fixed or adjustable set point, fail-safe, 20A.

Type 8L

T85 types		
T150 types		
<p>8L0: M10 mounting, T85 8L3: M10 mounting, T150</p> <p>1: Reset button cap 2: Reset button 3: Capillary sleeving 4: Ground terminal (option)</p>	<p>8L1: 2 × M4 screws mounting, T85 8L4: 2 × M4 screws mounting, T150</p> <p>1: Reset button cap 2: Reset button 3: Capillary sleeving 4: Ground terminal (option) 5: 2xM4 mounting bracket</p>	<p>8L2: 2 × M4 screws mounting and mini adjustment dial, T85 8L5: 2 × M4 screws mounting and mini adjustment dial, T150</p> <p>1: Reset button cap 2: Reset button 3: Capillary sleeving 4: Ground terminal (option) 5: 2xM4 mounting bracket 6: Mini adjustment dial</p>

Technical features

Applications: Protection against the overheating of the heaters due to an abnormal rise of the liquid temperature due to a flow failure. The mounting of the bulbs can be made inside standard dia. 8.5mm pockets, or in an additional thermowell added on request.

Through wall fittings on capillary are also available. The thermostat body can be installed in a protective cover of the heating elements outputs, or remotely in a separate control cabinet. They are resettable after tripping, but prior full audit of the circuit is essential to find the cause of overheating and correct it before restarting.

Because of permanent improvement of our products, drawings, descriptions, features used on these data sheets are for guidance only and can be modified without prior advice



Option and accessories

Because of permanent improvement of our products, drawings, descriptions, features used on these data sheets are for guidance only and can be modified without prior advice

- Housing dimensions:** 24.7 × 33 × 26mm (without terminals and reset). These thermostats exist in two ambient temperature resistance classes: T85 (cheapest) or T150
- Bulb and capillary:** Stainless steel, capillary length 250mm to 1500mm, 100mm long PVC sleeve on capillary. Capillary minimum bending radius 5mm.
- Temperature sensing element:** Liquid filled bulb and capillary.
- Terminals:** 6.35 × 0.8 quick connect terminals (M4 screws also available on request). Terminals can be vertical, horizontal or bended at 45°
- Adjustment:** Fixed setting, sealed or adjustable by mini dial
- Manual reset:** Fail-safe, front access reset button
- Fail-safe contact action by low temperature:** Temperatures under -10°C (14°F) will trigger the manual reset.
- Mounting:** Front bushing with M10 × 1 thread, Maximum recommended tightening torque of M10x1 nut: 1N.m (with 3.5mm thickness nut)
- Rating:** 20(4)A 250V/16 (4)A 400VAC
- Contacts:** SPNC snap action contact
- Max ambient temperature on body:** 85°C (185°F).
- Acceptable degree of pollution for use in 250V:** 3
- Acceptable degree of pollution for use in 400V:** 3

Main references in T85 *** with 750mm capillary* and vertical 6.35mm terminals**

References, M10 mounting	References, 2 × M4 bracket mounting	References, 2 × M4 bracket mounting and mini dial	Calibration temperature (°C/°F)	Bulb diameter (D, mm)	Bulb length (E, mm)	Max temperature on bulb (°C/°F)
8L0070105AG60000	8L1070105AG60000	8L2070105AG60000	70 +0/-8°C (158 +0/-14.4°F)	6	77	105°C/221°F
8L0080105AG60000	8L1080105AG60000	8L2080105AG60000	80 +0/-8°C (176 +0/-14.4°F)	6	77	105°C/221°F
8L0090115AG60000	8L1090115AG60000	8L2090115AG60000	90 +0/-8°C (194 +0/-14.4°F)	6	77	115°C/239°F
8L0100120AG60000	8L1100120AG60000	8L2100120AG60000	100 +0/-8°C (212 +0/-14.4°F)	6	77	120°C/248°F
8L0110135AG60000	8L1110135AG60000	8L2110135AG60000	110 +0/-8°C (230 +0/-14.4°F)	6	77	135°C/275°F
8L0120145AG60000	8L1120145AG60000	8L2120145AG60000	120 +0/-8°C (248 +0/-14.4°F)	6	77	145°C/293°F
8L0130155AG60000	8L1130155AG60000	8L2130155AG60000	130 +0/-8°C (266 +0/-14.4°F)	6	74	155°C/311°F
8L0150175AG60000	8L1150175AG60000	8L2150175AG60000	150 +0/-8°C (302 +0/-14.4°F)	6	74	175°C/347°F
8L0170195AG50000	8L1170195AG50000	8L2170195AG50000	170 +0/-10°C (338 +0/-18°F)	5	70	195°C/383°F
8L0190215AG50000	8L1190215AG50000	8L2190215AG50000	190 +0/-10°C (374 +0/-18°F)	5	70	215°C/419°F
8L0210235AG40000	8L1210235AG40000	8L2210235AG40000	210 +0/-12°C (410 +0/-22°F)	4	65	235°C/455°F
8L0230255AG40000	8L1230255AG40000	8L2230255AG40000	230 +0/-12°C (446 +0/-22°F)	4	65	255°C/490°F

- * Capillary 250mm: replace G by A in the reference; Capillary 1m: replace G by J in the reference; Capillary 1.5m: replace G by O in the reference.
- ** Horizontal 6.35 terminals, replace 0000 by 2000 in the reference; 45° bended 6.35 terminals, replace 0000 by 1000 in the reference. Screw terminals, ask for data sheet.
- *** Ground terminal option: replace 0000 at the end of references by 0G00
- **** T150 types, replace 8L0 by 8L3, 8L1 by 8L4, 8L2 by 8L5.
- Set point temperature up to 500°C can be made, without fail safe action for calibration higher than 400°C. Ask for specific data sheet.

Accessories (Must be ordered separately, shipped assembled on capillary)

	<p style="text-align: right; font-size: small;">66RL41LS30000000</p>	<p>Nickel plated brass capillary fitting for use on liquids up to 130°C (Capillary gasket in NBR)</p>	66RL41LS30000000
	<p style="text-align: right; font-size: small;">66RL41LS20000000</p>	<p>Nickel plated brass capillary fitting for use on liquids up to 230°C (Capillary gasket in FKM)</p>	66RL41LS20000000
	<p style="text-align: right; font-size: small;">66RIMEPM9X1041C7</p>	<p>Stainless steel 304 capillary fitting for use on liquids up to 130°C (Capillary gasket in NBR)</p>	66RIMEPM9X1041C7
	<p style="text-align: right; font-size: small;">66RIMEPM9X1041C8</p>	<p>Stainless steel 304 capillary fitting for use on liquids up to 230°C (Capillary gasket in FKM)</p>	66RIMEPM9X1041C8

3 poles manual reset high limit, fail safe, 25A 250V, 20A 400V, rear mounting Type 82

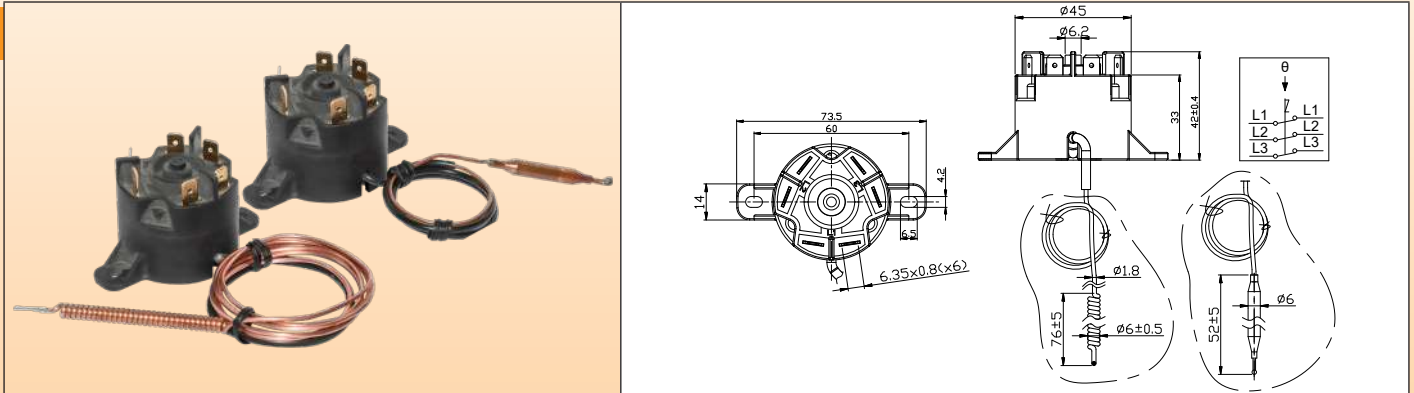

Technical features

Applications: Protection against the overheating of the heaters due to an abnormal rise of the liquid temperature due to a flow failure. The mounting of the bulbs can be made inside standard dia. 8.5mm pockets, or in an additional thermowell added on request. The thermostat body can be installed in a protective cover of the heating elements outputs, or remotely in a separate control cabinet. They are resettable after tripping, but prior full audit of the circuit is essential to find the cause of overheating and correct it before restarting.

Housing dimensions: dia. 45 x 42 mm

Capillary: copper, capillary length 250mm or 900 mm, 150 mm long PVC sleeve on capillary. Capillary minimum bending radius 5 mm.

For technical reasons, we do not recommend to use capillary length longer than 900 mm.

Bulb or helicoid capillary: copper, dia. 6 mm

Temperature sensing element: Liquid-filled thermostatic assembly whose boiling causes tripping of the contact. Therefore, unlike liquid filled systems, these thermostats are little sensitive to atmospheric pressure.

Terminals: 6.35 x 0.8 quick connect terminals

Adjustment: factory fixed setting available between 50°C and 212°C

Mounting: Backside legs, 2 M4 screws, holes distance 60 mm

Manual reset: fail safe action, center button

Rating: 3 × 25A 250VAC, 3 × 20A 400VAC, resistive (6000 cycles), UL, CUL, CE (T85).

Contacts: three poles, open on temperature rise (snap action contact), double break.

Max ambient temperature on head: 150°C (302°F).

Main references with helicoid bulb

Reference	Calibration Temperature (°C/ °F)	Minimum resettable temperature (°C/ °F)	Capillary length (C, mm)	Bulb diameter (D, mm)	Bulb length (L, mm)	Max temperature on bulb (°C/ °F)
820060090AI610F1	60±5°C/140±9°F	20°C/68°F	900	6	50	90°C/ 194°F
820060090AI610F1	60±5°C/140±9°F	20°C/68°F	250	6	50	90°C/ 194°F
820070100AI610F1	70±5°C/158±9°F	30°C/86°F	900	6	50	100°C/ 212°F
820080110AI610F1	80±5°C/176±9°F	40°C/104°F	900	6	50	110°C/ 230°F
820090120AI610F1	90±5°C/194±9°F	50°C/122°F	900	6	50	120°C/ 248°F
820110140AI610F1	110±5°C/230±9°F	70°C/158°F	900	6	50	140°C/ 284°F
820130160AI610F1	130±6°C/266±11°F	90°C/194°F	900	6	60*	160°C/ 320°F
820150180AI610F1	150±7°C/302±13°F	110°C/230°F	900	6	60*	180°C/ 356°F
820170200AI610F1	170±7°C/338±13°F	130°C/266°F	900	6	60*	200°C/ 392°F

- Maximum manual reset set point is 212°C ±12°C. Ask for specific data sheets

Accessories

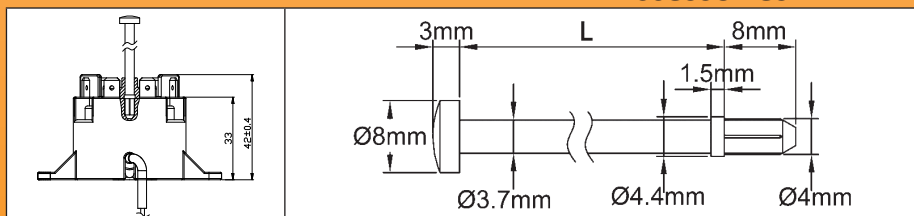

Long distance manual reset rods

L	Reference
114	664CLR114
30	664CLR030

Other length on request



Option and accessories

Wired thermal cut out, 16A250V, for pocket mounting. Type 5MA3-F

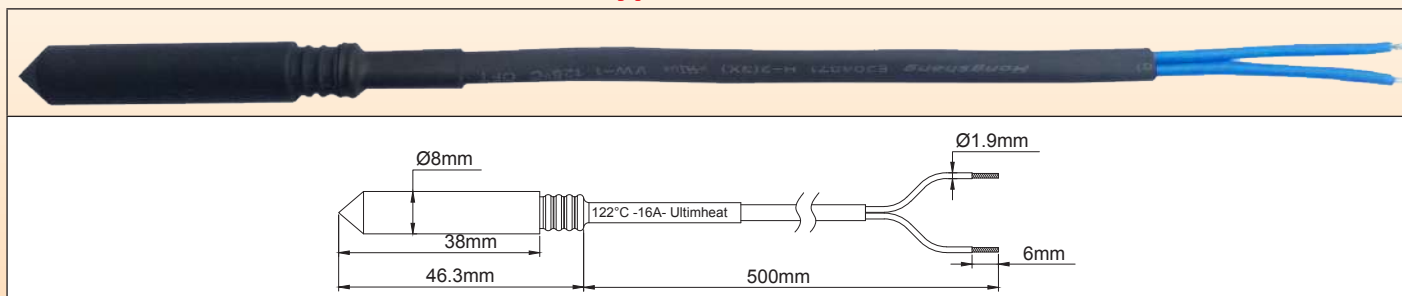

Technical features

Applications: Protection against overheating of liquids heaters when dry run condition occurs. These thermal cut outs are designed to fit the pockets with 8.5 ID mounted in standard in the liquids heaters. It may be possible to replace them when they triggered, but it requires a prior full audit of all components of the heater because the important overheating due to lack of water may have damaged other components.

Fusible pellet: Organic compound.

Mechanism: Movable pellet actuated of a spring released by the fusion of the pellet.

Protection: By electrical insulation silicone boot, dia. 8mm.

Locking in the pocket: By silicone grommet

Nominal current rating: 16A 250V

The nominal current rating is the maximum current the fuse can carry without opening or deteriorate when subjected to a temperature known as the "holding temperature" (Th) for a limited time.

Holding temperature (Th): The fuse must not open or be destroyed when subjected to a temperature equal to Th-6°C for a period of 168 hours under nominal voltage and current.

Rated functioning temperature (Tf): It is the opening temperature of the fuse in a calibration oven, when subjected to a current less than 10mA, when temperature rises at a speed of 0.5 to 1°C/ min. The opening temperature must not be lower than Tf-10°C or above Tf under these conditions. This is the operating temperature Tf which is printed on the fuse and the protective sheath external of the leads.

Maximum temperature (Tm): It is the maximum temperature withstood by the fuse after opening without losing its insulating and mechanical properties.

This feature is critical in liquids heaters application, to determine the right position of TCO to avoid its destruction and re-energization of the electrical circuit by high temperature overshoot.

Insulation voltage between open contacts: ≥500V

Insulation resistance between open contacts: ≥0.2MΩ @ 500V

Lead lengths: 500mm.

Leads: FEP 300V primary insulation, 1mm² gauge (AWG18), in a polyolefin sheath.

In red: Standard temperatures available from stock.

Main references

Reference	Rated functioning temperature °C/ °F (Tf)	Holding temperature °C/ °F (Th)	Maximum temperature °C/ °F (Tm)
5MA3SPF070F18500	73°C/ 163.4°F	45°C/ 113°F	115°C/ 239°F
5MA3SPF077F18500	79°C/ 174.2°F	52°C/ 125.6°F	125°C/ 257°F
5MA3SPF084F18500	85°C/ 185°F	57°C/ 134.6°F	125°C/ 257°F
5MA3SPF091F18500	94°C/ 201.2°F	66°C/ 150.8°F	140°C/ 284°F
5MA3SPF096F18500	99°C/ 210.2°F	71°C/ 159.8°F	140°C/ 284°F
5MA3SPF106F18500	108°C/ 226.4°F	77°C/ 170.6°F	145°C/ 293°F
5MA3SPF109F18500	113°C/ 235.4°F	84°C/ 183.2°F	150°C/ 302°F
5MA3SPF121F18500	122°C/ 251.6°F	94°C/ 201.2°F	175°C/ 347°F
5MA3SPF129F18500	133°C/ 271.4°F	101°C/ 213.8°F	175°C/ 347°F
5MA3SPF139F18500	142°C/ 287.6°F	114°C/ 237.2°F	185°C/ 365°F
5MA3SPF152F18500	157°C/ 314.6°F	127°C/ 260.6°F	195°C/ 383°F
5MA3SPF165F18500	167°C/ 332.6°F	130°C/ 266°F	205°C/ 401°F
5MA3SPF169F18500	172°C/ 341.6°F	145°C/ 293°F	215°C/ 419°F
5MA3SPF182F18500	184°C/ 363.2°F	156°C/ 312.8°F	225°C/ 437°F
5MA3SPF188F18500	192°C/ 377.6°F	164°C/ 327.2°F	245°C/ 473°F
5MA3SPF216F18500	216°C/ 420.8°F	189°C/ 372.2°F	280°C/ 536°F
5MA3SPF227F18500	227°C/ 440.6°F	190°C/ 374°F	295°C/ 563°F
5MA3SPF240F18500	240°C/ 464°F	190°C/ 374°F	305°C/ 581°F

Paddle flow switches, reed switch models, cable connection, Type R1X

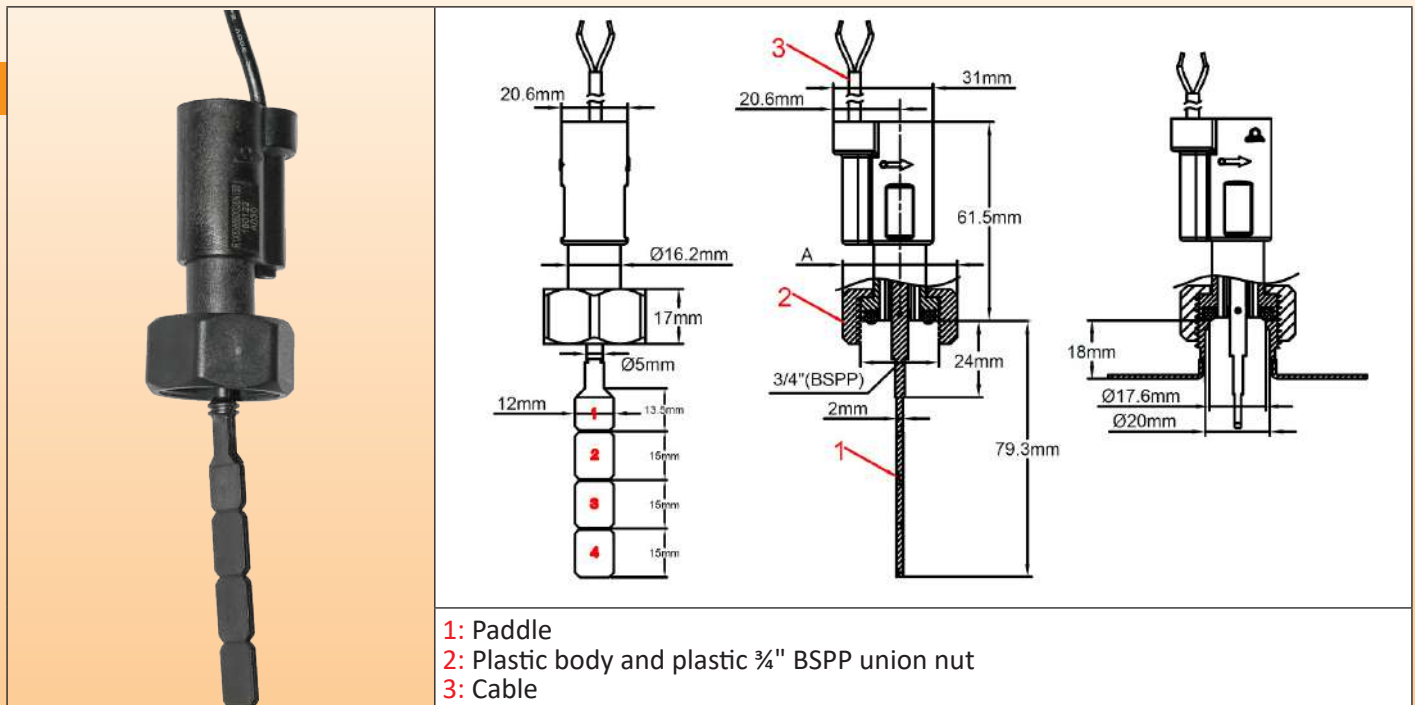

These devices are designed to be mounted on 1", 1 1/4" and 1 1/2" pipes on a 18mm length, 3/4" BSPP male fitting. They are compatible with the applications of liquids heaters of this catalog.

Their low electrical switching rating obliges use them in electronic circuits, or contactor coils. Their function is to allow the energization of the heater when the flow is sufficient, and to stop heating if the flow drops below a specified value. The detection thresholds are variable and are set according to applications and equipment.

Main uses: Recommended mounting position is on horizontal pipes, but can be mounted in any other position, with a small drift in the calibration value.

Functional principle: Balanced magnetic paddle mounted perpendicular to the flow and activating a reed switch through the wall. The return of the paddle is made by magnetic action, without spring. No seal or liquid can pass between the piping system and the electrical contact. Must not be used for water containing magnetic particles or high viscosity liquids, which block the movement of the paddle.

Adjustment: Fixed setting, not adjustable by user

Paddle shaft: **Titanium**, providing an outstanding corrosion resistance, and improved mechanical life.

Main housing material: PPO, fiber glass reinforced for improved pressure and temperature resistance, usable with potable water.

Paddle: PPO, 12mm width

Pipe mounting: Fiber glass reinforced union nut, 3/4" BSPP, mounting on 3/4" BSPP male fitting with gasket.

Recommended torque: 7±1Nm

Gasket: NBR

Electrical rating: Max 1A, Max 70W, Max 250V, resistive load. Use on inductive circuits reduces electrical rating. We recommend to protect the reed switch with contact protection device when used in inductive loads

Electric contact type: Normally open, closes by flow rise

Liquids compatibility: For use with clean water and liquids without magnetic particles and without chemical incompatibility with PPO and titanium

Nominal pressure at 20°C: 1MPa (PN10)

Liquids temperature range: 5 to 100°C (no frost conditions inside the pipe)

Ambient temperature range: 5 to 80°C

Ingress protection: IP65

Calibration tolerances: ±15% (on paddle operating force at end of paddle 1)

Electrical connection: 2 × AWG24 (0.2mm²) cable, PVC insulation, T80°, style UL2464.

Installation instructions: Check carefully the paddle orientation: The arrow on housing must be exactly parallel to the pipe, and in the flow direction.

Accessories: 3/4" stainless steel fitting for pipe welding

Options (MOQ apply): cable with connector or terminals, other cable length, nickel plated 3/4" BSPP union nut, waterproof plastic connection box.



Main references, with 2 meters cable*

Configurations				
	27mm (1"), paddle A1	27mm (1"), paddle B1	36mm (1¼") paddle A1	36mm (1¼") paddle A1+A2
Close on flow rise	22.5 L/min	25 L/min	46 L/min	23 L/min
Open by flow decrease	19 L/min	22.5 L/min	43.5 L/min	20.5 L/min
References	R1X671034G35N100	R1X671234G35N100	R1X671034G35N100	R1X672650G35N100
Configurations				
	36mm (1¼") paddle C2	42mm (1½") paddle A1	42mm (1½") paddle A1+A2	42mm (1½") paddle C2
Close on flow rise	30 L/min	65 L/min	33 L/min	40 L/min
Open by flow decrease	27.5 L/min	63 L/min	31 L/min	37.5 L/min
References	R1X671550G35N100	R1X671034G35N100	R1X672650G35N100	R1X671550G35N100

* Calibration force set at 7 gr measured at end of paddle N°1 or at equivalent length position on other models. (= the middle of the possible adjustment span). Average values for indication only. Exact value must be specified on order. Standard tolerances $\pm 15\%$.

Paddle flow switches, with built-in 16A SPDT relay and connection box, Type RAX

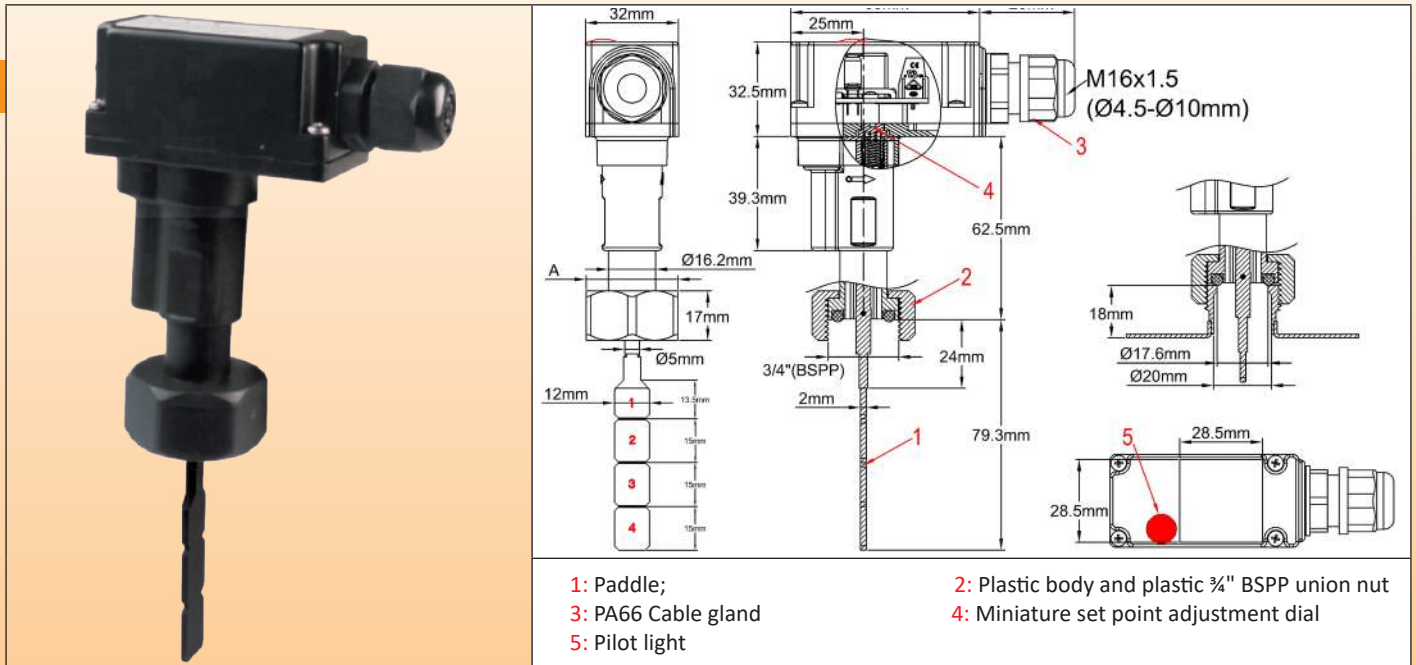

These devices are designed to be mounted on 1", 1¼" and 1½" pipes on a 18mm length, ¾" BSPP male fitting. They are compatible with the applications of liquids heaters of this catalog.

Their built-in 16A 250V power relay allows them to switch directly the power of liquids heaters up to 3500W, 230V. Their function is to allow the energization of the heater when the flow is sufficient, and to stop heating if the flow drops below a specified value. The detection thresholds are variable and are set according to applications and equipment.

Main uses: Recommended mounting position is on horizontal pipes, but can be mounted in any other position, with a small drift in the calibration value.

Functional principle: Balanced magnetic paddle mounted perpendicular to the flow and activating a reed switch through the wall. The return of the paddle is made by magnetic action, without spring. No seal or liquid can pass between the piping system and the electrical contact. Must not be used for water containing magnetic particles or high viscosity liquids, which block the movement of the paddle.

Adjustment: Fixed setting. If needed, it can be slightly modified in the fields by professional installer

Paddle shaft: **Titanium**, providing an outstanding corrosion resistance, and improved mechanical live.

Main housing material: PPO, fiber glass reinforced for improved pressure and temperature resistance, usable with potable water.

Paddle: PPO, 12mm width

Pipe mounting: Fiber glass reinforced union nut, ¾" BSPP, mounting on ¾" BSPP male fitting with gasket.

Recommended torque: 7±1Nm

Gasket: NBR

Electrical rating: Power relay, spdt 16A Resistive, 230V.

Power supply: 230V is standard. Other voltages (115VAC, 24VAC or DC) on request

Pilot light: red (green in option), connected on the power relay contact that closes by flow rise.

Electrical connection: on 5 × 2.5mm² screw connection block. Connectors available on request.

Liquids compatibility: For use with clean water and liquids without magnetic particles and without chemical incompatibility with PPO and titanium

Nominal pressure at 20°C: 1Mpa (PN10)

Liquids temperature range: 5 to 100°C (no frost conditions inside the pipe)

Ambient temperature range: 5 to 80°C

Ingress protection: IP65

Calibration tolerances: ±15% (on paddle operating force at end of paddle 1)

Electrical connection: 2 × AWG24 (0.2mm²) cable, PVC insulation, T80°, style UL2464.

Installation instructions: Check carefully the paddle orientation: The arrow on housing must be exactly parallel to the pipe, and in the flow direction

Accessories: ¾" stainless steel fitting for pipe welding

Options (MOQ apply): nickel plated ¾" BSPP union nut







Flow-switches accessories

		<p>Loose nuts tees for mounting on heaters with 1" BSPP male fittings. Allow to easily add a flow switch in a circuit. Flow switch fitting: 3/4" BSPP male, compatible with RAX series and R1X Nuts: forged brass, captives Body: stainless steel, TIG welded. Bore: 20mm Distance between sealing surfaces (L): 85mm</p> <table border="1"> <tr> <td>Reference in 304L</td> <td>6R1T34208510S</td> </tr> <tr> <td>Reference in 316L</td> <td>6R1T34208510T</td> </tr> </table>	Reference in 304L	6R1T34208510S	Reference in 316L	6R1T34208510T
Reference in 304L	6R1T34208510S					
Reference in 316L	6R1T34208510T					
		<p>Loose nuts tees for mounting on heaters with 1 1/4" BSPP male fittings. Allow to easily add a flow switch in a circuit. Flow switch fitting: 3/4" BSPP male, compatible with RAX series and R1X Nuts: forged brass, captives Body: stainless steel, TIG welded. Bore: 26mm Distance between sealing surfaces (L): 85mm</p> <table border="1"> <tr> <td>Reference in 304L</td> <td>6R1T34268514S</td> </tr> <tr> <td>Reference in 316L</td> <td>6R1T34268514T</td> </tr> </table>	Reference in 304L	6R1T34268514S	Reference in 316L	6R1T34268514T
Reference in 304L	6R1T34268514S					
Reference in 316L	6R1T34268514T					
		<p>Fittings for welding on pipes. Allow to add a flow switch in a circuit after drilling existing pipes. Flow switch thread: 3/4" BSPP male, compatible with RAX series and R1X Material: stainless steel. Hole drill diameter: 21.5mm</p> <table border="1"> <tr> <td>Reference in 304L</td> <td>6R1P3419S</td> </tr> <tr> <td>Reference in 316L</td> <td>6R1P3419T</td> </tr> </table>	Reference in 304L	6R1P3419S	Reference in 316L	6R1P3419T
Reference in 304L	6R1P3419S					
Reference in 316L	6R1P3419T					

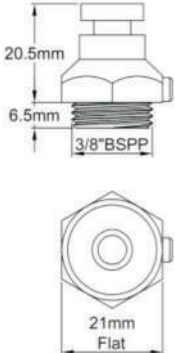

Option and accessories

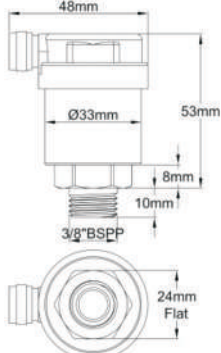
Hydraulic safety options

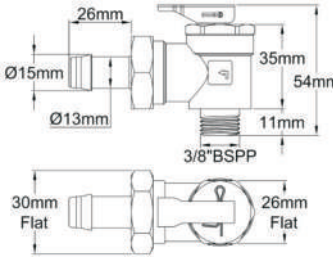
 		<p>Manual air bleeder (air vent)* Fits 3/8" female fittings used in standard heaters. To be assembled with flat fiber gasket or with NBR O-Ring. If it is used at the same time than a relief valve, a second fitting must be added on standard tanks. Material: Brass, nickel plated Thread: 3/8" BSPP</p> <table border="1" data-bbox="808 561 1349 592"> <tr> <td>Reference in nickel plated brass</td> <td>69SUPAM38N</td> </tr> </table>	Reference in nickel plated brass	69SUPAM38N
Reference in nickel plated brass	69SUPAM38N			
 		<p>Automatic air bleeder (air vent)* Fits 3/8" female fittings used in standard heaters. To be assembled with flat fiber gasket. If it is used at the same time than a relief valve, a second fitting must be added on standard tanks. Material: Brass Thread: 3/8" BSPP</p> <table border="1" data-bbox="808 942 1349 973"> <tr> <td>Reference in nickel plated brass</td> <td>69SUPAA38B</td> </tr> </table>	Reference in nickel plated brass	69SUPAA38B
Reference in nickel plated brass	69SUPAA38B			
 		<p>Relief valve* Fits 3/8" female fittings used in standard heaters. To be assembled with flat fiber gasket. If it is used at the same time than an automatic or manual air vent, a second fitting must be added on standard tanks. Calibration: 3Bars Material: Brass Thread: 3/8" BSPP</p> <table border="1" data-bbox="808 1344 1349 1375"> <tr> <td>Reference in nickel plated brass</td> <td>69SUSS0338B</td> </tr> </table>	Reference in nickel plated brass	69SUSS0338B
Reference in nickel plated brass	69SUSS0338B			

* These components are not made by our company. The installation of equivalent products supplied or specified by the customer is possible.

Various options

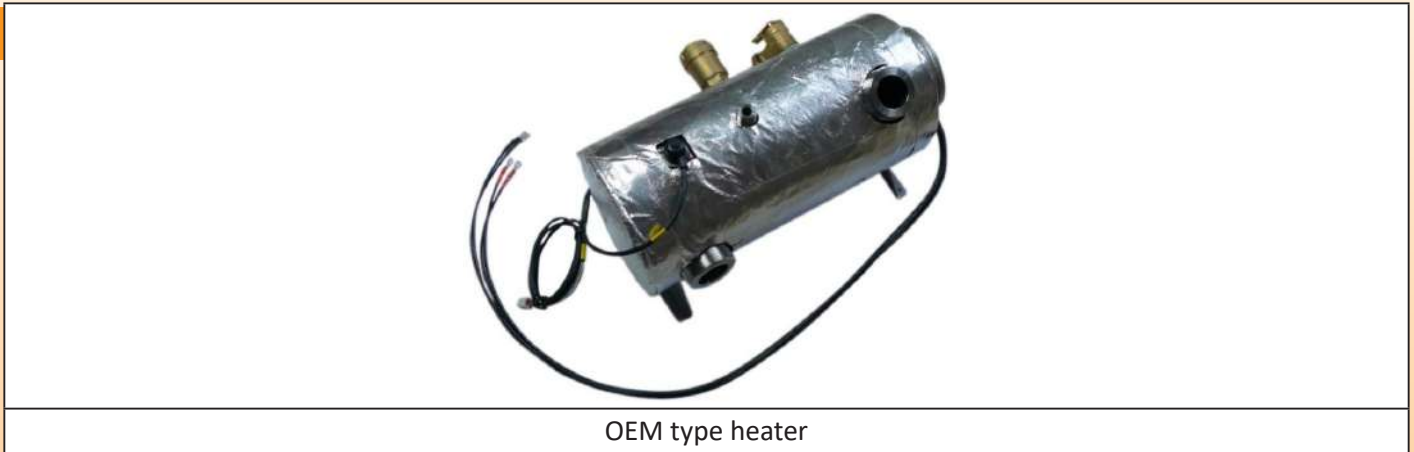

OEM type heater

The options presented on this page concern only standard components. For OEM products, many other opportunities exist for tanks, fittings, mounting systems, types of wiring etc ... We will be glad to answer all requests accompanied by specifications.

		<p>Screw feet These feet are fixed by a screw on the mounting brackets welded on standard tanks. They allow to space tanks from the mounting wall. They come in two basic sizes Material: Stainless steel 304 or 201</p> <table border="1"> <thead> <tr> <th>A</th> <th>B</th> <th>SS</th> <th>References</th> </tr> </thead> <tbody> <tr> <td>70</td> <td>40</td> <td>304</td> <td>69SUSL7040S</td> </tr> <tr> <td>85</td> <td>70</td> <td>304</td> <td>69SUSL8570S</td> </tr> <tr> <td>70</td> <td>40</td> <td>201</td> <td>69SUSL7040V</td> </tr> <tr> <td>85</td> <td>70</td> <td>201</td> <td>69SUSL8570V</td> </tr> </tbody> </table>	A	B	SS	References	70	40	304	69SUSL7040S	85	70	304	69SUSL8570S	70	40	201	69SUSL7040V	85	70	201	69SUSL8570V
A	B	SS	References																			
70	40	304	69SUSL7040S																			
85	70	304	69SUSL8570S																			
70	40	201	69SUSL7040V																			
85	70	201	69SUSL8570V																			
		<p>Foot clamp These feet, which are identical to the series above are fixed by a clamp on the tanks. They allow to space tanks from the mounting wall. They come in two basic sizes. Use appropriate tank clamp diameter. References: see above (the clamp is not provided)</p>																				
		<p>Heating elements wires These sub-assemblies are intended to be mounted on tank heating elements standard screw terminals M4 (3). Silicone cap (1) provides protection against hands contact and condensation. They are equipped with cable end shoe (2) The wire gauge (1mm², 1.5mm², 2.5mm², 4mm² or AWG18, AWG15, AWG14, AWG12), the type of insulation (FEP, XLPE, PVC) and the length and color must be specified when ordering</p>																				

Usual models references



Gauge	Color	Insulation	Length	References
AWG18	black	FEP, 300V, 180°	1m	69SUFRRG18300B100
AWG18	blue	FEP, 300V, 180°	1m	69SUFRRG18300L100
AWG18	yellow/ green	FEP, 300V, 180°	1m	69SUFRRG18300V100

Because of permanent improvement of our products, drawings, descriptions, features used on these data sheets are for guidance only and can be modified without prior advice

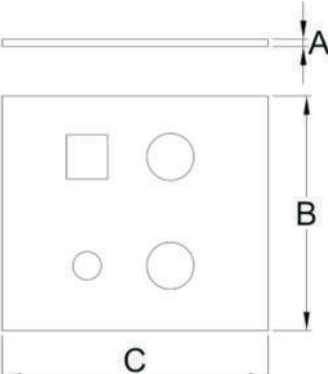

Option and accessories

Various options

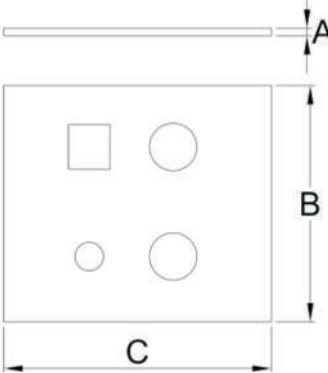
		<p>Foam insulation jackets The NBR-PVC insulating foam comes in standard in 5, 8, 10, 20 or 25mm thickness. The jacket is closed by an adhesive tape. The effectiveness of insulation depends on the chosen thickness. This jacket is usually factory assembled on the heater, but may be provided separately. Contact us for references based on the heater model and the selected thickness.</p>
		<p>Aluminum coated foam insulation jackets The adhesive aluminized sheet is glued over the foam jacket after assembly. The aluminized sheet protects against the absorption of water and improves the resistance to ignition. This assembly is made exclusively at the factory. The lower NBR-PVC insulating foam layer comes in standard in 5, 8, 10, 20 or 25mm. The effectiveness of insulation depends on the chosen thickness. Contact us for references based on the heater model and the chosen thickness.</p>

Because of permanent improvement of our products, drawings, descriptions, features used on these data sheets are for guidance only and can be modified without prior advice



Because of permanent improvement of our products, drawings, descriptions, features used on these data sheets are for guidance only and can be modified without prior advice

Contact us

www.ultimheat.com



ULTIMHEAT

HEAT & CONTROLS



Catalogues collection on
www.ultimheat.com

Electromechanical components & OEM heating sub-assemblies manufacturer

- Mechanical thermostats
- Mechanical safeties single & three poles
- ATEX thermostats & safeties
- Flow through liquid heaters
- Immersion heaters
- Heating elements for air and liquid
- Connection blocks
- Housings for corrosive environments
- Flow switches
- Level switches
- Pressure switches and air switches
- Fusible links and fire detection mechanisms
- Tracing equipment
- **Taylor made solutions**

DEPARTMENT OF **23 5** FLOW THROUGH LIQUID HEATERS FOR INCORPORATION